

28 V / 5 A Rated OVP with Low On-resistance and Integrated TVS

FPF3381

Description

FPF3381UCX is an OVP with integrated ultra-low on-resistance single channel switch. The device contains an N-MOSFET that can operate over an input voltage range of 2.8 V to 23 V and can support a maximum continuous current of 5 A.

When the input voltage exceeds the over-voltage threshold, the internal FET is turned off immediately to prevent damage to the protected downstream components.

The device has integrated ± 110 V surge protection TVS base on IEC61000-4-5 standards.

FPF3381 is available in a small 12-bumps WLCSP package and operate over the free-air temperature range of -40°C to $+85^{\circ}\text{C}$.

Features

- Over-voltage Protection Up to +28 V
- Integrated TVS: ± 110 V for IEC61000-4-5
- Internal Low RDS(on) NMOS Transistors: Typical 15 m Ω
- Programmable Over-voltage Lockout (OVLO)
 - ◆ Externally Adjustable via OVLO Pin
- Active-low Enable Pin (OVLO) for Device
- Super-fast OVLO Response Time: Typical 40 ns
- Over Temperature Protection (Thermal Shutdown)
- Robust ESD Performance
 - ◆ ± 4 kV Human Body Model (HBM)
 - ◆ ± 2 kV Charged Device Model (CDM)
- System Level ESD (IEC61000-4-2)
 - ◆ ± 10 kV Contact Discharge
 - ◆ ± 15 kV Air Gap Discharge

Typical Applications

- Mobile Phones
- PDAs
- GPS



ON Semiconductor®

www.onsemi.com

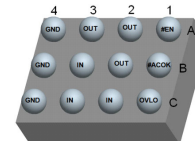

WLCSP-12
CASE 567WP

MARKING DIAGRAM

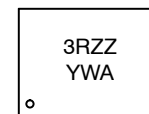

3R = Specific Device Code
 ZZ = Assembly Lot Code
 Y = Year
 W = Work Week
 A = Assembly Location

(Note: Microdot may be in either location)

PIN ASSIGNMENT

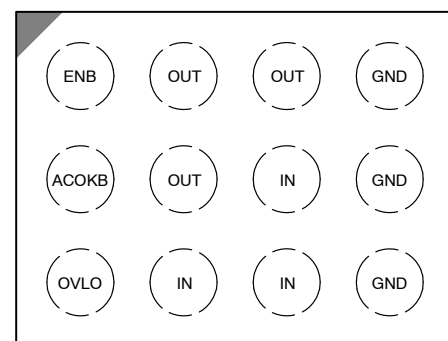

(Top View)

ORDERING INFORMATION

See detailed ordering and shipping information on page 2 of this data sheet.

FPF3381

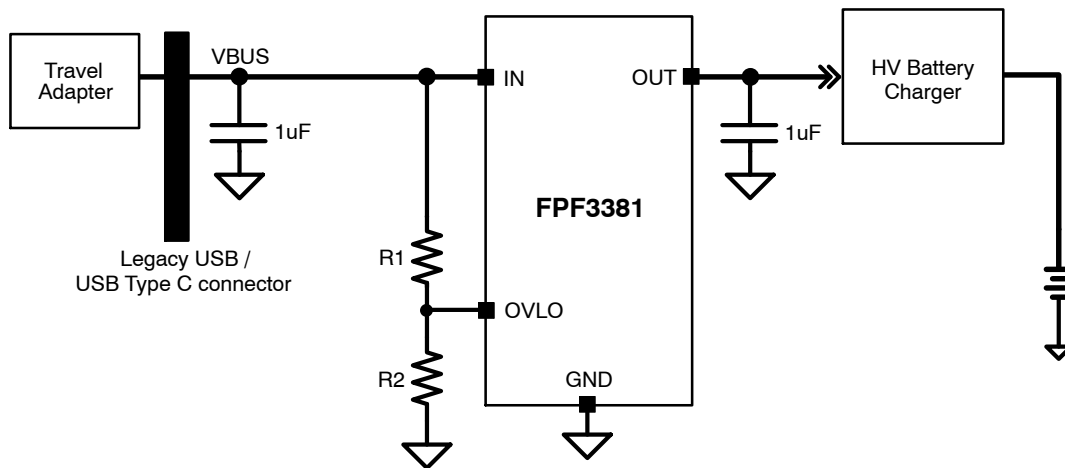

Figure 1. Application Schematic – Adjustable Option

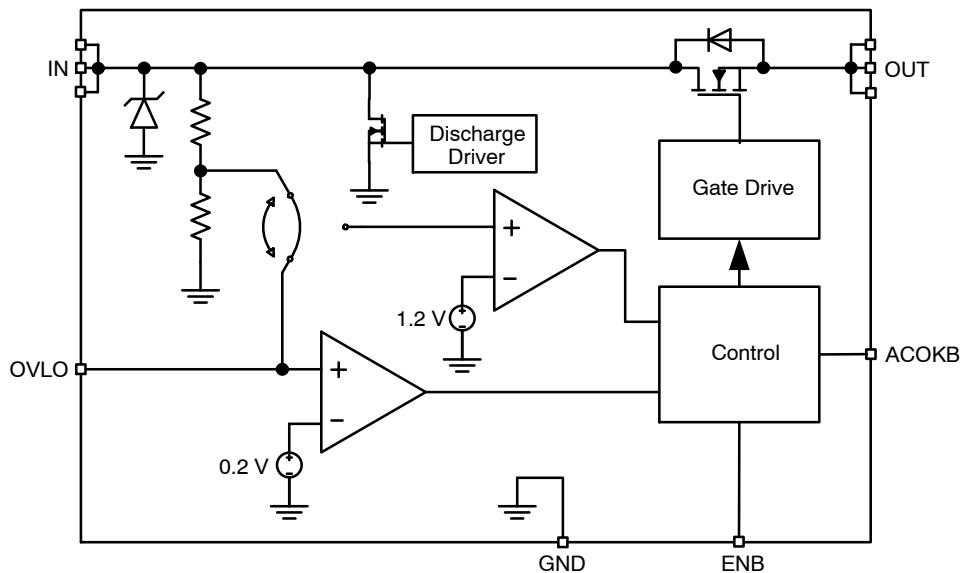

Figure 2. Simplified Block Diagram

PIN FUNCTION DESCRIPTION

| Pin # | Name | Description |
|------------|-------|--|
| B3, C2, C3 | IN | Power Input: Switch Input and Device Supply |
| A2, A3, B2 | OUT | Power Output: Switch Output to Load |
| A1 | ENB | Enable Input: Active Low. 0: Switch enabled. 1: Switch disabled. 1 MΩ Pull-down resistor integrated. |
| B1 | ACOKB | Power Good Acknowledge Output: Open-drain output to indicate Power Good condition |
| C1 | OVLO | OVLO Input: Over Voltage Lockout Adjustment Input |
| A4, B4, C4 | GND | Ground |

ORDERING INFORMATION

| Device | Marking | Package | Shipping† |
|------------|---------|-----------|--------------------|
| FPF3381UCX | 3R | WLCSP-12L | 4000 / Tape & Reel |

†For information on tape and reel specifications, including part orientation and tape sizes, please refer to our Tape and Reel Packaging Specifications Brochure, BRD8011/D.

Table 1. MAXIMUM RATINGS

| Rating | Symbol | Value | Unit |
|---|--------------|----------------------------|--------------|
| Input Voltage Range (Note 1) | V_{in} | -0.3 to +28 | V |
| Output Voltage Range | V_{out} | -0.3 to ($V_{in} + 0.3$) | V |
| Adjustable Input Range | V_{OVLO} | -0.3 to +24 | V |
| Internal FET Continuous Current | I_{OUT} | 0 to 6.25 | A |
| Internal FET Peak Current (pulse width no longer than 100 μ s) | I_{PEAK} | 7 | A |
| Maximum Junction Temperature | $T_{J(max)}$ | 150 | $^{\circ}$ C |
| Storage Temperature Range | T_{STG} | -65 to 150 | $^{\circ}$ C |
| ESD Capability, Human Body Model (Note 2) | ESD_{HBM} | 4 | kV |
| ESD Capability, Charged Device Model (Note 2) | ESD_{CDM} | 2 | |
| IEC 61000-4-2 SYSTEM Level ESD | Contact | 10 | |
| | Air Gap | 15 | |
| Lead Temperature Soldering Reflow (SMD Styles Only), Pb-Free Versions (Note 3) | T_{SLD} | 260 | $^{\circ}$ C |

Stresses exceeding those listed in the Maximum Ratings table may damage the device. If any of these limits are exceeded, device functionality should not be assumed, damage may occur and reliability may be affected.

1. Refer to [ELECTRICAL CHARACTERISTICS](#), [RECOMMENDED OPERATING RANGES](#) and/or [APPLICATION INFORMATION](#) for Safe Operating parameters.
2. This device series incorporates ESD protection and is tested by the following methods:
ESD Human Body Model tested per AEC-Q100-002 (EIA/JESD22-A114)
ESD Charged Device Model tested per AEC-Q100-011 (EIA/JESD22-C101)
Latch-up Current Maximum Rating: ≤ 150 mA per JEDEC standard: JESD78
3. For information, please refer to our Soldering and Mounting Techniques Reference Manual, SOLDERRM/D.

Table 2. THERMAL CHARACTERISTICS

| Rating | Symbol | Value | Unit |
|--|-----------------|-------|----------------|
| Thermal Characteristics, WLCSP-12 (Note 4) Thermal Resistance, Junction-to-Air (Note 5) | $R_{\theta JA}$ | 84.1 | $^{\circ}$ C/W |

4. Refer to [ELECTRICAL CHARACTERISTICS](#), [RECOMMENDED OPERATING RANGES](#) and/or [APPLICATION INFORMATION](#) for Safe Operating parameters.
5. Values based on 2S2P JEDEC std. PCB.

Table 3. RECOMMENDED OPERATING RANGES

| Rating | Symbol | Min | Max | Unit |
|-------------------------|------------|-----|-----|--------------|
| Supply Voltage on VIN | V_{in} | 2.8 | 25 | V |
| I/O pins | V_{OVLO} | 0 | 5.5 | V |
| Output Current (Note 6) | I_{out} | 0 | 5 | A |
| IN Capacitor | C_{in} | 0.1 | | μ F |
| OUT Capacitor | C_{out} | 0.1 | | μ F |
| Ambient Temperature | T_A | -40 | 85 | $^{\circ}$ C |

Functional operation above the stresses listed in the Recommended Operating Ranges is not implied. Extended exposure to stresses beyond the Recommended Operating Ranges limits may affect device reliability.

6. Life time, under maximum current, > 5 years base on Temperature < 85 $^{\circ}$ C and no longer than 12 hours per day.

FPF3381

Table 4. ELECTRICAL CHARACTERISTICS $V_{IN} = 2.8$ to 23 V, $C_{IN} = 0.1$ μ F, $C_{OUT} = 0.1$ μ F, $T_A = -40$ to 85° C; For typical values $V_{IN} = 5.0$ V, $I_{IN} \leq 3$ A, $C_{IN} = 0.1$ μ F, $T_A = 25^\circ$ C, for min/max values $T_A = -40^\circ$ C to 85° C; unless otherwise noted.

| Parameter | Test Conditions | Symbol | Min | Typ | Max | Unit |
|-----------|-----------------|--------|-----|-----|-----|------|
|-----------|-----------------|--------|-----|-----|-----|------|

LEAKAGE AND QUIESCENT CURRENTS

| | | | | | | |
|------------------------------------|--|-------------|------|-----|-----|---------|
| Input Quiescent Current on IN | $V_{IN} = 5$ V, $V_{OVLO} = 0.6$ V, $V_{ENB} = 0$ V | I_Q | | 90 | | μ A |
| | $V_{IN} = 23$ V, $V_{OVLO} = 0.6$ V, $V_{ENB} = 0$ V | | | 150 | | |
| Supply Current during Over Voltage | $V_{IN} = 23$ V, $V_{OVLO} = 1.8$ V, $V_{OUT} = V_{ENB} = 0$ V | I_{IN_Q} | | 150 | | μ A |
| OVLO Input Leakage Current | $V_{OVLO} = V_{OVLO_TH}$ | I_{OVLO} | -100 | | 100 | nA |

OVER VOLTAGE AND UNDER VOLTAGE LOCKOUT, I/O

| | | | | | | |
|---|--|----------------------------------|-------|------|-------|---------|
| Input Clamping Voltage | $I_{IN} = 10$ mA | V_{IN_CLAMP} | | 32 | | V |
| | $I_{IN} = 30$ A (Note 7) | | | 37 | | |
| Under-Voltage Rising Trip Level for VIN | V_{IN} rising, $T_A = -40$ to 85° C | $V_{IN_UV_R}$ | 2.4 | 2.55 | 2.7 | V |
| Under-Voltage Falling Trip Level for VIN | V_{IN} falling, $T_A = -40$ to 85° C | $V_{IN_UV_F}$ | | 2.45 | | V |
| Default Over-Voltage Trip Level | V_{IN} rising, $V_{OVLO} = GND$ | V_{IN_OVLO} | 13.5 | 14.0 | 14.5 | V |
| OVLO Set Threshold | $V_{OVLO} = 1.1$ V to 1.3 V, the voltage of OVLO pin to trigger Over Voltage condition | V_{OVLO_TH} | 1.165 | 1.20 | 1.235 | V |
| OVLO Threshold Hysteresis | | V_{HYS_OVLO} | | 3 | | % |
| OVLO Input Threshold Voltage Voltage Increasing, Logic High Voltage Decreasing, Logic Low | High | V_{IH_OVLO} V_{IL_OVLO} | 0.2 | | 0.1 | V |
| | Low | | | | | |
| ENB Input Threshold Voltage Voltage Increasing, Logic High Voltage Decreasing, Logic Low | High | V_{IH_ENB} V_{IL_ENB} | 0.9 | | 0.3 | V |
| | Low | | | | | |
| Output Low Voltage of ACOKB | $I_{ACOKB} = 1$ mA, Logic Low Asserted | V_{OL} | | | 0.4 | V |
| ACOKB Leakage Current | $V_{I/O} = 3.3$ V, ACOKB De-asserted, $V_{ENB} = 0$ V | I_{ACOKB} | -0.5 | | 0.5 | μ A |

RESISTANCE

| | | | | | | |
|----------------------------|--|----------|--|-----|----|------------|
| On-resistance of Power FET | $V_{IN} = 5$ V, $I_{OUT} = 200$ mA, $T_A = 25^\circ$ C | r_{ON} | | 15 | 20 | m Ω |
| | $V_{IN} = 5$ V to 23 V, $I_{OUT} = 0.1$ A to 5 A (Note 10) | | | | 25 | |
| Pull-down Resistor on ENB | | | | 1 | | M Ω |
| Discharge on IN | $V_{IN} = 5$ V, $V_{ENB} = 1.8$ V | | | 800 | | Ω |

TIMING

| | | | | | | |
|--|---|---------------|--|----|---|---------|
| De-bounce Time of Power FET Turned On | Time from 2.5 V $< V_{IN} < V_{IN_OVLO}$ to $V_{OUT} = 0.1 \times V_{IN}$ | t_{SW_DEB} | | 15 | | ms |
| Soft-Start Time of Power FET Turned On | Time from 2.5 V $< V_{IN} < V_{IN_OVLO}$ to $V_{ACOKB} = 0.2 \times V_{I/O}$ with $V_{I/O} = 1.8$ V and $R_{PU} = 10$ k Ω | t_{SS} | | 30 | | ms |
| Switch Turn-On Rising Time (Note 10) | $V_{IN} = 5$ V, $R_L = 100$ Ω , $C_L = 22$ μ F, V_{OUT} from $0.1 \times V_{IN}$ to $0.9 \times V_{IN}$ | t_R | | 2 | | ms |
| Switch Turn-Off Time (Note 10) | $R_L = 10$ Ω , $C_L = 0$ μ F, time from $V_{IN} > V_{OVLO}$ to $V_{OUT} = 0.9 \times V_{IN}$ (Note 11) | t_{OVP} | | 40 | | ns |
| | time from $V_{ENB} > V_{IH_ENB}$ to $V_{OUT} = 0.9 \times V_{IN}$ | t_{OFF} | | | 2 | μ s |

THERMAL SHUTDOWN

| | | | | | | |
|--|--|----------|---|-----|---|------------|
| Thermal Shutdown Temperature (Note 10) | | T_{SD} | - | 130 | - | $^\circ$ C |
| Thermal Shutdown Hysteresis (Note 10) | | T_{SH} | - | 20 | - | $^\circ$ C |

Product parametric performance is indicated in the Electrical Characteristics for the listed test conditions, unless otherwise noted. Product performance may not be indicated by the Electrical Characteristics if operated under different conditions.

7. The spec is only for surge event. Guaranteed by design and characterization.

8. Performance guaranteed over the indicated operating temperature range by design and/or characterization tested at $T_J = T_A = 25^\circ$ C. Low duty cycle pulse techniques are used during testing to maintain the junction temperature as close to ambient as possible.

9. Refer to the [APPLICATION INFORMATION](#) section.

10. Values based on design and/or characterization.

11. Depends on the capacitance on OVLO pin.

FUNCTION DESCRIPTION

General

FPF3381 is an OVP power switch to protect next stage system which is optimized to lower voltage working condition. The device includes ultra-low on-resistance power FET (15 mΩ) and internal TVS for surge event protection base on IEC61000-4-5. The super-fast OVP response time is only 40 ns for default OVP condition.

Power MOSFET

The FPF3381 integrates an N-type MOSFET with 15 mΩ resistance. The power FET can work under 2.8 V ~ 25 V and up to 5 A DC current capability.

Power Supply

The FPF3381 is supplied by IN.

IN will be firstly supplied by OUT when the device is working under USB On-The-Go (OTG) condition.

Enable Control

FPF3381 has an active low enable pin ENB. When ENB pin is connected to a high level, the internal FET will be turned off. When ENB pin is connected to low level, the FET will be turned on as long as V_{IN} is not higher than Over-Voltage threshold.

Under Voltage Lockout

FPF3381 power switch will be turned off when the voltage on IN is lower than the UVLO threshold V_{IN_UV_F}.

Whenever VIN voltage ramps up to higher than V_{IN_UV_R}, the power FET will be turned on automatically after t_{DEB} de-bounce time if there is no OV or OT condition.

Over Voltage Lockout

The power FET will be turned off whenever IN voltage higher than V_{IN_OVLO}. The value of V_{IN_OVLO} can be set by external resistor ladder or just be default value V_{IN_OVLO}.

When V_{OVLO} is smaller than V_{IL_OVLO}, V_{OVLO} will be decided by default value. When V_{OVLO} is larger than V_{IH_OVLO}, the power switch will be turned off once V_{OVLO} > V_{OVLO_TH}. The external resistor ladder can be decided according to the following equation:

$$V_{IN_OVLO} = V_{OVLO_TH} \times (1 + R1/R2) \quad (\text{eq. 1})$$

where R1 and R2 are the resistors in Figure 1.

Power OK indicator

FPF3381 has an Open-Drain output ACOKB. By implement connection to external supply through a resistor, ACOKB can indicate the status on IN (or VBUS). When VIN is between V_{IN_UV_R} and V_{IN_OVLO} more than 30 ms, ACOKB will be pulled down to ground. If the input voltage is out of this range, ACOKB will present as a floating node and the voltage will be pulled high by external power supply.

Thermal Shutdown

When the device is in the switch mode, to protect the device from over temperature, the power switch will be turned off when the junction temperature exceeds T_{SD}. The switch will be turned on again when temperature drop below T_{SD} - T_{SH}.

APPLICATIONS INFORMATION

Input Decoupling (C_{in})

A ceramic or tantalum at least 0.1 μF capacitor is recommended and should be connected close to the FPF338x package. Higher capacitance and lower ESR will improve the overall line and load transient response.

Output Decoupling (C_{out})

The FPF3381 is a stable component and does not require a minimum Equivalent Series Resistance (ESR) for the output capacitor. The minimum output decoupling value is 0.1 μF and can be augmented to fulfill stringent load transient requirements.

Thermal Considerations

As power in the FPF3381 increases, it might become necessary to provide some thermal relief. The maximum power dissipation supported by the device is dependent upon board design and layout. Mounting pad configuration on the PCB, the board material, and the ambient temperature affect the rate of junction temperature rise for the part. When the FPF3381 has good thermal conductivity through

the PCB, the junction temperature will be relatively low with high power applications. The maximum dissipation the FPF3381 can handle is given by:

$$P_{D(MAX)} = \frac{[T_{J(MAX)} - T_A]}{R_{\theta JA}} \quad (\text{eq. 2})$$

Since T_J is not recommended to exceed 125°C, then the FPF3381 soldered on 645 mm², 1 oz copper area, and the ambient temperature (T_A) is 25°C. The power dissipated by the FPF3381 can be calculated from the following equations:

$$P_D \approx V_{in} \cdot (I_Q @ I_{out}) + I_{out}^2 \cdot r_{ON} \quad (\text{eq. 3})$$

Hints

V_{in} and V_{out} printed circuit board traces should be as wide as possible. Place external components, especially the input capacitor and TVS, as close as possible to the FPF3381, and make traces as short as possible.



WLCSP12 1.828x1.288x0.574
CASE 567WP
ISSUE O

DATE 25 JUN 2018

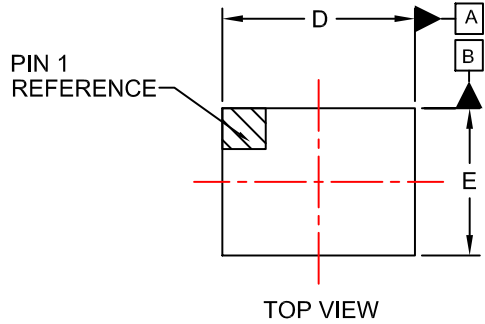

NOTES:

1. DIMENSIONING AND TOLERANCING PER ASME Y14.5M, 2009.
2. CONTROLLING DIMENSION: MILLIMETERS
3. DATUM C APPLIES TO THE SPHERICAL CROWN OF THE SOLDER BALLS

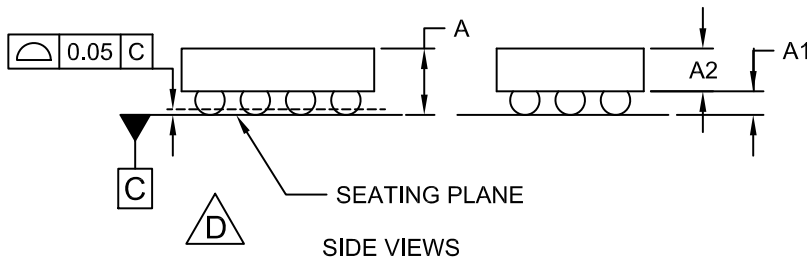

| DIM | MILLIMETERS | | |
|-----|-------------|-------|-------|
| | MIN. | NOM. | MAX. |
| A | 0.536 | 0.574 | 0.612 |
| A1 | 0.176 | 0.196 | 0.216 |
| A2 | 0.360 | 0.378 | 0.396 |
| b | 0.240 | 0.260 | 0.280 |
| D | 1.798 | 1.828 | 1.858 |
| E | 1.258 | 1.288 | 1.318 |
| e | 0.40 BSC | | |
| x | 0.299 | 0.314 | 0.329 |
| y | 0.229 | 0.244 | 0.259 |

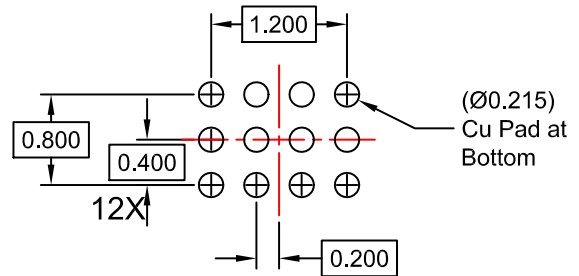
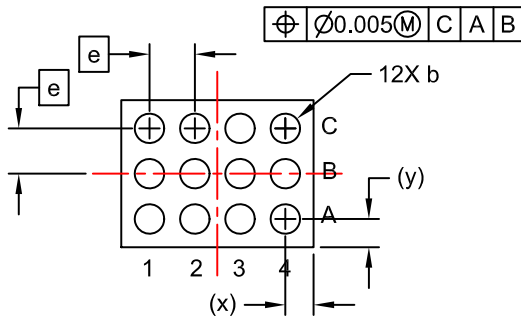

| | | |
|-------------------------|----------------------------------|--|
| DOCUMENT NUMBER: | 98AON93136G | Electronic versions are uncontrolled except when accessed directly from the Document Repository. Printed versions are uncontrolled except when stamped "CONTROLLED COPY" in red. |
| DESCRIPTION: | WLCSP12 1.828x1.288x0.574 | PAGE 1 OF 1 |

ON Semiconductor and are trademarks of Semiconductor Components Industries, LLC dba ON Semiconductor or its subsidiaries in the United States and/or other countries. ON Semiconductor reserves the right to make changes without further notice to any products herein. ON Semiconductor makes no warranty, representation or guarantee regarding the suitability of its products for any particular purpose, nor does ON Semiconductor assume any liability arising out of the application or use of any product or circuit, and specifically disclaims any and all liability, including without limitation special, consequential or incidental damages. ON Semiconductor does not convey any license under its patent rights nor the rights of others.

ON Semiconductor and  are trademarks of Semiconductor Components Industries, LLC dba ON Semiconductor or its subsidiaries in the United States and/or other countries. ON Semiconductor owns the rights to a number of patents, trademarks, copyrights, trade secrets, and other intellectual property. A listing of ON Semiconductor's product/patent coverage may be accessed at www.onsemi.com/site/pdf/Patent-Marking.pdf. ON Semiconductor reserves the right to make changes without further notice to any products herein. ON Semiconductor makes no warranty, representation or guarantee regarding the suitability of its products for any particular purpose, nor does ON Semiconductor assume any liability arising out of the application or use of any product or circuit, and specifically disclaims any and all liability, including without limitation special, consequential or incidental damages. Buyer is responsible for its products and applications using ON Semiconductor products, including compliance with all laws, regulations and safety requirements or standards, regardless of any support or applications information provided by ON Semiconductor. "Typical" parameters which may be provided in ON Semiconductor data sheets and/or specifications can and do vary in different applications and actual performance may vary over time. All operating parameters, including "Typicals" must be validated for each customer application by customer's technical experts. ON Semiconductor does not convey any license under its patent rights nor the rights of others. ON Semiconductor products are not designed, intended, or authorized for use as a critical component in life support systems or any FDA Class 3 medical devices or medical devices with a same or similar classification in a foreign jurisdiction or any devices intended for implantation in the human body. Should Buyer purchase or use ON Semiconductor products for any such unintended or unauthorized application, Buyer shall indemnify and hold ON Semiconductor and its officers, employees, subsidiaries, affiliates, and distributors harmless against all claims, costs, damages, and expenses, and reasonable attorney fees arising out of, directly or indirectly, any claim of personal injury or death associated with such unintended or unauthorized use, even if such claim alleges that ON Semiconductor was negligent regarding the design or manufacture of the part. ON Semiconductor is an Equal Opportunity/Affirmative Action Employer. This literature is subject to all applicable copyright laws and is not for resale in any manner.

PUBLICATION ORDERING INFORMATION

LITERATURE FULFILLMENT:

Email Requests to: orderlit@onsemi.com

ON Semiconductor Website: www.onsemi.com

TECHNICAL SUPPORT

North American Technical Support:
Voice Mail: 1 800-282-9855 Toll Free USA/Canada
Phone: 011 421 33 790 2910

Europe, Middle East and Africa Technical Support:

Phone: 00421 33 790 2910

For additional information, please contact your local Sales Representative