

# Step-Down Switching Regulator Evaluation Board



Part Number: LM2594APDBCKGEVB

ON Semiconductor



## Evaluation/Development Tool Description

The LM2594 regulator is circuit ideally suited for easy and convenient design of a step down switching regulator (buck converter). It is capable of driving a 0.5 A load with excellent line and load regulation. This device is available in adjustable output version and it is internally compensated to minimize the number of external components to simplify the power supply design. Demoboard size: 28mm x 25mm

## Features

- Adjustable Output Voltage Range 1.23 V 37 V
- Guaranteed 0.5 A Output Load Current
- Wide Input Voltage Range up to 40 V
- 150 kHz Fixed Frequency Internal Oscillator
- TTL Shutdown Capability
- Low Power Standby Mode, typ 50  $\mu$ A
- Thermal Shutdown and Current Limit Protection
- Internal Loop Compensation
- Moisture Sensitivity Level (MSL) Equals 1
- PbFree Packages are Available

## Applications

- Simple HighEfficiency StepDown (Buck) Regulator
- Efficient PreRegulator for Linear Regulators
- OnCard Switching Regulators
- Positive to Negative Converter (BuckBoost)
- Negative StepUp Converters
- Power Supply for Battery Chargers



## Bill of Materials for the LM2594APDBCKGEVB Evaluation Board

Designator	Quantity	Description	Value	Tolerance	Footprint	Manufacturer	Manufacturer Part Number	Substitution Allowed	Lead Free
R1	1	Resistor	1.0 k	1%	Axial	Panasonic - ECG	ERO-S2PHF1001	Yes	Yes
R2	1	Resistor	3.0 k	1%	Axial	Panasonic - ECG	ERO-S2PHF3002	Yes	Yes
C1	1	Electrolytic Capacitor	100 uF / 50 V	10%	Axial	Nichicon	UPM1C221MPD	Yes	Yes
C2	1	Electrolytic Capacitor	220 uF / 16 V	10%	Axial	Nichicon	UPM1H101MPD6	Yes	Yes
C3	1	Capacitor	1.5 nF	10%	Radial	Kemet	C317C152K1R5TA	Yes	Yes
L1	1	Inductor	100 uH	20%	RFB0810	Coilcraft	RFB0810-101	No	Yes
D1	1	Schottky Rectifier, 1.0 A, 40 V	1N5819	-	Axial	ON Semiconductors	1N5819RLG	No	Yes
IC1	1	Controller	LM2594	-	PDIP8	ON Semiconductors	LM2594PADJG	No	Yes
+Vin, +Vout, GND, GND	4	Test Pins	-	-	1.3 mm	Various	Various	Yes	Yes



### Schematic for the LM2594APDBCKGEVB – LM2594 0.5A BUCK DEMO BD

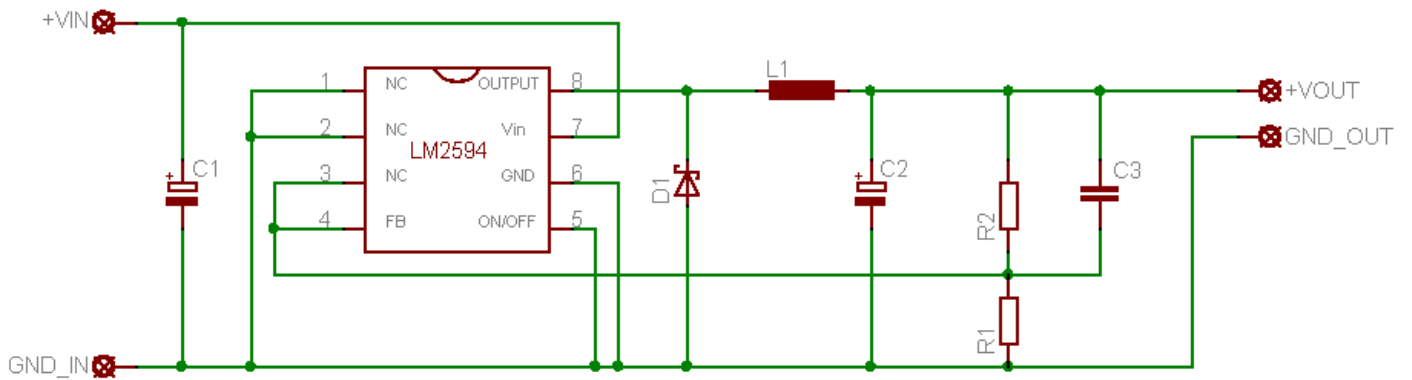

## Test Procedure for the LM2594APDBCKGEVB

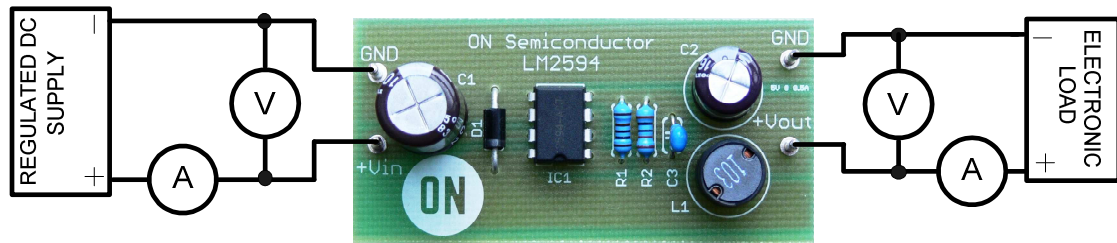

Figure 1: Test Setup

### Test Procedure:

1. Connect the test setup as shown in Figure 1.
2. Apply an input voltage,  $V_{cc} = 24\text{ V}$
3. Apply  $I_{out} = 0\text{ mA}$  load.
4. Check that  $V_{out}$  is  $5.0\text{ V}$
5. Increase  $I_{out}$  load to  $500\text{ mA}$
6. Check that  $V_{out}$  is  $5.0\text{ V}$
7. Power down the load
8. Power down  $V_{cc}$
9. End of test