

# Counter nut - A-INL-M25-N-S

1411243

<https://www.phoenixcontact.com/pc/products/1411243>

Please be informed that the data shown in this PDF document is generated from our Online Catalog. Please find the complete data in the user documentation. Our General Terms of Use for Downloads are valid.

Counter nut, for threads M25 x 1.5, color: silver



## Commercial Data

|                                      |                     |
|--------------------------------------|---------------------|
| Item number                          | 1411243             |
| Packing unit                         | 100 pc              |
| Minimum order quantity               | 1 pc                |
| Product Key                          | BF7DZX              |
| Catalog Page                         | Page 688 (C-2-2019) |
| GTIN                                 | 4046356923743       |
| Weight per Piece (including packing) | 8.662 g             |
| Weight per Piece (excluding packing) | 8.412 g             |
| Customs tariff number                | 74198090            |
| Country of origin                    | IN                  |

# Counter nut - A-INL-M25-N-S

1411243

<https://www.phoenixcontact.com/pc/products/1411243>

## Technical Data

### Product properties

|              |          |
|--------------|----------|
| Product type | Flat nut |
| Thread type  | M25      |

### Dimensions

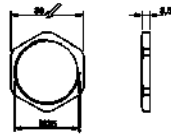
|                             |  |
|-----------------------------|--|
| Dimensional drawing         |  |
| Length                      | 3.5 mm   |
| Connecting thread diameter  | 25 mm  |
| Wrench size, counter nut    | 30 mm  |
| Hexagon angular dimension   | 33.5 mm  |
| Thread type connection side | M25 x 1.5  |
| Thread pitch                | 1.5 mm   |

### Material specifications

|          |                      |
|----------|----------------------|
| Color    | silver               |
| Material | Brass, nickel-plated |

### Cable / line

|              |     |
|--------------|-----|
| Halogen-free | yes |
|--------------|-----|

### Environmental and real-life conditions

#### Ambient conditions

|                                 |                   |
|---------------------------------|-------------------|
| Ambient temperature (operation) | -70 °C ... 220 °C |
|---------------------------------|-------------------|

# Counter nut - A-INL-M25-N-S

1411243

<https://www.phoenixcontact.com/pc/products/1411243>



## Drawings

Dimensional drawing

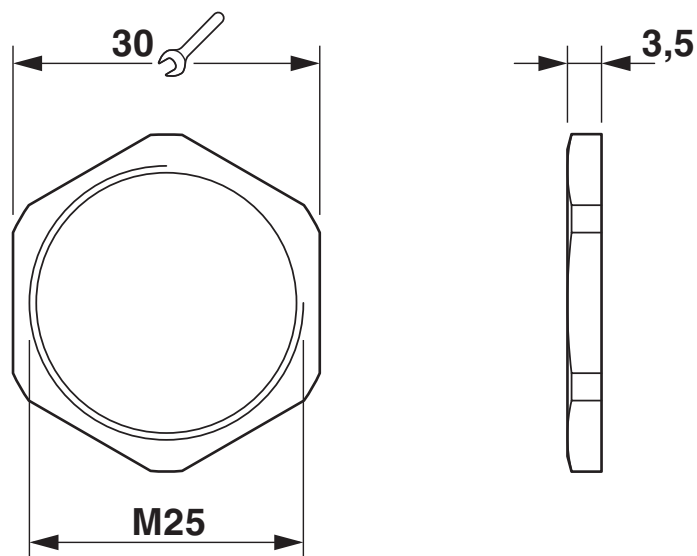

# Counter nut - A-INL-M25-N-S



1411243

<https://www.phoenixcontact.com/pc/products/1411243>

## Classifications

### ECLASS

|               |          |
|---------------|----------|
| ECLASS-9.0    | 27144424 |
| ECLASS-10.0.1 | 27144424 |
| ECLASS-11.0   | 27144424 |

### ETIM

|          |          |
|----------|----------|
| ETIM 8.0 | EC000940 |
|----------|----------|

### UNSPSC

|             |          |
|-------------|----------|
| UNSPSC 21.0 | 31161700 |
|-------------|----------|

# Counter nut - A-INL-M25-N-S



1411243

<https://www.phoenixcontact.com/pc/products/1411243>

## Environmental Product Compliance

|            |  |
|------------|--|
| REACH SVHC | Lead 7439-92-1   |
| China RoHS | Environmentally Friendly Use Period = 50 years   |
|            | For information on hazardous substances, refer to the manufacturer's declaration available under "Downloads" |

Phoenix Contact 2023 © - all rights reserved  
<https://www.phoenixcontact.com>

PHOENIX CONTACT GmbH & Co. KG  
Flachsmarktstraße 8  
D-32825 Blomberg  
+49 (0) 5235-3 00  
[info@phoenixcontact.com](mailto:info@phoenixcontact.com)