

High Current Relay 150



Features

- Limiting continuous current 150 A at 85°C
- Current switching ability up to 300 A
- Suitable for voltage levels up to 42 V
- Heat, moisture and vibration resistant
- Minimal contact resistance
- Dustproof and sealed versions

Typical Applications

- Engine control
- Glow Plug
- Heated front screen
- Preheating systems (e.g. for diesel engines, catalytic converters)
- Switches for loading ramps

Please contact Tyco Electronics for relay application support.



132_305

Design

- ELV/RoHS/WEEE compliant
- Dustproof; protection class IP 54 to IEC 529 (EN 60 529)
- Sealed: sealing in accordance with IEC 68; immersion cleanable: protection class IP67 to IEC 529 (EN 60 529)

Weight

Approx. 220 g (7.8 oz.)

Nominal Voltage

12 V, 24 V or 42 V

Terminals

- Quick connect terminals (coil)
- Screw terminals (load)

Conditions

All parametric, environmental and endurance tests are performed according to EIA Standard RS-407-A at standard test conditions unless otherwise noted:
23°C ambient temperature,
20 - 50% RH, 998.9 ±33.9 hPa.

For general storage and processing recommendations please refer to our Application Notes and especially to *Storage* in the "Glossary" page 23 or at <http://relays.tycoelectronics.com/apnotes/>

Disclaimer

All technical performance data apply to the relay as such, specific conditions of the individual application are not considered. Please always check the suitability of the relay for your intended purpose. We do not assume any responsibility or liability for not complying herewith. We recommend to complete our questionnaire and to request our technical service. Any responsibility for the application of the product remains with the customer only. All specifications are subject to change without notification. All rights of Tyco Electronics are reserved.

High Current Relay 150

Dimensional Drawing

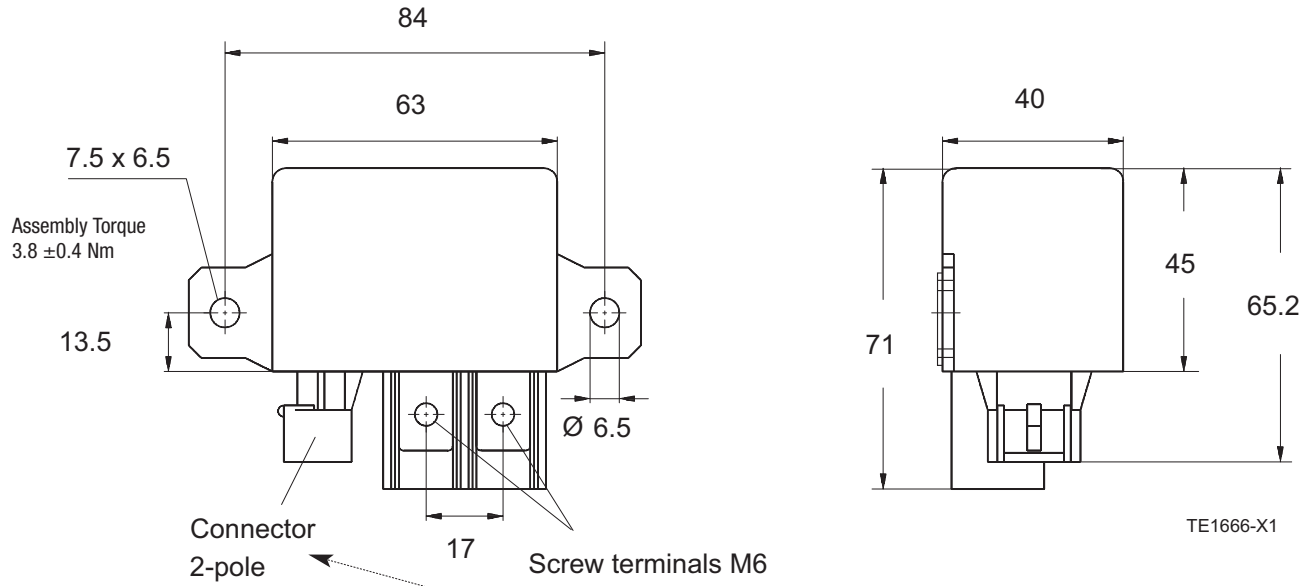

Connector Information
AMP SUPERSEAL 1.5 SERIES

- Coil side
 - Receptacle connector 282080-1
 - Single wire seal 281934-2
 - Contact 282110-1
 Load side
 - Thimble 710026

View of the Terminals (bottom view)

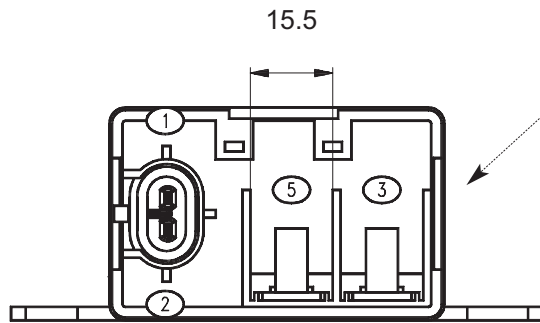

TE1667-61

High Current Relay 150

Contact Data

Contact configuration	1 Make contact/ 1 Form A		1 Double make contact/ 1 Form X	
Circuit symbol (see also Pin Assignment)				
Rated voltage	12 V	12 V	24 V	24 V
Rated current				
Cable 16 mm ²	130 A	120 A	120 A	100 A
Cable 25 mm ²	150 A	130 A	135 A	120 A
Limiting continuous current				
Cable 16 mm ²	23°C	150 A	130 A	140 A
	85°C	130 A	120 A	120 A
	125°C	70 A	60 A	60 A
Cable 25 mm ²	23°C	200 A	180 A	180 A
	85°C	150 A	130 A	135 A
	125°C	80 A	70 A	70 A
Contact material	AgNi0.15	AgSnO ₂	AgNi0.15	AgSnO ₂
Max. switching current ¹⁾				
On ²⁾	150 A	300 A	150 A	300 A
Off	150 A	300 A	150 A	300 A
Min. recommended load ³⁾	1 A at 5 V			
Voltage drop at 100 A (initial)	Typ. 50 mV, 100 mV max.	Typ. 70 mV, 200 mV max.	Typ. 70 mV, 200 mV max.	Typ. 70 mV, 400 mV max.
Mechanical endurance (without load)	> 10 ⁷ operations			
Electrical endurance at 23°C; 1 s: on, 5 s: off (example of resistive load)	> 3 x 10 ⁴ operations 150 A, 13.5 V	> 5 x 10 ⁴ operations 300 A, 13.5 V	> 1 x 10 ⁴ operations 150 A, 27 V	> 5 x 10 ⁴ operations 200 A, 27 V
Max switching rate at nominal load	6 operations per minute (0.1 Hz)			

1) The values apply to a resistive or inductive load with suitable spark suppression and at maximum 13.5 V for 12 V or 27 V for 24 V load voltages.

2) For a load current duration of maximum 3 s for a make/break ratio of 1:10.

3) See chapter Diagnostics of Relays in our Application Notes page 31 or consult the internet at <http://relays.tycoelectronics.com/appnotes/>

Operating Voltage Range

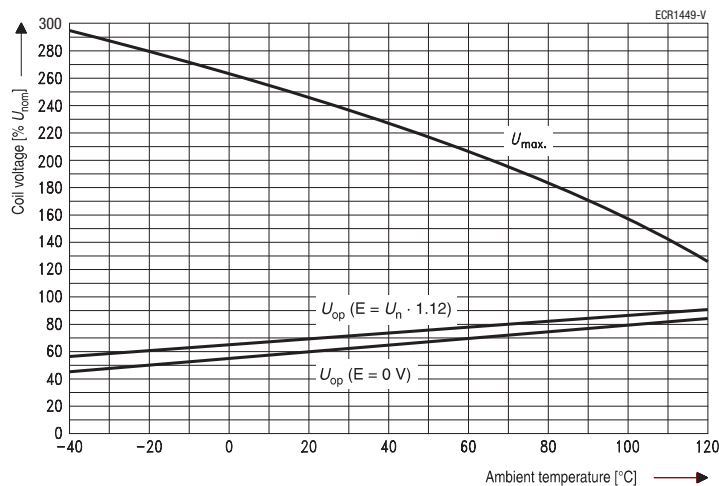

Does not take into account
the temperature rise due to
the contact current
E = pre-energization

High Current Relay 150

Circuit Diagram

AR
1 Make contact/1 Form A
with Resistor

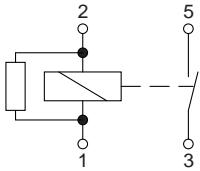

XR
1 Double make contact/1 Form X
with Resistor

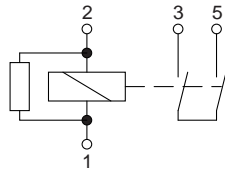

Coil Data

Available for nominal voltages	12 V / 24 V (other coils on request)
Nominal power consumption of the unsuppressed coil at nominal voltage	3.3 W
Nominal power consumption at nominal voltage with suppression resistor	4.1 W
Test voltage winding/contact	1000 VAC _{rms}
Maximum ambient temperature range	-40 to +125°C
Operate time at nominal voltage	Typ. 25 ms
Release time at nominal voltage ¹⁾	Typ. 8 ms

¹⁾ For unsuppressed relay coil.

Note:

A low resistive suppression device in parallel to the relay coil increases the release time and reduces the lifetime caused by increased erosion and/or higher risk of contact tack welding.

Mechanical Data

Cover retention	
Axial force	500 N
Pull force	500 N
Push force	500 N
Terminals	
Pull force	150 N
Push force	150 N
Resistance to bending, force applied to front	20 N ¹⁾
Resistance to bending, force applied to side	20 N ¹⁾
Max. torsion of screw bolts	5 Nm
Enclosures	Protects relay from dust. For use in passenger compartment or enclosures.
Dust cover	Please refer to the Application Notes in this catalog.

¹⁾ Values apply 2 mm from the end of the terminal. When the force is removed, the terminal must not have moved by more than 0.3 mm.

High Current Relay 150

Environmental Conditions				
Temperature range, storage	Refer to <i>Storage</i> in the "Glossary" catalog page 23 or http://relays.tycoelectronics.com/apnotes/			
Test	Relevant standard	Testing as per	Dimension	Comments
Temperature cycling	IEC 68-2-14	Nb	10 cycles	-40/+85°C (5°C per min)
Dry heat	IEC 68-2-2	Ba	500 h	100°C
Damp heat constant	IEC 68-2-3	Ca	500 h	40°C, 93% RH
Industrial atmosphere	IEC 68-2-60	Method 4	21 days	25°C
Corrosive gas	IEC 68-2-42	10 ±2 cm ³ /m ³ SO ₂	10 days	
	IEC 68-2-43	1 ±0.3 cm ³ /m ³ H ₂ S	10 days	
Vibration resistance	IEC 68-2-6 (sine sweep)		10 - 200 Hz 5 g	No change in the switching state > 10 μs Valid for NC contacts, NO contact values significantly higher
Shock resistance	IEC 68-2-27 (half sine form single pulses)		6 ms min. 20 g	
Load dump	ISO 7637-1 (12 V)	Test pulse 5	Vs = +86.5 V	
	ISO 7637-2 (24 V)	Test pulse 5	Vs = +200 V	
Drop test	Capable of meeting specifications after 1.0 m (3.28 ft) drop onto concrete			
Flammability	UL94-HB or better (meets FMVSS 302) ¹⁾			

¹⁾ FMVSS: Federal Motor Vehicle Safety Standard.

Ordering Information

Part Numbers (see table below for coil data)		Nominal Voltage	Circuit/Contact Arrangement	Contact Material	Protection Class according to IEC 529 (EN 60 529)
Relay Description	Part Number				
12 V					
V23132-A2001-A100	1393315-1	12 V	AR/1 Form A	AgNi0.15	IP54
V23132-A2001-A200	1393315-2	12 V	AR/1 Form A	AgSnO ₂	IP54
V23132-A2001-B100	1393315-3	12 V	AR/1 Form A	AgNi0.15	IP67
V23132-A2001-B200	1416010-1	12 V	AR/1 Form A	AgSnO ₂	IP67
24 V					
V23132-B2002-A100	1393315-8	24 V	XR/1 Form X	AgNi0.15	IP54
V23132-B2002-A200	1393315-9	24 V	XR/1 Form X	AgSnO ₂	IP54
V23132-B2002-B100	1-1414428-0	24 V	XR/1 Form X	AgNi0.15	IP67
V23132-B2002-B200	1-1393315-1	24 V	XR/1 Form X	AgSnO ₂	IP67

Coil Versions

Coil Data for HCR 150	Rated Coil Voltage (V)	Coil Resistance		Must Operate Voltage (V)	Must Release Voltage (V)	Allowable Overdrive ¹⁾ Voltage (V)	
		without suppression device ±10%	with suppression device ±10%			at 23°C	at 85°C
		(Ω)	(Ω)				
V23132-**001-****	12	44	37	7.2	1.2	27	20
V23132-**002-****	24	178	141	14.4	2.4	54	38

¹⁾ Allowable overdrive is stated with no load applied and minimum coil resistance.

Standard Delivery Packs (orders in multiples of delivery pack)

HCR 150: 10 pieces