

EZ-10 SERIES

Water Detection Sensor

GD

Metal-sheet
Double-feed Detection

TH

Hot Melt Glue Detection

LA-T

Wire Flaw Detection

EZ-10

Water Detection

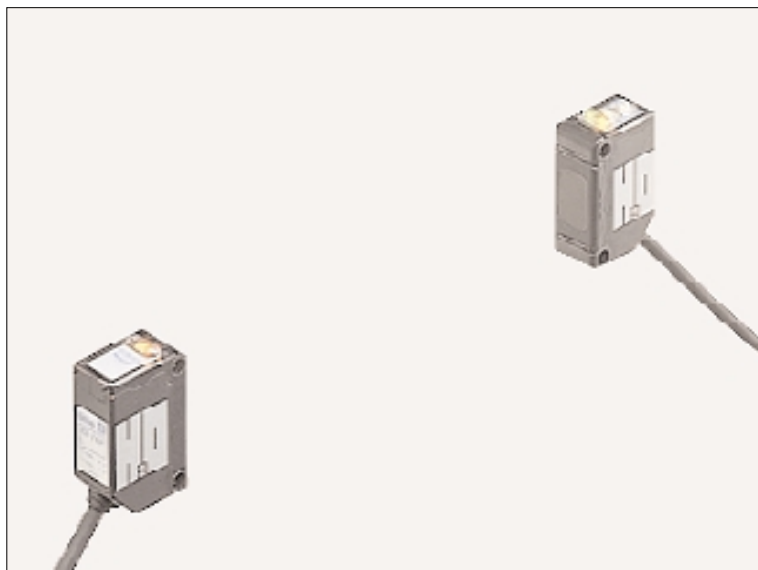

Detects
water...reliably!



Strong penetration power

As the penetration power is strong, its beam can pass through not only translucent containers (PFA tanks, etc.) but also opaque containers of shampoo bottles, etc., and can reliably detect the liquid inside.

Penetration in case of an empty container (Typical)

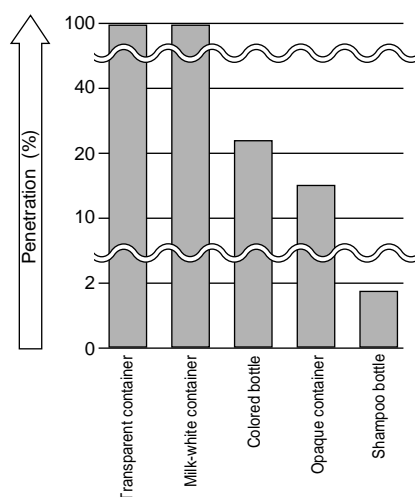

※The graph above is merely a guideline. Penetration power changes due to container material, thickness and color. We strongly recommend that you conduct verification tests prior to use.

Not affected by drops, bubbles or froth

It is possible to set its sensitivity adjuster so that water drops, bubbles in the water, or froth on the water surface are not detected.

Water drops



Bubbles



Froth



Adjacent sensor mounting possible

Several sensors can be mounted adjacently by fitting optional slit masks. Further, they can detect the liquid level accurately.

Plug-in connector type is available

Plug-in connector type which enables connection / disconnection of the cable by one-touch is available. Anyone can easily replace the sensor in a minute.

Output operation selectable

Light-ON or Dark-ON operation can be selected. The output operation can be changed easily.

IP67 protection

The sensor can be hosed down because of its IP67 construction and the non-corrosive stainless steel sensor mounting bracket.

Note: However, take care that if it is exposed to water splashes during operation, it will detect the splashed water itself.

APPLICATIONS

Detecting level of aqueous solution in resin tank

It can reliably detect a liquid even in an opaque container.

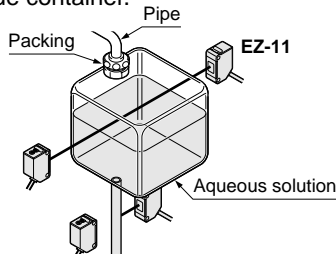

Detecting the boundary between water and oil

Since it does not detect oil, it can reliably detect the boundary between water and oil.

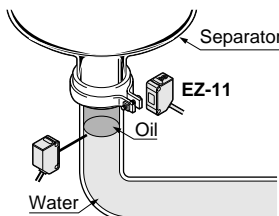

Detecting presence of liquid in colored bottle

Aqueous liquids in translucent colored bottles can be reliably detected.

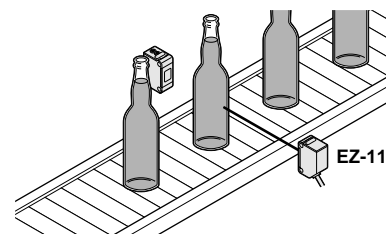

ORDER GUIDE

Type	Appearance	Sensing range (Note)	Model No.	Output
NPN output		5 m 16.404 ft (without container or pipe)	EZ-11	NPN open-collector transistor
PNP output			EZ-11-PN	PNP open-collector transistor

NOTE: Mounting bracket is not supplied with the sensor. Please select from the range of optional sensor mounting brackets (five types).

Note: The sensing range shortens depending on the thickness, material, color, etc., of the container or pipe.

5 m 16.404 ft cable length type and plug-in connector type

5 m 16.404 ft cable length type (Standard: 2 m 6.562 ft) and plug-in connector type (Standard: cable type) are available.

• Table of Model Nos.

Type	Standard	5 m 16.404 ft cable length type	Plug-in connector type (Note)
NPN output	EZ-11	EZ-11-C5	EZ-11-J
PNP output	EZ-11-PN	—————	EZ-11-PN-J

Note: Please order the suitable mating cable separately for plug-in connector type.

• Mating cable for plug-in connector type (2 cables are required)

Type	Model No.	Description
Straight	CN-24E-C2	Length: 2 m 6.562 ft
	CN-24E-C5	Length: 5 m 16.404 ft
Elbow	CN-24EL-C2	Length: 2 m 6.562 ft
	CN-24EL-C5	Length: 5 m 16.404 ft

0.2 mm² 4-core cabtype cable with connector on one end
Cable outer diameter: $\phi 3.7$ mm $\phi 0.146$ in

• CN-24E-C2, CN-24E-C5

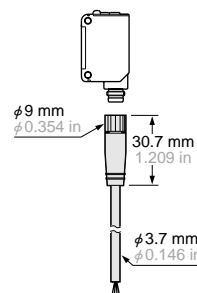

• CN-24EL-C2, CN-24EL-C5

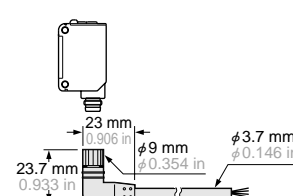

Metal-heat Double-test Detection

GD

Hot Melt/Glue Detection

TH

Wire Flaw Detection

LA-T

Water Detection

EZ-10

OPTIONS

Designation	Model No.	Description	
Round slit mask	OS-CX-05 (Slit size $\phi 0.5$ mm) ($\phi 0.020$ in)	Slit on one side	• Sensing range: 200 mm 7.874 in
		Slit on both sides	• Sensing range: 10 mm 0.394 in
	OS-CX-1 (Slit size $\phi 1$ mm) ($\phi 0.039$ in)	Slit on one side	• Sensing range: 400 mm 15.748 in
		Slit on both sides	• Sensing range: 60 mm 2.362 in
	OS-CX-2 (Slit size $\phi 2$ mm) ($\phi 0.079$ in)	Slit on one side	• Sensing range: 1 m 3.281 ft
		Slit on both sides	• Sensing range: 250 mm 9.843 in
Rectangular slit mask	OS-CX-05 × 6 (Slit size 0.5×6 mm) (0.020×0.236 in)	Slit on one side	• Sensing range: 800 mm 31.496 in
		Slit on both sides	• Sensing range: 250 mm 9.843 in
	OS-CX-1 × 6 (Slit size 1×6 mm) (0.039×0.236 in)	Slit on one side	• Sensing range: 1.3 m 4.265 ft
		Slit on both sides	• Sensing range: 600 mm 23.622 in
	OS-CX-2 × 6 (Slit size 2×6 mm) (0.079×0.236 in)	Slit on one side	• Sensing range: 2 m 6.562 ft
		Slit on both sides	• Sensing range: 1.3 m 4.265 ft
Sensor mounting bracket (Note 1)	MS-CX2-1	Foot angled mounting bracket (Two brackets are required.)	
	MS-CX2-2	Foot biangled mounting bracket (Two brackets are required.)	
	MS-CX2-4	Protective mounting bracket (Two brackets are required.)	
	MS-CX2-5	Back biangled mounting bracket (Two brackets are required.)	
	MS-CX-3	Back angled mounting bracket (Two brackets are required.)	
Universal sensor mounting stand (Note 2)	MS-AJ1	Horizontal mounting type	Basic assembly
	MS-AJ2	Vertical mounting type	Basic assembly
	MS-AJ1-A	Horizontal mounting type	Lateral arm assembly
	MS-AJ2-A	Vertical mounting type	Lateral arm assembly

Notes: 1) The plug-in connector type sensor does not allow use of some sensor mounting brackets because of the protrusion of the connector.
2) Refer to p.332~ for details of the universal sensor mounting stand.

Round slit mask

Used for narrowing the beam for cases when detecting water or other substances inside slender pipes. Fitted on the front face of the sensor with one-touch.

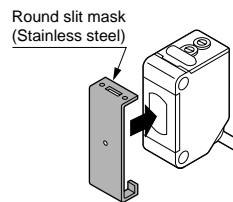

Rectangular slit mask

Used for narrowing the beam for cases when detecting water or other substances inside slender pipes. Fitted on the front face of the sensor with one-touch.

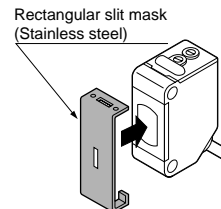

Sensor mounting bracket

• MS-CX2-1

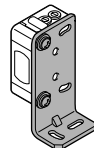

Two M3 (length 12 mm 0.472 in) screws with washers are attached.

• MS-CX2-2

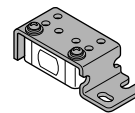

Two M3 (length 12 mm 0.472 in) screws with washers are attached.

• MS-CX2-4

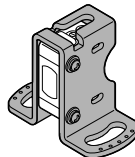

Two M3 (length 14 mm 0.551 in) screws with washers are attached.

• MS-CX2-5

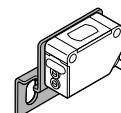

Two M3 (length 12 mm 0.472 in) screws with washers are attached.

• MS-CX-3

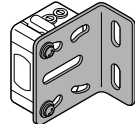

Two M3 (length 12 mm 0.472 in) screws with washers are attached.

Universal sensor mounting stand

• MS-AJ1

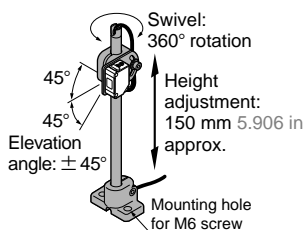

• MS-AJ2

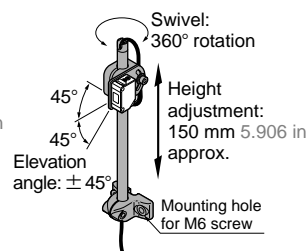

• MS-AJ1-A

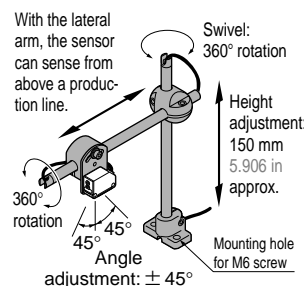

• MS-AJ2-A

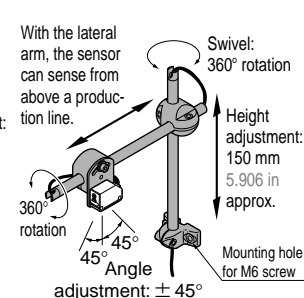

SPECIFICATIONS

Item	Type	NPN output	PNP output
	Model No.	EZ-11	EZ-11-PN
Sensing range		5 m 16.404 ft (without container or pipe)(Note 1)	
Sensing object		φ 12 mm φ0.472 mm or more liquid which contains water, or opaque object (Note 2)	
Supply voltage		12 to 24 V DC ± 10 % Ripple P-P 10 % or less	
Current consumption		Emitter: 25 mA or less, Receiver: 25 mA or less	
Output		NPN open-collector transistor • Maximum sink current: 100 mA • Applied voltage: 30 V DC or less (between output and 0 V) • Residual voltage: 1.5 V or less (at 100 mA sink current) 0.4 V or less (at 16 mA sink current)	PNP open-collector transistor • Maximum source current: 100 mA • Applied voltage: 30 V DC or less (between output and +V) • Residual voltage: 1.5 V or less (at 100 mA source current) 0.4 V or less (at 16 mA source current)
	Utilization category	DC-12 or DC-13	
	Output operation	Switchable either Light-ON or Dark-ON	
	Short-circuit protection	Incorporated	
Response time		12 ms or less	
Operation indicator		Orange LED (lights up when the output is ON), located on the receiver	
Stability indicator		Green LED (lights up under stable light received condition or stable dark condition), located on the receiver	
Power indicator		Orange LED (lights up when the power is ON), located on the emitter	
Sensitivity adjuster		Continuously variable adjuster	
Environmental resistance	Pollution degree	3 (Industrial environment)	
	Protection	IP67 (IEC)	
	Ambient temperature	0 to + 55 °C + 32 to + 131 °F (No dew condensation or icing allowed), Storage: - 30 to + 70 °C - 22 to + 158 °F	
	Ambient humidity	35 to 85 % RH, Storage: 35 to 85 % RH	
	Ambient illuminance	Sunlight: 10,000 lx at the light-receiving face, Incandescent light: 3,000 lx at the light-receiving face	
	EMC	EN 50081-2, EN 50082-2, EN 60947-5-2	
	Voltage withstandability	1,000 V AC for one min. between all supply terminals connected together and enclosure	
	Insulation resistance	20 MΩ, or more, with 250 V DC megger between all supply terminals connected together and enclosure	
	Vibration resistance	10 to 500 Hz frequency, 3 mm 0.118 in amplitude (20 G max.) in X, Y and Z directions for two hours each	
Shock resistance	500 m/s ² acceleration (50 G approx.) in X, Y and Z directions for three times each		
Emitting element		Infrared LED (modulated)	
Material		Polycarbonate	
Cable		0.2 mm ² 3-core (emitter: 2-core) oil resistant cabtyre cable, 2 m, 6.562 ft long	
Cable extension		Extension up to total 100 m 328.084 ft is possible, for both emitter and receiver, with 0.3 mm ² , or more, cable.	
Weight		Emitter: 45 g approx., Receiver: 50 g approx.	
Accessory		Adjusting screwdriver: 1 pc.	

Notes: 1) The sensing range shortens depending on the thickness, material, color, etc., of the container or pipe.

2) If there are two slits on both sides, the size of those slits represents the min. sensing object.

Metal-sheet
Double-feed Detection

GD

Hot Melt Glue Detection

TH

Wire Flaw Detection

LA-T

Water Detection

EZ-10

EZ-10

I/O CIRCUIT DIAGRAMS

NPN output type

I/O circuit diagram

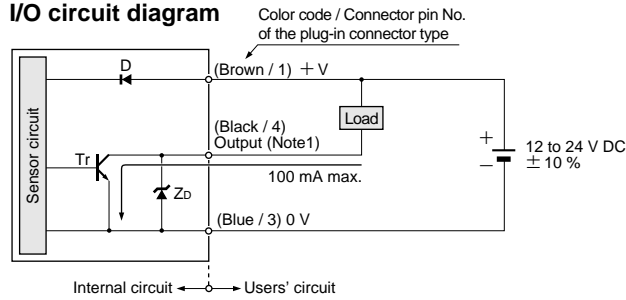

- Notes: 1) The emitter does not incorporate the output.
 2) When the mating cable is connected to the plug-in connector type sensor, the white wire of the mating cable is not connected.

Symbols ... D : Reverse supply polarity protection diode
 Zd: Surge absorption zener diode
 Tr: NPN output transistor

Wiring diagram

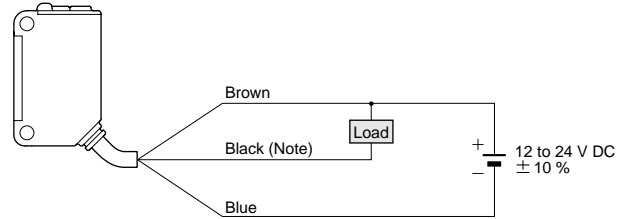

Note: The emitter does not incorporate the black wire.

Connector pin position (plug-in connector type)

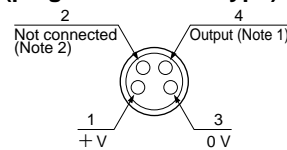

- Notes: 1) The emitter does not incorporate the output.
 2) When the mating cable is connected to the plug-in connector type sensor, the white wire of the mating cable is not connected.

PNP output type

I/O circuit diagram

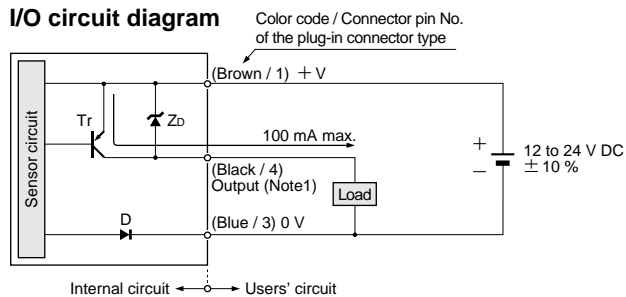

- Notes: 1) The emitter does not incorporate the output.
 2) When the mating cable is connected to the plug-in connector type sensor, the white wire of the mating cable is not connected.

Symbols ... D : Reverse supply polarity protection diode
 Zd: Surge absorption zener diode
 Tr: PNP output transistor

Wiring diagram

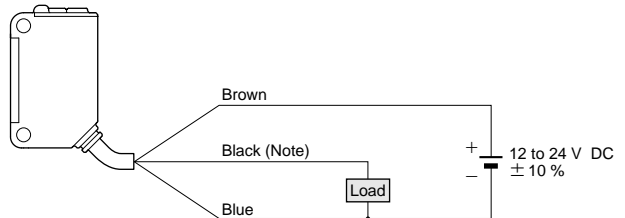

Note: The emitter does not incorporate the black wire.

Connector pin position (plug-in connector type)

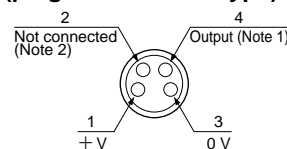

- Notes: 1) The emitter does not incorporate the output.
 2) When the mating cable is connected to the plug-in connector type sensor, the white wire of the mating cable is not connected.

SENSING CHARACTERISTICS (TYPICAL)

Correlation between setting distance and excess gain

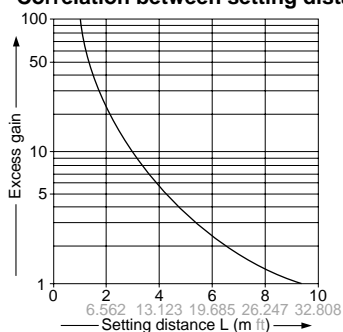

SENSING CHARACTERISTICS (TYPICAL)

Parallel deviation

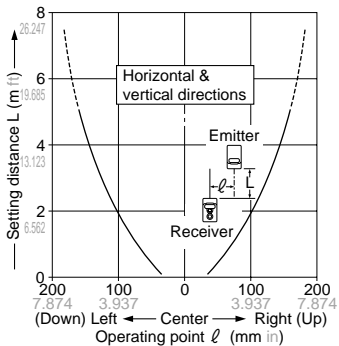

Angular deviation

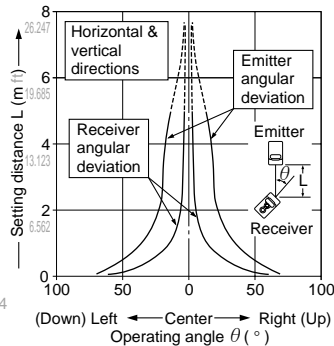

Parallel deviation with round slit masks (φ0.5 mm φ0.020 in)

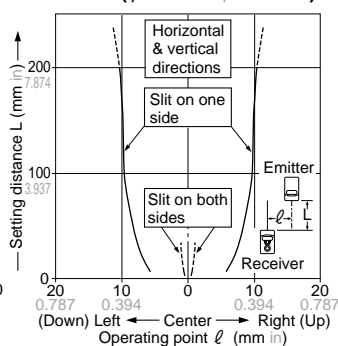

Parallel deviation with round slit masks (φ1 mm φ0.039 in)

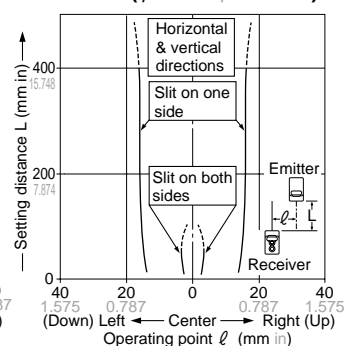

Parallel deviation with round slit masks (φ2 mm φ0.079 in)

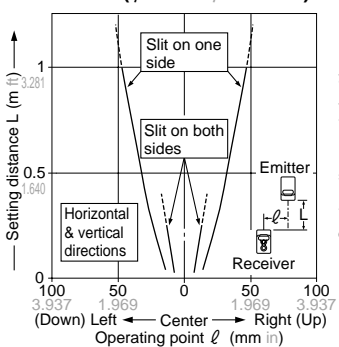

Parallel deviation with rectangular slit masks (0.5 X 6 mm 0.020 X 0.236 in)

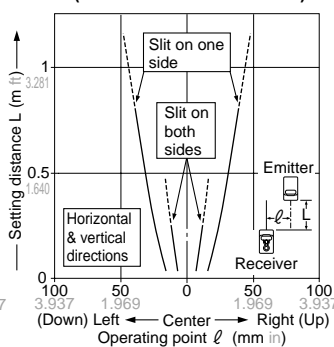

Parallel deviation with rectangular slit masks (1 X 6 mm 0.039 X 0.236 in)

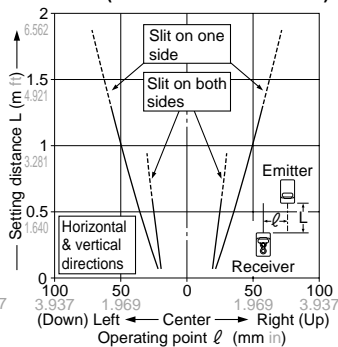

Parallel deviation with rectangular slit masks (2 X 6 mm 0.079 X 0.236 in)

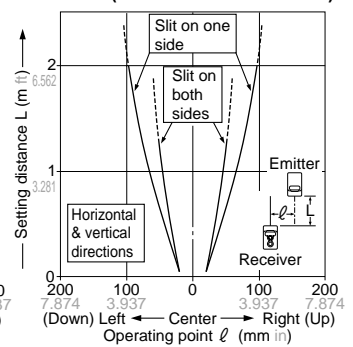

PRECAUTIONS FOR PROPER USE

Refer to p.1135~ for general precautions.



This product is not a safety sensor. Its use is not intended or designed to protect life and prevent body injury or property damage from dangerous parts of machinery. It is a normal object detection sensor.

Mounting

- The tightening torque should be 0.5 N·m or less.

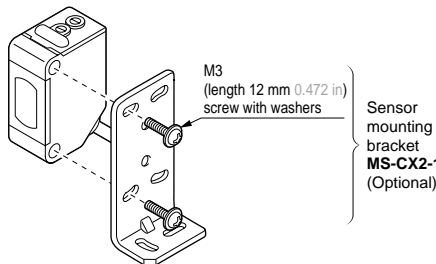

Wiring

- Make sure that the power supply is off while wiring.
- Verify that the supply voltage variation is within the rating.
- If power is supplied from a commercial switching regulator, ensure that the frame ground (F.G.) terminal of the power supply is connected to an actual ground.
- In case noise generating equipment (switching regulator, inverter motor, etc.) is used in the vicinity of this product, connect the frame ground (F.G.) terminal of the equipment to an actual ground.
- Do not run the wires together with high voltage lines or power lines or put them in the same raceway. This can cause malfunction due to induction.
- When connecting the mating cable to the plug-in connector type sensor, the tightening torque should be 0.4 N·m or less.

Sensitivity adjustment

Step	Sensitivity adjuster	Operation
①		Turn the sensitivity adjuster fully counterclockwise to the minimum sensitivity position, MIN.
②		With the liquid which contains water or the opaque object absent (light received condition), turn the sensitivity adjuster slowly clockwise and confirm the point (A) where the sensor enters the 'Light' state operation.
③		With the liquid which contains water or the opaque object present (light interrupted condition), turn the sensitivity adjuster further clockwise until the sensor enters the 'Light' state operation and then bring it back to confirm point (B) where the sensor just returns to the 'Dark' state operation. (If the sensor does not enter the 'Light' state operation even when the sensitivity adjuster is turned fully clockwise, this extreme position is point (B).)
④		The position at the middle of points (A) and (B) is the optimum sensing position.

- Notes: 1) Use the accessory adjusting screwdriver to slowly turn the adjuster. Turning with excessive force will cause damage to the adjuster.
 2) Special emitting and receiving devices are used in this product. As they are easily affected by changes in ambient temperature and humidity, do the sensitivity adjustment under the actual operating conditions.
 3) Make sure to leave ample leeway when adjusting the sensitivity.

EZ-10

PRECAUTIONS FOR PROPER USE

Refer to p.1135~ for general precautions.

Operation mode switch

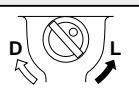
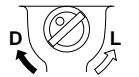
Operation mode switch	Operation
	Light-ON mode is obtained when the switch is turned fully counterclockwise (L side).
	Dark-ON mode is obtained when the switch is turned fully clockwise (D side).

Others

- Do not use during the initial transient time (100 ms) after the power supply is switched on.
- Avoid dust, dirt, and steam.
- Take care that the sensor does not come in direct contact with water, oil, grease or organic solvents, such as, thinner, etc.
- Take care that the sensor is not directly exposed to fluorescent light from a rapid-starter lamp or a high frequency lighting device, as it may affect the sensing performance.

Stability indicator

- The stability indicator (green) lights up when the incident light intensity has sufficient margin with respect to the operation level. If the incident light intensity level is such that the stability indicator lights up, stable sensing can be done without the light received operation and the light interrupted operation being affected by a change in ambient temperature or supply voltage.

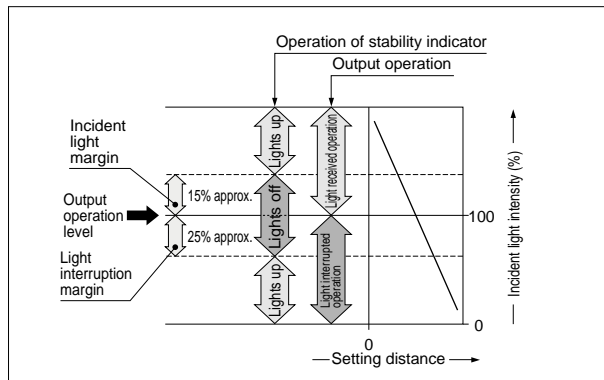

DIMENSIONS (Unit: mm in) The CAD data in the dimensions can be downloaded from the SUNX website: <http://www.sunx.co.jp/>

EZ-11 EZ-11-PN Sensor

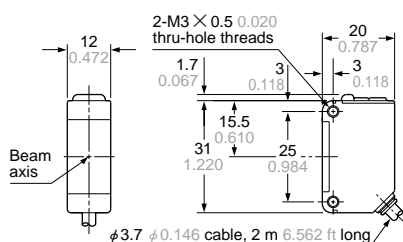
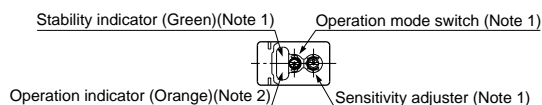

Notes: 1) Not incorporated on the emitter.
2) It is the power indicator (orange) on the emitter.

EZ-11-PN EZ-11-PN-J Sensor

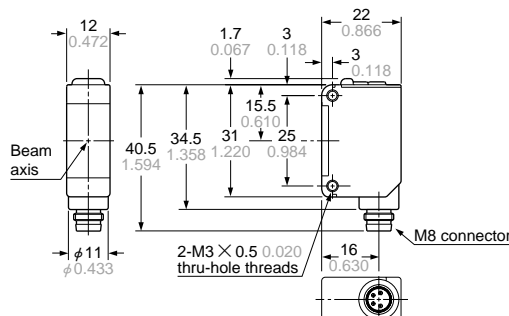
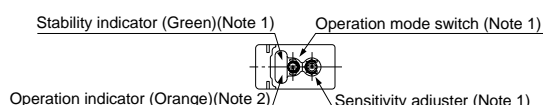

Notes: 1) Not incorporated on the emitter.
2) It is the power indicator (orange) on the emitter.

MS-CX2-1 Sensor mounting bracket (Optional)

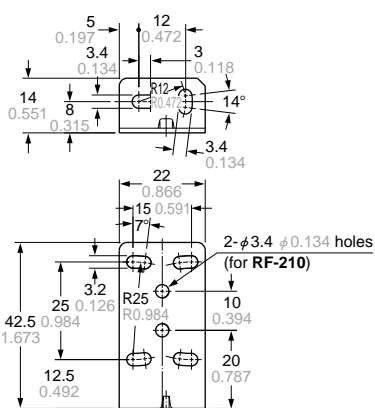

Material: Stainless steel (SUS304)
Two M3 (length 12 mm 0.472 in) screws with washers are attached.

Assembly dimensions Mounting drawing with the receiver of EZ-11(-PN)

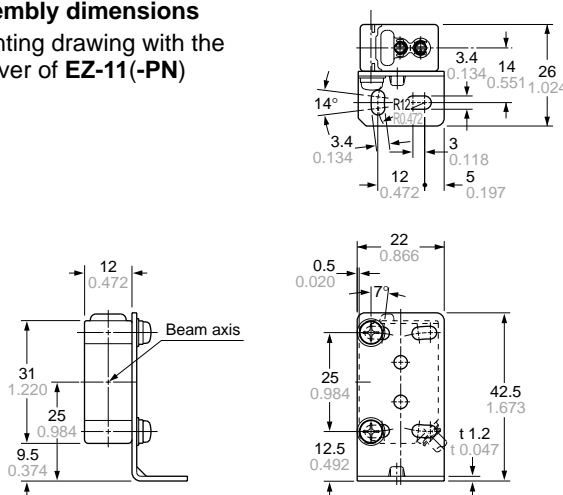

DIMENSIONS (Unit: mm in) The CAD data in the dimensions can be downloaded from the SUNX website: <http://www.sunx.co.jp/>

MS-CX2-2 Sensor mounting bracket (Optional)

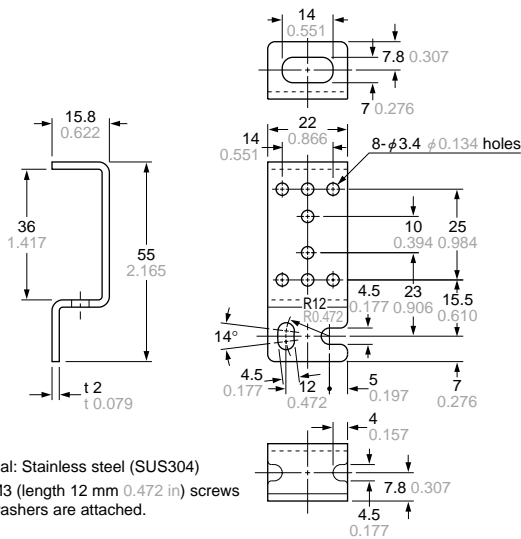

Assembly dimensions Mounting drawing with the receiver of EZ-11(-PN)

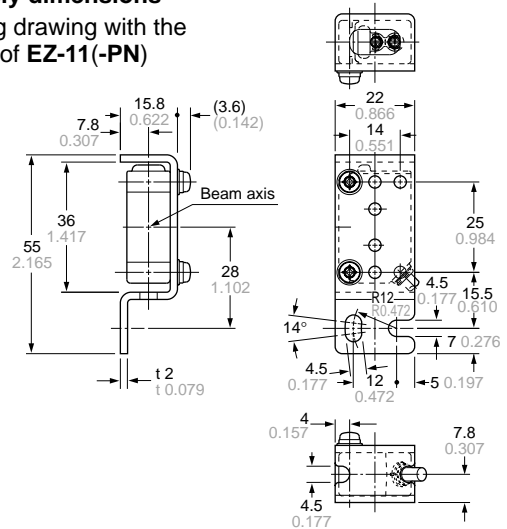

MS-CX2-4 Sensor mounting bracket (Optional)

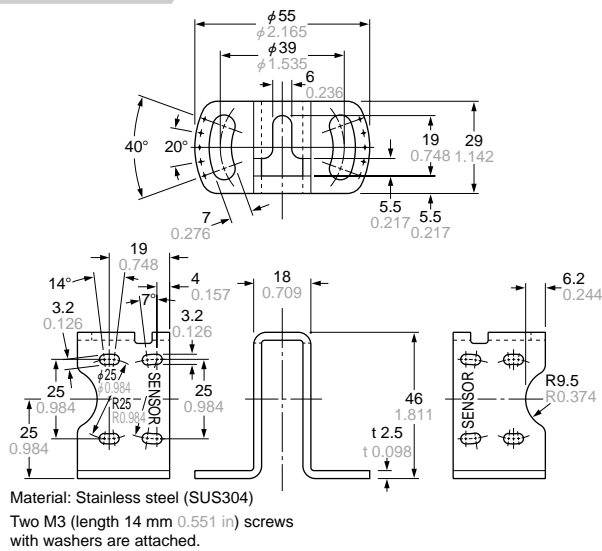

Assembly dimensions Mounting drawing with the receiver of EZ-11(-PN)

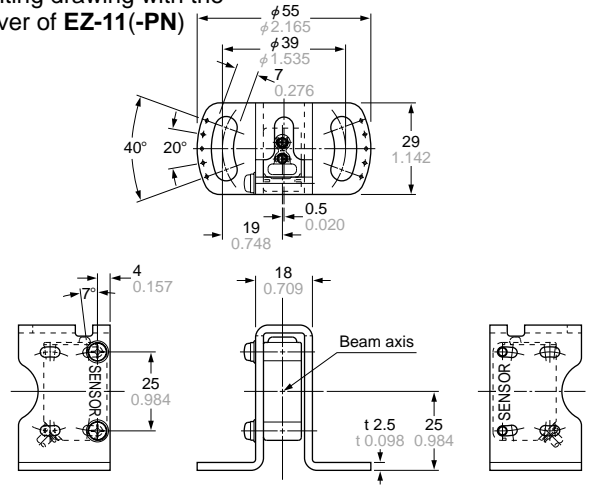

MS-CX2-5 Sensor mounting bracket (Optional)

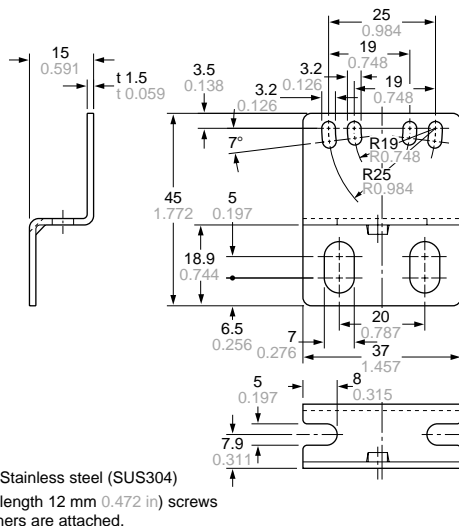

Assembly dimensions Mounting drawing with the receiver of EZ-11(-PN)

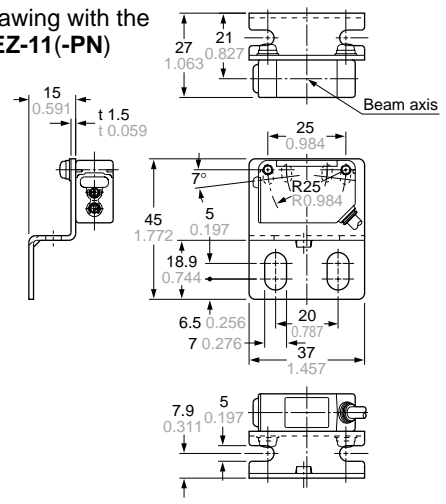

Metal-sheet
Double-feed Detection

GD

Hot Melt Glue Detection

TH

Wire Flaw Detection

LA-T

Water Detection

EZ-10

EZ-10

DIMENSIONS (Unit: mm in) The CAD data in the dimensions can be downloaded from the SUNX website: <http://www.sunx.co.jp/>

MS-CX-3 Sensor mounting bracket (Optional)

Assembly dimensions Mounting drawing with the receiver of EZ-11(-PN)

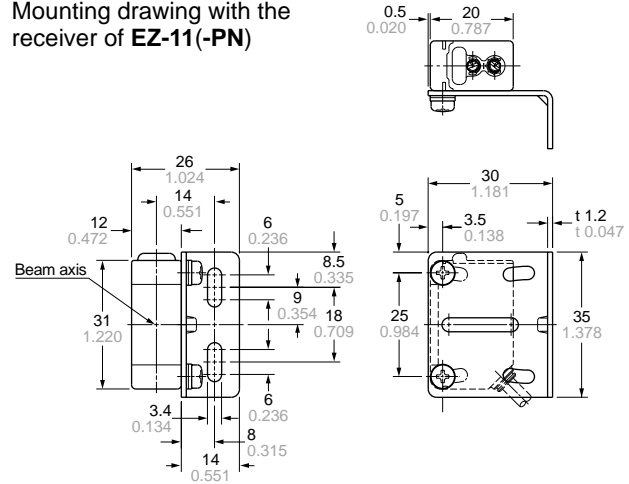
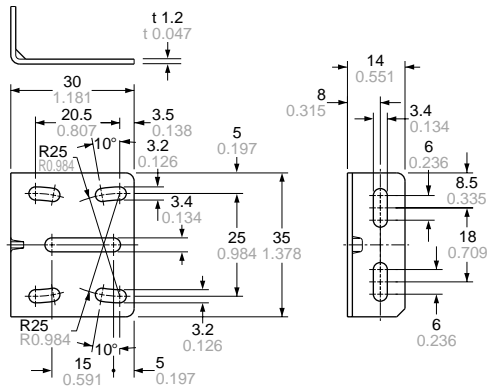

Material: Stainless steel (SUS304)
Two M3 (length 12 mm 0.472 in) screws with washers are attached.

MS-AJ1 Universal sensor mounting stand (Optional)

MS-AJ2 Universal sensor mounting stand (Optional)

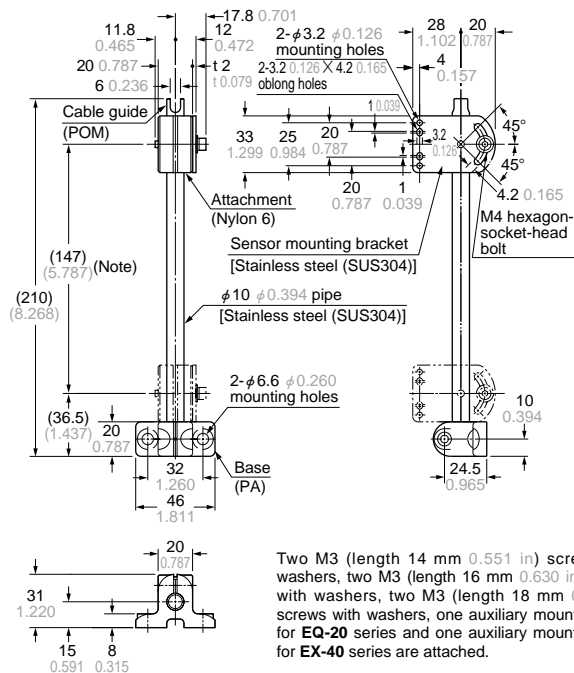
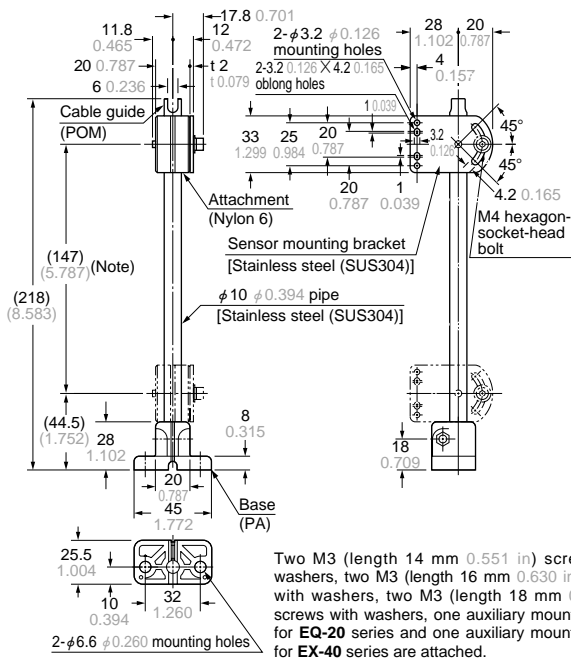

Two M3 (length 14 mm 0.551 in) screws with washers, two M3 (length 16 mm 0.630 in) screws with washers, two M3 (length 18 mm 0.709 in) screws with washers, one auxiliary mounting plate for EQ-20 series and one auxiliary mounting plate for EX-40 series are attached.

Two M3 (length 14 mm 0.551 in) screws with washers, two M3 (length 16 mm 0.630 in) screws with washers, two M3 (length 18 mm 0.709 in) screws with washers, one auxiliary mounting plate for EQ-20 series and one auxiliary mounting plate for EX-40 series are attached.

Note: The dimensions in the brackets indicate the adjustable range of the movable part.

Note: The dimensions in the brackets indicate the adjustable range of the movable part.

DIMENSIONS (Unit: mm in)

MS-AJ1 MS-AJ2

Universal sensor mounting stand (Optional)

Assembly dimensions (Mounting part only)

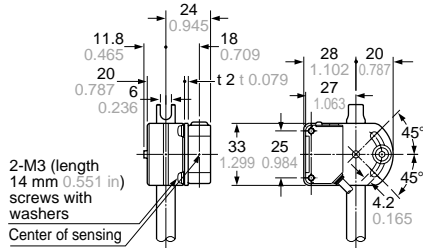

MS-AJ1-A

Universal sensor mounting stand (Optional)

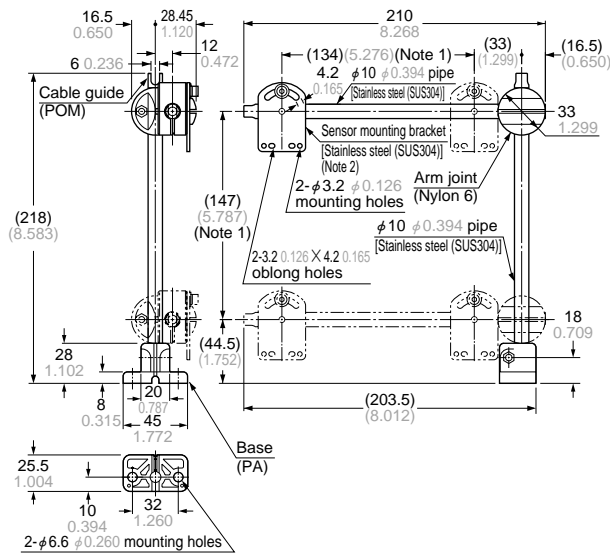

Two M3 (length 14 mm 0.551 in) screws with washers, two M3 (length 16 mm 0.630 in) screws with washers, two M3 (length 18 mm 0.709 in) screws with washers, one auxiliary mounting plate for EQ-20 series and one auxiliary mounting plate for EX-40 series are attached.

- Notes: 1) The dimensions in the brackets indicate the adjustable range of the movable part.
2) Refer to MS-AJ1/AJ2 for the assembly dimensions with sensor mounting bracket or sensor.

MS-AJ2-A

Universal sensor mounting stand (Optional)

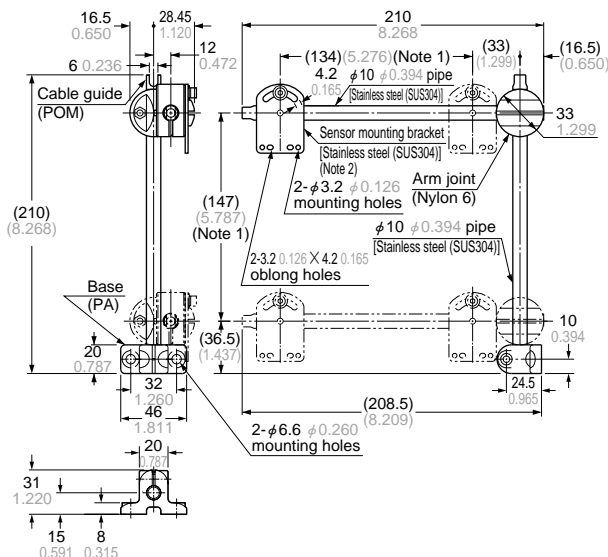

Two M3 (length 14 mm 0.551 in) screws with washers, two M3 (length 16 mm 0.630 in) screws with washers, two M3 (length 18 mm 0.709 in) screws with washers, one auxiliary mounting plate for EQ-20 series and one auxiliary mounting plate for EX-40 series are attached.

- Notes: 1) The dimensions in the brackets indicate the adjustable range of the movable part.
2) Refer to MS-AJ1/AJ2 for the assembly dimensions with sensor mounting bracket or sensor.

Metal-sheet
Double-feed Detection

GD

Hot Melt Glue Detection

TH

Wire Flaw Detection

LA-T

Water Detection

EZ-10