

# FX-13

## Slim Body High Speed Fiber Sensor

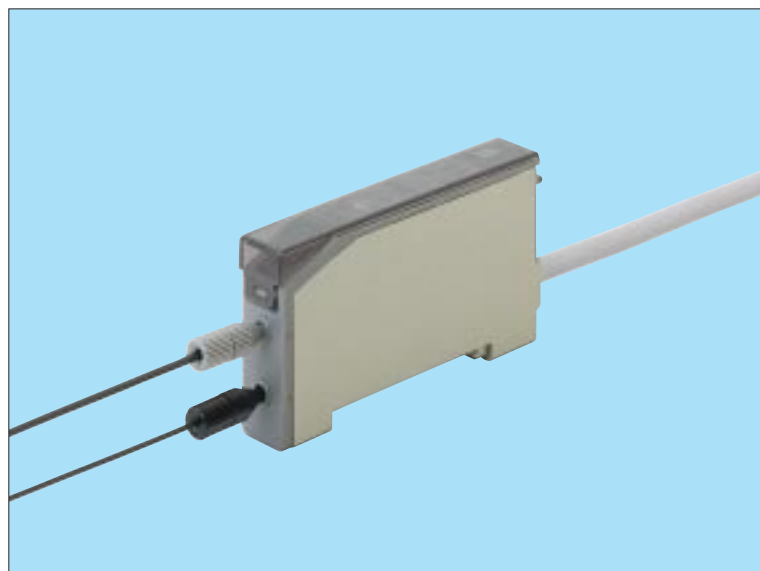

**Slim, Fast and Reliable**

**CE Marked**

Conforming to EMC Directive

### Ultra-high Speed Response Time: 30 $\mu$ s

The high-speed sensing amplifier FX-13 is quite immune to ambient light because of its modulated beam. Also, the response time is just 30  $\mu$ s. It can detect small and high-speed moving objects reliably.

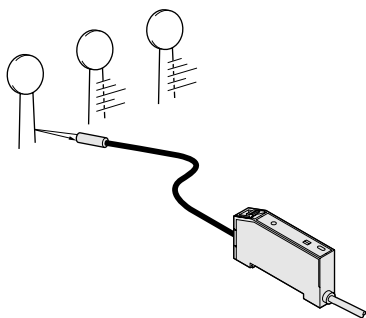

### 8-turn Adjuster with Indicator

The sensitivity is adjustable with an 8-turn potentiometer enabling delicate setting. Moreover, the potentiometer position can be confirmed at a glance on the indicator.

8-turn potentiometer with indicator

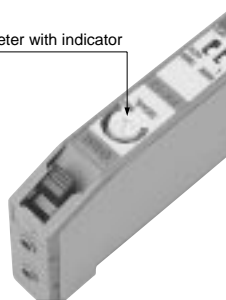

### Compact Size! 10mm Width

Since its width is merely 10mm, it can be installed in a narrow space.

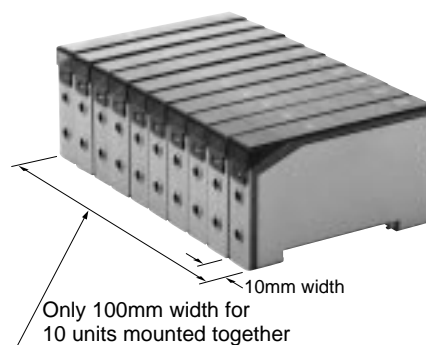

### OFF-delay Timer Function

FX-13 is incorporated with an approx. 40ms fixed OFF-delay timer.

The delay timer extends the output signal and is useful to detect small objects which travel so fast that the device connected to the sensor cannot respond.

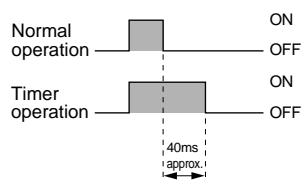

## APPLICATIONS

### Distinguishing top/bottom surface of a chip component

Due to the small spot size ( $\phi 0.3\text{mm}$ ), the top surface can be distinguished from the bottom surface for small components, such as the 1005 chip.

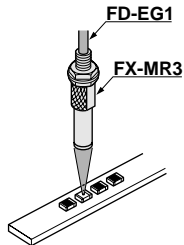

### Detecting presence/absence of wire

Even if the wire vibrates, its end can be reliably detected.

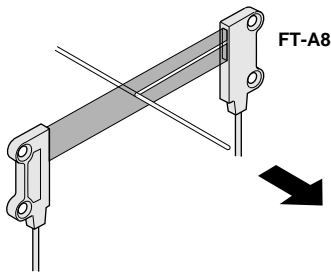

### Detecting bad mark on IC

The wide sensing area reduces the effect of characters printed on the IC.

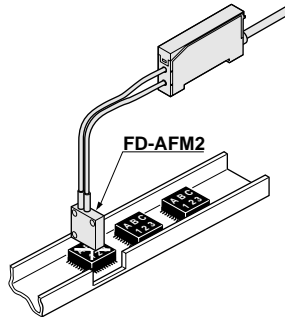

### Sensor wire-saving

When checking 16 points at a time, 16 Nos. of sensors are needed and the wiring could be complicated. But, if the optional sensor block is used, the wiring can be done easily.

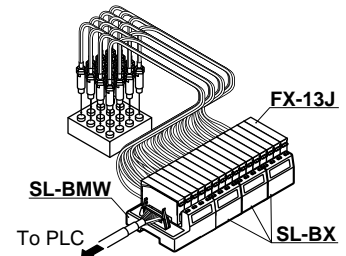

FX-D11/A1/M1

Fiber Sensors  
FX-13

FX-11A

FZ-10

CX-20

Amplifier Built-in Type  
CX-30

CX-R/M5/D100/ND300R

EX-10











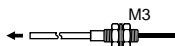

EX-20

# FX-13

## ORDER GUIDE

### General use fibers [Thru-beam type (one pair set)]



Type	Shape of fiber head (mm)	Sensing range (Note 1)	Min. sensing object [under the optimum condition (Note 2)]	Features	Fiber cable length	Model No.
Standard	Long sensing range Lens mountable 	150mm	φ0.15mm opaque object	• Twice the sensing range as before	Free Cut 2m	FT-B8
	With sleeve 	80mm	φ0.08mm opaque object	• Free-cut type	Free Cut 2m	FT-FM2 FT-FM2S With sleeve 90mm FT-FM2S4 With sleeve 40mm FT-SFM2
						
Small fiber head	Lens mountable 	80mm	φ0.08mm opaque object	• Miniature head but having the same sensing range as the standard type fiber	Free Cut 2m	FT-T80
Small diameter						FT-NFM2
	With sleeve 	25mm	φ0.05mm opaque object	• Suitable for detection in a congested equipment • Free-cut type	Free Cut 2m	FT-NFM2S With sleeve 90mm FT-NFM2S4 With sleeve 40mm FT-SNFM2
						
Sharp bend	Standard Lens mountable 	70mm	φ0.06mm opaque object	• The fiber can be bent sharply, like an electric wire, to avoid space wastage in installation because of its small allowable bending radius of R1mm or more.	Free Cut 2m	NEW FT-W8 NEW FT-WS8
						NEW FT-W4 NEW FT-WS4 NEW FT-WS8L
	Small diameter 	12mm	φ0.06mm opaque object			
Flexible	With lens 	210mm	φ0.016mm opaque object			
	Lens mountable 	80mm	φ0.12mm opaque object	• Allowable bending radius: R4mm or more • Bending durability: 1,000,000 times or more	Free Cut 2m	FT-P80
	Small diameter 	25mm	φ0.05mm opaque object			FT-P40
Small diameter 	30mm	φ0.05mm opaque object			1m	FT-P2











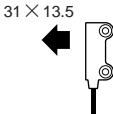

Notes: 1) Please take care that the sensing range of the free-cut type fiber may be reduced by 20% max. depending upon how the fiber is cut.

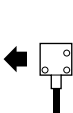
2) The optimum condition is the condition when the sensitivity is set so that the sensing output just changes to light incident operation in the object absent condition.

## ORDER GUIDE

### Special use fibers [Thru-beam type (one pair set)]



Type	Shape of fiber head (mm)	Sensing range (Note 1)	Min. sensing object [under the optimum condition (Note 2)]	Features	Fiber cable length	Model No.
Long sensing range with lens	 M14	3,500mm	φ 1mm opaque object	<ul style="list-style-type: none"> <li>Large lenses on the fiber heads increase the sensing range significantly.</li> <li>Fiber cable length 10m each</li> </ul>	Free Cut 10m	FT-FM10L
	 φ 2.5	200mm	φ 0.15mm opaque object	<ul style="list-style-type: none"> <li>Long sensing range with small fiber heads of φ 2.5mm</li> </ul>	Free Cut 2m	FT-SFM2L
Wide beam	 31 × 13.5	300mm	(Note 3)	<ul style="list-style-type: none"> <li>The wide beam detects an object at any place within the range.</li> </ul>	Free Cut 2m	<b>NEW</b> FT-A8
Array	Top sensing 	70mm	Horizontal φ 0.04mm opaque object Vertical φ 0.6mm opaque object	<ul style="list-style-type: none"> <li>The wide beam detects an object at any place within the range.</li> </ul>	Free Cut 2m	FT-AFM2
	Side sensing 	60mm	Horizontal φ 0.04mm opaque object Vertical φ 0.6mm opaque object			FT-AFM2E
Elbow	Lens mountable  M4	60mm	φ 0.12mm opaque object	<ul style="list-style-type: none"> <li>The fiber head is bent at a right angle with 5mm bending radius.</li> </ul>	Free Cut 2m	FT-R80
Side-view	Small diameter  φ 1	38mm	φ 0.08mm opaque object	<ul style="list-style-type: none"> <li>The side-view sensing enables it to be used in a small space.</li> </ul>	Free Cut 2m	FT-V22
	Sleeve part cannot be bent.  φ 2.5 (φ 2 for FT-V22)	15mm	φ 0.08mm opaque object			FT-V41
	 φ 1.5 φ 2.5	50mm	φ 0.08mm opaque object			FT-SFM2SV2
Ultra-small diameter	 φ 0.5 φ 3	6mm	φ 0.03mm opaque object	<ul style="list-style-type: none"> <li>Ultra-small diameter heads, very narrow beam φ 0.25mm</li> </ul>	1m	FT-E20
	Sleeve part cannot be bent.					
Narrow beam	 φ 3	125mm	φ 0.3mm opaque object	<ul style="list-style-type: none"> <li>Aperture angle 4° or less</li> <li>Laser beam equivalent detection</li> </ul>	1m	FT-K2
	 φ 4	80mm	φ 0.3mm opaque object	<ul style="list-style-type: none"> <li>Aperture angle 4° or less</li> <li>Side-view type</li> </ul>		FT-KV2
	 φ 1 M3	38mm	φ 0.05mm opaque object	<ul style="list-style-type: none"> <li>The narrow aperture angle, 1/6 of a conventional model, reduces interference.</li> </ul>		FT-KM1S2
	Sleeve part cannot be bent.					

Notes: 1) Please take care that the sensing range of the free-cut type fiber may be reduced by 20% max. depending upon how the fiber is cut.

**2) The optimum condition is the condition when the sensitivity is set so that the sensing output just changes to light incident operation in the object absent condition.**

3) The sensing width varies with the sensing object size and the sensing distance. Please contact our office for details.

FX-D11/A1/M1

Fiber Sensors  
FX-13

FX-11A

FZ-10

CX-20

CX-30

Amplifier Built-in Type  
CX-R/M5/D10/ND300R

EX-10

EX-20

# FX-13

## ORDER GUIDE

### Environment resistant fibers [Thru-beam type (one pair set)]



Type	Shape of fiber head (mm)	Sensing range (Note 1)	Min. sensing object [under the optimum condition (Note 2)]	Features	Fiber cable length	Model No.		
Heat-resistant	Lens mountable	70mm	φ 0.08mm opaque object	<ul style="list-style-type: none"> <li>Heat-resistant temp.: 350°C</li> <li>Cold-resistant temp.: -60°C</li> </ul>	2m	<b>FT-H35-M2</b>		
	With sleeve					<b>FT-H35-M2S6</b> With sleeve 60mm		
	Lens mountable	110mm			φ 0.15mm opaque object	<ul style="list-style-type: none"> <li>Flexible cable with silicone jacket</li> <li>Heat-resistant temp.: 200°C</li> <li>Cold-resistant temp.: -60°C</li> </ul>	1m	<b>FT-H20-M1</b>
	Lens mountable							Free Cut 2m
Chemical-resistant	φ 5.5	340mm	φ 0.5mm opaque object	<ul style="list-style-type: none"> <li>Usable in chemical solvents</li> <li>Heat-resistant specification (115°C)</li> <li>Long sensing range with lens</li> </ul>			2m (Bending R.: 30mm)	<b>FT-L8Y</b>
	φ 5.5	100mm	φ 0.5mm opaque object					<ul style="list-style-type: none"> <li>Usable in chemical solvents</li> <li>Heat-resistant specification (115°C)</li> <li>Side-view type</li> </ul>
Vacuum	Lens mountable	60mm	φ 0.1mm opaque object	<ul style="list-style-type: none"> <li>Usable in vacuum chamber</li> <li>Heat-resistant temp.: 120°C</li> </ul>	1m (Bending R.: 200mm)	<b>FT-6V</b>		
		30mm	φ 0.1mm opaque object			1m (Bending R.: 30mm)	<b>FT-60V</b>	

Notes: 1) Please take care that the sensing range of the free-cut type fiber may be reduced by 20% max. depending upon how the fiber is cut.

2) The optimum condition is the condition when the sensitivity is set so that the sensing output just changes to light incident operation in the object absent condition.

The vacuum type fiber must be used with the following products as a set.

FT-J6: Fiber at atmospheric side (one pair set)

FV-BR1: Photo-terminal (one pair set)

### Semi-standard fibers (Custom-order made)

The fiber cable length or sleeve length of the standard fibers can be modified at your request. Select the fiber cable length (symbol ) or the sleeve length (symbol ) from the table below.

Type	Basic model No.	Fiber cable length (Unit: m)	Sleeve length (Unit: cm)
Standard threaded head (free-cut)	<b>FT-FM</b>	3, 4, 5, 10, 15, 20, 25, 30	—
	<b>FT-FM</b> -S	2 (Note), 3, 4, 5, 10, 15, 20, 25, 30	1, 2, 3, 4, 5, 6, 7, 8, 9, 10, 11, 12
With large diameter lens	<b>FT-FM</b> L	20, 30	—
Small diameter threaded head with sleeve (free-cut)	<b>FT-NFM2-S</b>	—	1, 2, 3, 4, 5, 6, 7, 8, 9, 10, 11, 12
200°C heat-resistant	<b>FT-H20-M</b>	2, 3	—
350°C heat-resistant	<b>FT-H35-M</b>	3	—

Note: The standard fiber has a 2m fiber cable length and a 4cm or 9cm sleeve length.

### Correlation between sensing range attenuation coefficient and fiber cable length

Longer the fiber cable, shorter is the sensing range.

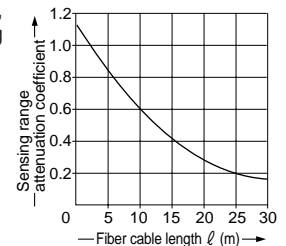

## ORDER GUIDE

### General use fibers [Reflective type]

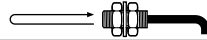

Type	Shape of fiber head (mm)	Sensing range (Note 1, 2)	Min. sensing object [at the maximum sensitivity (Note 3)]	Features	Fiber cable length	Model No.
Standard	Long sensing range	60mm	φ0.03mm gold wire	<ul style="list-style-type: none"> <li>Long sensing range</li> <li>Free-cut type</li> </ul>	Free Cut 2m	FD-B8
	Coaxial	30mm	φ0.02mm gold wire	<ul style="list-style-type: none"> <li>Suitable for green LED type</li> </ul>	500mm	FD-5
	With sleeve	φ2.5				<ul style="list-style-type: none"> <li>Free-cut type</li> </ul>
Small fiber head	30mm	φ0.02mm gold wire	<ul style="list-style-type: none"> <li>Miniature head but having the same sensing range as the standard type fiber</li> </ul>	Free Cut 2m	FD-T80	
	Small diameter  10mm	φ0.03mm gold wire			FD-T40	
	30mm	φ0.02mm gold wire			FD-S80	
Small diameter	10mm	φ0.03mm gold wire	<ul style="list-style-type: none"> <li>Suitable for detection in a congested equipment</li> <li>Free-cut type</li> </ul>	Free Cut 2m	FD-NFM2	
	With sleeve  φ1.48				FD-NFM2S <small>With sleeve 90mm</small> FD-NFM2S4 <small>With sleeve 40mm</small>	
	10mm	FD-SNFM2				
Sharp bend	Standard  15mm	φ0.01mm gold wire	<ul style="list-style-type: none"> <li>The fiber can be bent sharply, like an electric wire, to avoid space wastage in installation because of its small allowable bending radius of R1mm or more (FD-WG4, FD-WSG4: R2mm or more).</li> </ul>	Free Cut 2m	NEW FD-W8	
	Small head  15mm	φ0.01mm gold wire			NEW FD-WT8	
					NEW FD-WS8	
	High precision	Lens mountable  7mm			φ0.01mm gold wire	NEW FD-WG4
Coaxial  7mm		NEW FD-WSG4				
Flexible	25mm	φ0.03mm gold wire	<ul style="list-style-type: none"> <li>Allowable bending radius: R4mm or more</li> <li>Bending durability: 1,000,000 times or more</li> </ul>	Free Cut 2m	FD-P80	
	Small diameter  4mm	φ0.02mm gold wire			FD-P40	
	Small diameter  5mm	φ0.02mm gold wire			1m	FD-P2

Notes: 1) The sensing range is specified for white non-glossy paper [100 × 100mm (FD-B8: 200 × 200mm)] as the object.  
 2) Please take care that the sensing range of the free-cut type fiber may be reduced by 20% max. depending upon how the fiber is cut.

**3) The minimum sensing object is specified for maximum sensitivity. Also, note that the corresponding setting distance is different from the rated sensing distance.**

FX-D11/A1/M1

Fiber Sensors  
FX-13

FX-11A

FZ-10

CX-20

CX-30

Amplifier Built-in Type  
CX-R/M5/D10/ND300R

EX-10

EX-20

## ORDER GUIDE

## Special use fibers [Reflective type]

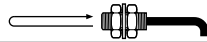





Type	Shape of fiber head (mm)	Sensing range (Note 1, 2)	Min. sensing object [at the maximum sensitivity (Note 3)]	Features	Fiber cable length	Model No.
Fixed-focus reflective	18 × 14	5 to 8mm (Convergent point: 6mm)	φ 0.02mm gold wire	• Detection is not affected by object color.	Free Cut 2m	FD-L4
High precision	Lens mountable Coaxial	12mm	φ 0.02mm gold wire	• Precise position sensing with coaxial fiber	Free Cut 2m	FD-G4
	Lens mountable Coaxial • small diameter	4mm	φ 0.02mm gold wire	• Combination with the FX-MR3 lens gives an extremely small spot diameter of φ 0.3mm approx.	500mm	FD-EG1
Array	Top sensing	26mm	Horizontal φ 0.01mm gold wire Vertical φ 0.2mm copper wire	• Its wide beam meets various needs.	Free Cut 2m	FD-AFM2
	Side sensing	26mm				FD-AFM2E
Elbow		20mm	φ 0.03mm gold wire	• The fiber head is bent at a right angle with 5mm bending radius at the neck.	Free Cut 2m	FD-R80
Side-view	Small diameter Sleeve part cannot be bent.	6mm	φ 0.2mm copper wire	• The side view sensing enables it to be used in a small space.	Free Cut 2m	FD-V41
	Sleeve part cannot be bent.	10mm	φ 0.3mm copper wire			FD-SFM2SV2
Ultra-small diameter	Coaxial Sleeve part cannot be bent.	4mm	φ 0.02mm gold wire	• Precise position sensing with coaxial fiber	1m	FD-ENM1S1
	Coaxial Sleeve part cannot be bent.	3mm	φ 0.02mm gold wire	• The narrow aperture angle, 1/6 of a conventional model, produces a small detecting area.	1m	FD-KM1S2

Notes: 1) The sensing range is specified for white non-glossy paper [100 × 100mm (FD-V41: 50 × 50mm, FD-KM1S2: 10 × 10mm)] as the object.  
2) Please take care that the sensing range of the free-cut type fiber may be reduced by 20% max. depending upon how the fiber is cut.

**3) The minimum sensing object is specified for maximum sensitivity. Also, note that the corresponding setting distance is different from the rated sensing distance.**

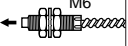
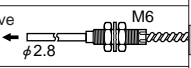
## ORDER GUIDE

### Environment resistant fibers [Reflective type]

Type	Shape of fiber head (mm)	Sensing range (Note 1, 2)	Min. sensing object [at the maximum sensitivity (Note 2)]	Features	Fiber cable length	Model No.	
Heat-resistant	Coaxial 	30mm	φ 0.02mm gold wire	<ul style="list-style-type: none"> <li>Heat-resistant temp.: 350°C</li> <li>Cold-resistant temp.: -60°C</li> </ul>	2m	FD-H35-M2	
	With sleeve 					FD-H35-M2S6 <small>With sleeve 60mm</small>	
	Coaxial 	36mm		φ 0.08mm copper wire	<ul style="list-style-type: none"> <li>Flexible cable with silicone jacket</li> <li>Heat-resistant temp.: 200°C</li> <li>Cold-resistant temp.: -60°C</li> </ul>	1m	FD-H20-M1
	Free-cut 						Free-cut 2m
Vacuum		18mm	φ 0.02mm gold wire	<ul style="list-style-type: none"> <li>Usable in vacuum chamber</li> <li>Heat-resistant temp.: 120°C</li> </ul>	1m	FD-6V	



Notes: 1) The sensing range is specified for white non-glossy paper (100 × 100mm) as the object.  
 2) Please take care that the sensing range of the free-cut type fiber may be reduced by 20% max. depending upon how the fiber is cut.









**3) The minimum sensing object is specified for maximum sensitivity. Also, note that the corresponding setting distance is different from the rated sensing range.**

### The vacuum type fiber must be used with the following products as a set.

FT-J6: Fiber at atmospheric side (one pair set)  
 FV-BR1: Photo-terminal (one pair set)

### Semi-standard fibers (Custom-order made)

The fiber cable length or sleeve length of the standard fibers can be modified at your request. Select the fiber cable length (symbol ) or the sleeve length (symbol ) from the table below.

Type	Basic model No.	 Fiber cable length (Unit: m)	 Sleeve length (Unit: cm)
Standard threaded head (free-cut)	FD-FM 	3, 4, 5, 10, 15, 20	—
	FD-FM  -S 	2 (Note), 3, 4, 5, 10, 15, 20	1, 2, 3, 4, 5, 6, 7, 8, 9, 10, 11, 12
Small diameter threaded head with sleeve (free-cut)	FD-NFM2-S 	—	1, 2, 3, 4, 5, 6, 7, 8, 9, 10, 11, 12
200°C heat-resistant	FD-H20-M 	2, 3	—
350°C heat-resistant	FD-H35-M 	3	—

Note: The standard fiber has a 2m fiber cable length and a 4cm or 9cm sleeve length.

### • Correlation between sensing range attenuation coefficient and fiber cable length

Longer the fiber cable, shorter is the sensing range.

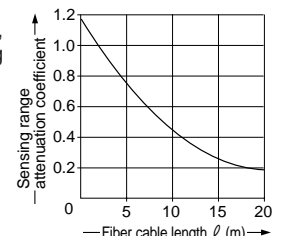

FX-D11/A1/M1

Fiber Sensors  
FX-13

FX-11A

FZ-10

CX-20

CX-30

Amplifier Built-in Type  
CX-R/M5/D10/ND300R

EX-10

EX-20

# FX-13

## ORDER GUIDE

### Amplifiers

Type	Appearance	Model No.	Output	Response time	Emitting element
High-speed		<b>FX-13</b>	NPN open-collector transistor	30 $\mu$ s or less	Red LED
		<b>FX-13P</b>	PNP open-collector transistor		

### Plug-in connector type

Plug-in connector type is available for the PNP output type.

When ordering the plug-in connector type, add suffix, 'J' to the model No.

Model No.: **FX-13PJ** (Standard: cable type)

Usable with the sensor block for simple wiring **SL-BMW** or **SL-BW**, or with the connector attached cable **CN-54-C2** or **CN-54-C5**.

### FX-13PJ

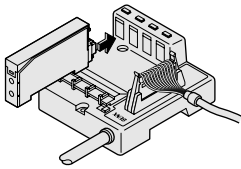

Sensor block for simple wiring  
**SL-BMW, SL-BW**

(Refer to P.54~ for details.)

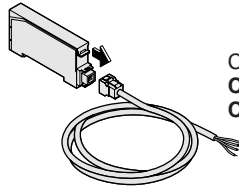

Connector attached cable  
**CN-54-C2** (2m long)  
**CN-54-C5** (5m long)

## OPTIONS

Designation	Model No.	Description		
Protective tube (For thru-beam type fiber)	<b>FTP-500</b> (0.5m)	For M4 thread	<b>FT-B8</b> <b>FT-P80</b> <b>FT-FM2</b> <b>FT-H13-FM2</b> <b>FT-FM2S</b> <b>FT-FM2S4</b>	
	<b>FTP-1000</b> (1m)		Applicable fibers	
	<b>FTP-1500</b> (1.5m)			The protective tube, made of non-corrosive stainless steel, protects the inner fiber cable from any external forces.
	<b>FTP-N500</b> (0.5m)	For M3 thread		
	<b>FTP-N1000</b> (1m)		For M6 thread	
	<b>FTP-N1500</b> (1.5m)	For M4 thread		<b>FD-T80</b> <b>FD-NFM2</b> <b>FD-NFM2S</b> <b>FD-NFM2S4</b>
Protective tube (For reflective type fiber)	<b>FDP-500</b> (0.5m)		For M6 thread	Applicable fibers
	<b>FDP-1000</b> (1m)			
	<b>FDP-1500</b> (1.5m)	For M4 thread		
	<b>FDP-N500</b> (0.5m)		Applicable fibers	
	<b>FDP-N1000</b> (1m)			<b>FD-T80</b> <b>FD-NFM2</b> <b>FD-NFM2S</b> <b>FD-NFM2S4</b>
<b>FDP-N1500</b> (1.5m)				
Fiber bender	<b>FB-1</b>	The fiber bender bends the sleeve part of the fiber head at the proper radius. (Note 1)		
Universal sensor mounting stand (Note 2)	<b>MS-AJ-F</b>	Mounting stand assembly for fiber (For M3, M4 or M6 threaded head fibers)		
Fiber cutter	<b>FX-CT1</b>	The free-cut type fiber can be easily cut.		

Notes: 1) Do not bend the sleeve part of any side-view type fiber, ultra-small diameter head type fiber, narrow beam type fiber, or narrow-view type fiber.

2) Refer to P.310~ for the universal sensor mounting stand.

### Protective tube



### Fiber bender

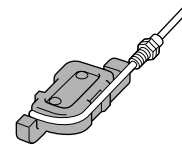

### Universal sensor mounting stand



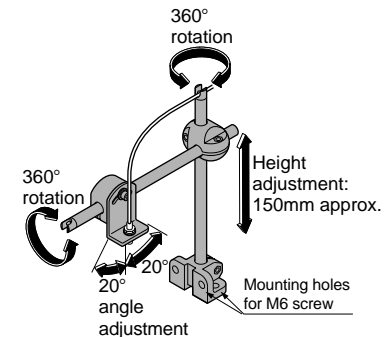

Using the arm which enables adjustment in the horizontal direction, sensing can also be done from above an assembly line.

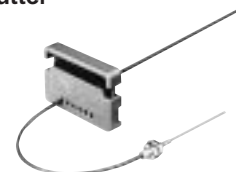

### Fiber cutter

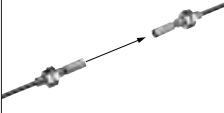
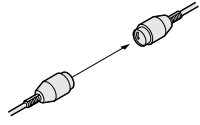

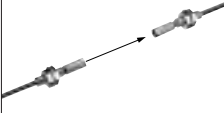
## OPTIONS

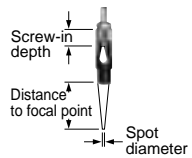
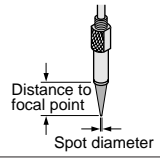
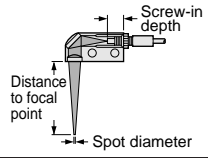
Designation	Model No.	Description																																				
For thru-beam type fiber	Expansion lens <b>FX-LE1</b>		Increases the sensing range by 5 times or more. • Ambient temperature: - 60 to + 350°C																																			
			<b>Sensing range (mm) [Lens on both sides]</b> <table border="1"> <thead> <tr> <th>Fiber</th> <th>Applicable amplifier</th> <th>FX-13□</th> </tr> </thead> <tbody> <tr><td>FT-B8</td><td></td><td>770</td></tr> <tr><td>FT-FM2</td><td></td><td>700</td></tr> <tr><td>FT-T80</td><td></td><td>700</td></tr> <tr><td>FT-W8</td><td></td><td>440</td></tr> <tr><td>FT-P80</td><td></td><td>700</td></tr> <tr><td>FT-H35-M2</td><td></td><td>560</td></tr> <tr><td>FT-H20-M1</td><td></td><td>560</td></tr> <tr><td>FT-R80</td><td></td><td>600</td></tr> </tbody> </table>	Fiber	Applicable amplifier	FX-13□	FT-B8		770	FT-FM2		700	FT-T80		700	FT-W8		440	FT-P80		700	FT-H35-M2		560	FT-H20-M1		560	FT-R80		600								
	Fiber	Applicable amplifier	FX-13□																																			
	FT-B8		770																																			
	FT-FM2		700																																			
FT-T80		700																																				
FT-W8		440																																				
FT-P80		700																																				
FT-H35-M2		560																																				
FT-H20-M1		560																																				
FT-R80		600																																				
Super-expansion lens <b>FX-LE2</b>		Tremendously increases the sensing range with large aperture lenses. • Ambient temperature: - 60 to + 350°C																																				
		<b>Sensing range (mm) [Lens on both sides]</b> <table border="1"> <thead> <tr> <th>Fiber</th> <th>Applicable amplifier</th> <th>FX-13□</th> </tr> </thead> <tbody> <tr><td>FT-B8</td><td></td><td>3,500 (Note)</td></tr> <tr><td>FT-FM2</td><td></td><td>3,500 (Note)</td></tr> <tr><td>FT-W8</td><td></td><td>3,500 (Note)</td></tr> <tr><td>FT-P80</td><td></td><td>3,500 (Note)</td></tr> <tr><td>FT-H35-M2</td><td></td><td>3,500 (Note)</td></tr> <tr><td>FT-H20-M1</td><td></td><td>1,600 (Note)</td></tr> <tr><td>FT-H13-FM2</td><td></td><td>3,000</td></tr> <tr><td>FT-R80</td><td></td><td>3,000</td></tr> </tbody> </table>	Fiber	Applicable amplifier	FX-13□	FT-B8		3,500 (Note)	FT-FM2		3,500 (Note)	FT-W8		3,500 (Note)	FT-P80		3,500 (Note)	FT-H35-M2		3,500 (Note)	FT-H20-M1		1,600 (Note)	FT-H13-FM2		3,000	FT-R80		3,000									
Fiber	Applicable amplifier	FX-13□																																				
FT-B8		3,500 (Note)																																				
FT-FM2		3,500 (Note)																																				
FT-W8		3,500 (Note)																																				
FT-P80		3,500 (Note)																																				
FT-H35-M2		3,500 (Note)																																				
FT-H20-M1		1,600 (Note)																																				
FT-H13-FM2		3,000																																				
FT-R80		3,000																																				
Side-view lens <b>FX-SV1</b>		Beam axis is bent by 90°. • Ambient temperature: - 60 to + 300°C																																				
		<b>Sensing range (mm) [Lens on both sides]</b> <table border="1"> <thead> <tr> <th>Fiber</th> <th>Applicable amplifier</th> <th>FX-13□</th> </tr> </thead> <tbody> <tr><td>FT-B8</td><td></td><td>180</td></tr> <tr><td>FT-FM2</td><td></td><td>150</td></tr> <tr><td>FT-T80</td><td></td><td>150</td></tr> <tr><td>FT-W8</td><td></td><td>90</td></tr> <tr><td>FT-P80</td><td></td><td>150</td></tr> <tr><td>FT-H35-M2</td><td></td><td>120</td></tr> <tr><td>FT-H20-M1</td><td></td><td>120</td></tr> </tbody> </table>	Fiber	Applicable amplifier	FX-13□	FT-B8		180	FT-FM2		150	FT-T80		150	FT-W8		90	FT-P80		150	FT-H35-M2		120	FT-H20-M1		120												
Fiber	Applicable amplifier	FX-13□																																				
FT-B8		180																																				
FT-FM2		150																																				
FT-T80		150																																				
FT-W8		90																																				
FT-P80		150																																				
FT-H35-M2		120																																				
FT-H20-M1		120																																				
Expansion lens for vacuum fiber <b>FV-LE1</b>		Sensing range increases by 7 times or more. • Ambient temperature: - 40 to + 120°C																																				
		<b>Sensing range (mm) [Lens on both sides]</b> <table border="1"> <thead> <tr> <th>Fiber</th> <th>Applicable amplifier</th> <th>FX-13□</th> </tr> </thead> <tbody> <tr><td>FT-6V</td><td></td><td>500</td></tr> <tr><td>FT-60V</td><td></td><td>250</td></tr> </tbody> </table>	Fiber	Applicable amplifier	FX-13□	FT-6V		500	FT-60V		250																											
Fiber	Applicable amplifier	FX-13□																																				
FT-6V		500																																				
FT-60V		250																																				
For reflective type fiber	Pinpoint spot lens <b>FX-MR1</b>		Pinpoint spot of $\phi 0.5\text{mm}$ . Enables detection of minute objects or small marks. • Distance to focal point: $6 \pm 1\text{mm}$ • Applicable fibers: <b>FD-WG4, FD-G4</b> • Ambient temperature: - 10 to + 300°C																																			
	Zoom lens <b>FX-MR2</b>	 Screw-in depth Distance to focal point Spot diameter	The spot diameter is adjustable from $\phi 0.7$ to $\phi 2\text{mm}$ according to how much the fiber is screwed in. • Applicable fiber: <b>FD-G4</b> • Ambient temperature: - 40 to + 70°C																																			
	Finest spot lens <b>FX-MR3</b>	 Distance to focal point Spot diameter	Extremely fine spot of $\phi 0.3\text{mm}$ achieved. • Applicable fibers: <b>FD-WG4, FD-EG1, FD-G4</b> • Ambient temperature: - 40 to + 70°C																																			
	Zoom lens (Side-view) type <b>FX-MR5</b>	 Screw-in depth Distance to focal point Spot diameter	<b>FX-MR2</b> is converted into a side-view type and can be mounted in a very small space. • Applicable fiber: <b>FD-G4</b> • Ambient temperature: - 40 to + 70°C																																			
			<table border="1"> <thead> <tr> <th>Screw-in depth</th> <th>Distance to focal point</th> <th>Spot diameter</th> </tr> </thead> <tbody> <tr><td>7mm</td><td>18.5mm approx.</td><td><math>\phi 0.7\text{mm}</math></td></tr> <tr><td>12mm</td><td>27mm approx.</td><td><math>\phi 1.2\text{mm}</math></td></tr> <tr><td>14mm</td><td>43mm approx.</td><td><math>\phi 2.0\text{mm}</math></td></tr> </tbody> </table> <table border="1"> <thead> <tr> <th>Screw-in depth</th> <th>Distance to focal point</th> <th>Spot diameter</th> </tr> </thead> <tbody> <tr><td><b>FD-WG4</b></td><td><math>7.5 \pm 0.5\text{mm}</math></td><td><math>\phi 0.5\text{mm}</math> approx.</td></tr> <tr><td><b>FD-EG1</b></td><td><math>7.5 \pm 0.5\text{mm}</math></td><td><math>\phi 0.3\text{mm}</math> approx.</td></tr> <tr><td><b>FD-G4</b></td><td><math>7.5 \pm 0.5\text{mm}</math></td><td><math>\phi 0.5\text{mm}</math> approx.</td></tr> </tbody> </table> <table border="1"> <thead> <tr> <th>Screw-in depth</th> <th>Distance to focal point</th> <th>Spot diameter</th> </tr> </thead> <tbody> <tr><td>8mm</td><td>13mm approx.</td><td><math>\phi 0.5\text{mm}</math></td></tr> <tr><td>10mm</td><td>15mm approx.</td><td><math>\phi 0.8\text{mm}</math></td></tr> <tr><td>14mm</td><td>30mm approx.</td><td><math>\phi 3.0\text{mm}</math></td></tr> </tbody> </table>	Screw-in depth	Distance to focal point	Spot diameter	7mm	18.5mm approx.	$\phi 0.7\text{mm}$	12mm	27mm approx.	$\phi 1.2\text{mm}$	14mm	43mm approx.	$\phi 2.0\text{mm}$	Screw-in depth	Distance to focal point	Spot diameter	<b>FD-WG4</b>	$7.5 \pm 0.5\text{mm}$	$\phi 0.5\text{mm}$ approx.	<b>FD-EG1</b>	$7.5 \pm 0.5\text{mm}$	$\phi 0.3\text{mm}$ approx.	<b>FD-G4</b>	$7.5 \pm 0.5\text{mm}$	$\phi 0.5\text{mm}$ approx.	Screw-in depth	Distance to focal point	Spot diameter	8mm	13mm approx.	$\phi 0.5\text{mm}$	10mm	15mm approx.	$\phi 0.8\text{mm}$	14mm	30mm approx.
Screw-in depth	Distance to focal point	Spot diameter																																				
7mm	18.5mm approx.	$\phi 0.7\text{mm}$																																				
12mm	27mm approx.	$\phi 1.2\text{mm}$																																				
14mm	43mm approx.	$\phi 2.0\text{mm}$																																				
Screw-in depth	Distance to focal point	Spot diameter																																				
<b>FD-WG4</b>	$7.5 \pm 0.5\text{mm}$	$\phi 0.5\text{mm}$ approx.																																				
<b>FD-EG1</b>	$7.5 \pm 0.5\text{mm}$	$\phi 0.3\text{mm}$ approx.																																				
<b>FD-G4</b>	$7.5 \pm 0.5\text{mm}$	$\phi 0.5\text{mm}$ approx.																																				
Screw-in depth	Distance to focal point	Spot diameter																																				
8mm	13mm approx.	$\phi 0.5\text{mm}$																																				
10mm	15mm approx.	$\phi 0.8\text{mm}$																																				
14mm	30mm approx.	$\phi 3.0\text{mm}$																																				

Note: The fiber cable length practically limits the sensing range to 3,500mm long (FT-H20-M1: 1,600mm).

# FX-13

## SPECIFICATIONS

### Fibers

Item	Type	Standard, small fiber head, small diameter, sharp bend, flexible, long sensing range with lens, wide beam, array, elbow, high precision, thru-beam type of ultra-small diameter	Fixed-focus reflective	Side-view, narrow beam, narrow-view, reflective type of ultra-small diameter
Allowable bending radius		R25mm or more (Sharp bend: R1mm or more (FD-WG4, FD-WSG4: R2mm or more) Flexible: R4mm or more, Thru-beam type of ultra-small diameter: R5mm or more)	R10mm or more	R25mm or more (FT-K2 and FT-KV2: R10mm or more)
Ambient temperature		-40 to +70°C (Sharp bend: -40 to +60°C, FD-EG1: -20 to +60°C)	-40 to +70°C	-20 to +60°C (FT-V41, FD-V41, FT-K2 and FT-KV2: -40 to +60°C)
Ambient humidity		35 to 85% RH (No dew condensation or icing allowed)		
Material	Fiber core	Acrylic		
	Sheath	Polyethylene (Thru-beam type of ultra-small diameter and flexible, except for FD-P2: Vinyl chloride) Reflective type of narrow-view: Polyurethane		
	Fiber head	Brass (Nickel plated): Threaded part of standard, threaded part of small diameter, threaded type of sharp bend, threaded part of thru-beam type ultra-small diameter, FT-P80, FD-P80, high precision, array, threaded part of FT-R80  Polycarbonate : FT-A8, lens of FT-WS8L  Stainless steel (SUS): FT-SFM2, small fiber head, non-threaded type of sharp bend, FT-SNFM2, FD-SNFM2, FT-SFM2L, FT-P40, FT-P2, FD-P40, FD-P2, sleeve part of sleeve-attached fiber  Polyolefin : Lens of FT-A8 ABS : FT-FM10L Acrylic : Lens of FT-FM10L Die-cast zinc alloy : Threaded part of FD-R80	ABS: FD-L4  Acrylic: Lens of FD-L4	Stainless steel (SUS) (FT-KV2, threaded part of FD-EN500S1-FD-ENM1S1-FT-KM1S2 and FD-KM1S2: Brass, Lens of FT-K2: Glass, Prism of FT-KV2: Acrylic)
Accessories	Threaded head fiber: 2 Nos. of nuts (thru-beam type: 4 Nos.) and 1 No. of toothed lock washer (thru-beam type: 2 Nos.) Free-cut type fiber: 1 No. of FX-CT1 (Fiber cutter) Small diameter free-cut type fiber, high precision free-cut type fiber: FX-AT10 ( $\phi$ 1mm fiber attachment) FX-AT13 ( $\phi$ 1.3mm fiber attachment) FT-WS4, FD-WT8, FD-WS8, FD-WG4 or FD-WSG4: FX-AT10 ( $\phi$ 1mm fiber attachment) FT-A8: 2 Nos. of 0.5 × 12mm seal type slit mask and 2 Nos. of 1 × 12mm seal type slit mask FD-L4: FX-AT10 ( $\phi$ 1mm fiber attachment), FX-AT13 ( $\phi$ 1.3mm fiber attachment), 2 Nos. of M2.6 (length 12mm) screws with washers and 2 Nos. of nuts			

### Fibers

Item	Type	Vacuum	Heat-resistant			Chemical-resistant
			350°C type	200°C type	130°C type	
Allowable bending radius		R200mm or more (FT-60V: R30mm or more)	R25mm or more			R30mm or more
Ambient temperature		-40 to +120°C	-60 to +350°C (Note 1, 2)	-60 to +200°C (Note 2)	-60 to +130°C	-40 to +115°C
Ambient humidity		35 to 85% RH (No dew condensation or icing allowed)				
Material	Fiber core	Quartz glass (Note 3)	Multi-component glass (Note 4)		Acrylic	
	Sheath	Fluorine resin	Stainless steel (SUS)	Silicone (Inside stainless steel (SUS) spiral tube)	Fluorine resin	Protective tube: Fluorine resin Fiber sheath: Polypropylene
	Fiber head	Aluminum		Brass (Nickel plated)	Brass (Nickel plated)	
Accessories	Threaded head fiber: 2 Nos. of nuts (thru-beam type: 4 Nos.) and 1 No. of toothed lock washer (thru-beam type: 2 Nos.) Free-cut type fiber, chemical-resistant type fiber: 1 No. of FX-CT1 (Fiber cutter)					

- Notes: 1) If the fiber is used under -30°C, its resistible maximum temperature drops to +200°C. If the side-view lens FX-SV1 is put on the fiber head, the allowable maximum temperature comes down to +300°C. (The ambient temperature range of the FX-SV1 is from -60 to +300°C.)  
 2) The ambient temperature of heat-resistant 350°C type and 200°C type fibers is the valve in dry condition. In humid environment, the ambient temperature differs. (For a high humidity of 85% RH, the ambient temperature is 0 to 40°C.)  
 3) If the fiber material is quartz glass, keep it away from vibration or impact.  
 4) If the fiber material is multi-component glass, keep it away from vibration or impact.

## SPECIFICATIONS

### Amplifiers

		Type	NPN output	PNP output
Item	Model No.		FX-13	FX-13P
Supply voltage			12 to 24V DC $\pm$ 10% Ripple P-P 10% or less	
Current consumption			35mA or less	
Sensing output			NPN open-collector transistor • Maximum sink current: 100mA • Applied voltage: 30V DC or less (between sensing output and 0V) • Residual voltage: 1.5V or less (at 100mA sink current) 0.4V or less (at 16mA sink current)	PNP open-collector transistor • Maximum source current: 100mA • Applied voltage: 30V DC or less (between sensing output and +V) • Residual voltage: 1.5V or less (at 100mA source current) 0.4V or less (at 16mA source current)
	Utilization category		DC-12 or DC-13	
	Output operation		Switchable either Light-ON or Dark-ON	
	Short-circuit protection		Incorporated	
Self-diagnosis output			NPN open-collector transistor • Maximum sink current: 50mA • Applied voltage: 30V DC or less (between self-diagnosis output and 0V) • Residual voltage: 1V or less (at 50mA sink current) 0.4V or less (at 16mA sink current)	PNP open-collector transistor • Maximum source current: 50mA • Applied voltage: 30V DC or less (between self-diagnosis output and +V) • Residual voltage: 1V or less (at 50mA source current) 0.4V or less (at 16mA source current)
	Output operation		ON in unstable sensing condition	
	Short-circuit protection		—————	
Response time			30 $\mu$ s or less	
Operation indicator			Red LED (lights up when the sensing output is ON)	
Stability indicator			Green LED (lights up under stable light received condition or stable dark condition)	
Sensitivity adjuster			8-turn potentiometer with indicator	
Timer function			Incorporated with approx. 40ms fixed OFF-delay timer, switchable either effective or ineffective	
Environmental resistance	Pollution degree		3 (Industrial environment)	
	Ambient temperature		- 10 to + 55°C (No dew condensation or icing allowed), Storage: - 20 to + 70°C	
	Ambient humidity		35 to 85% RH, Storage: 35 to 85% RH	
	Ambient illuminance		Sunlight: 10,000 lx at the light-receiving face, Incandescent light: 3,500 lx at the light-receiving face	
	EMC		Emission: EN50081-2, Immunity: EN50082-2	
	Voltage withstandability		1,000V AC for one min. between all supply terminals connected together and enclosure (Note)	
	Insulation resistance		20M $\Omega$ , or more, with 250V DC megger between all supply terminals connected together and enclosure (Note)	
	Shock resistance		10 to 150Hz frequency, 0.75mm amplitude in X, Y and Z directions for two hours each	
Emitting element			Red LED (modulated)	
Material			Enclosure: Heat-resistant ABS, Case cover: Polycarbonate, Fiber lock lever: PES	
Cable			0.2mm <sup>2</sup> 4-core cabtyre cable, 2m long	
Cable extension			Extension up to total 100m is possible with 0.3mm <sup>2</sup> , or more, cable.	
Weight			60g approx.	
Accessories			<b>MS-DIN-2</b> (Amplifier mounting bracket): 1 No., Adjusting screwdriver: 1 No.	

Note: The voltage withstandability and the insulation resistance values given in the above table are for the amplifier only.

# FX-13

## I/O CIRCUIT AND WIRING DIAGRAMS

### NPN output type

#### I/O circuit diagram

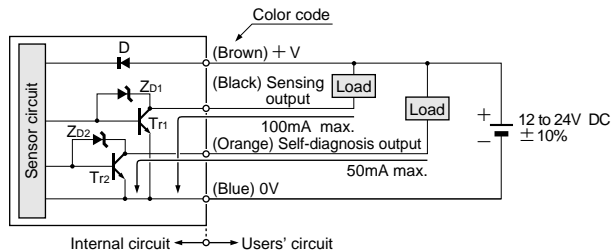

#### Wiring diagram

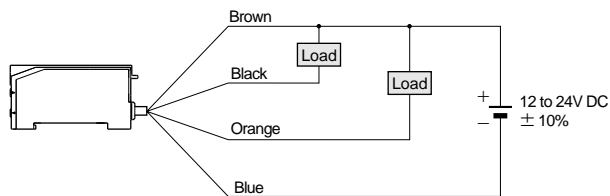

Symbols ... D: Reverse supply polarity protection diode  
 ZD1, ZD2: Surge absorption zener diode  
 Tr1, Tr2 : NPN output transistor

### PNP output type

#### I/O circuit diagram

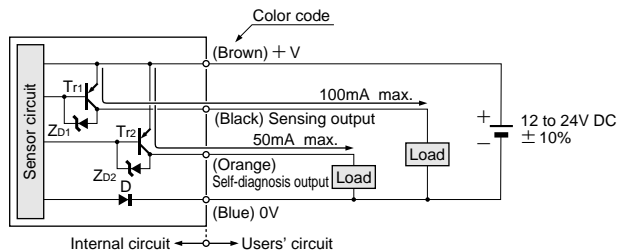

#### Wiring diagram

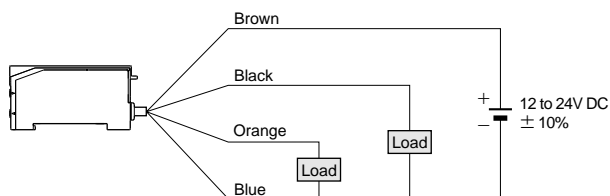

Symbols ... D: Reverse supply polarity protection diode  
 ZD1, ZD2: Surge absorption zener diode  
 Tr1, Tr2 : PNP output transistor

## SENSING CHARACTERISTICS (TYPICAL)

### Correlation between setting distance and excess gain

#### FT-FM2

Thru-beam type

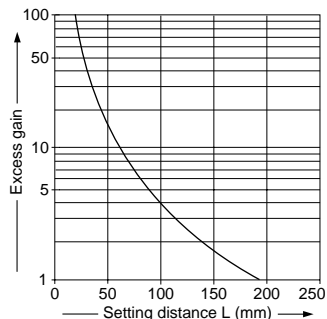

#### FD-FM2

Reflective type

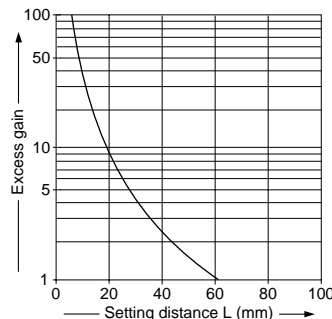

## SENSING CHARACTERISTICS (TYPICAL)

### Parallel deviation

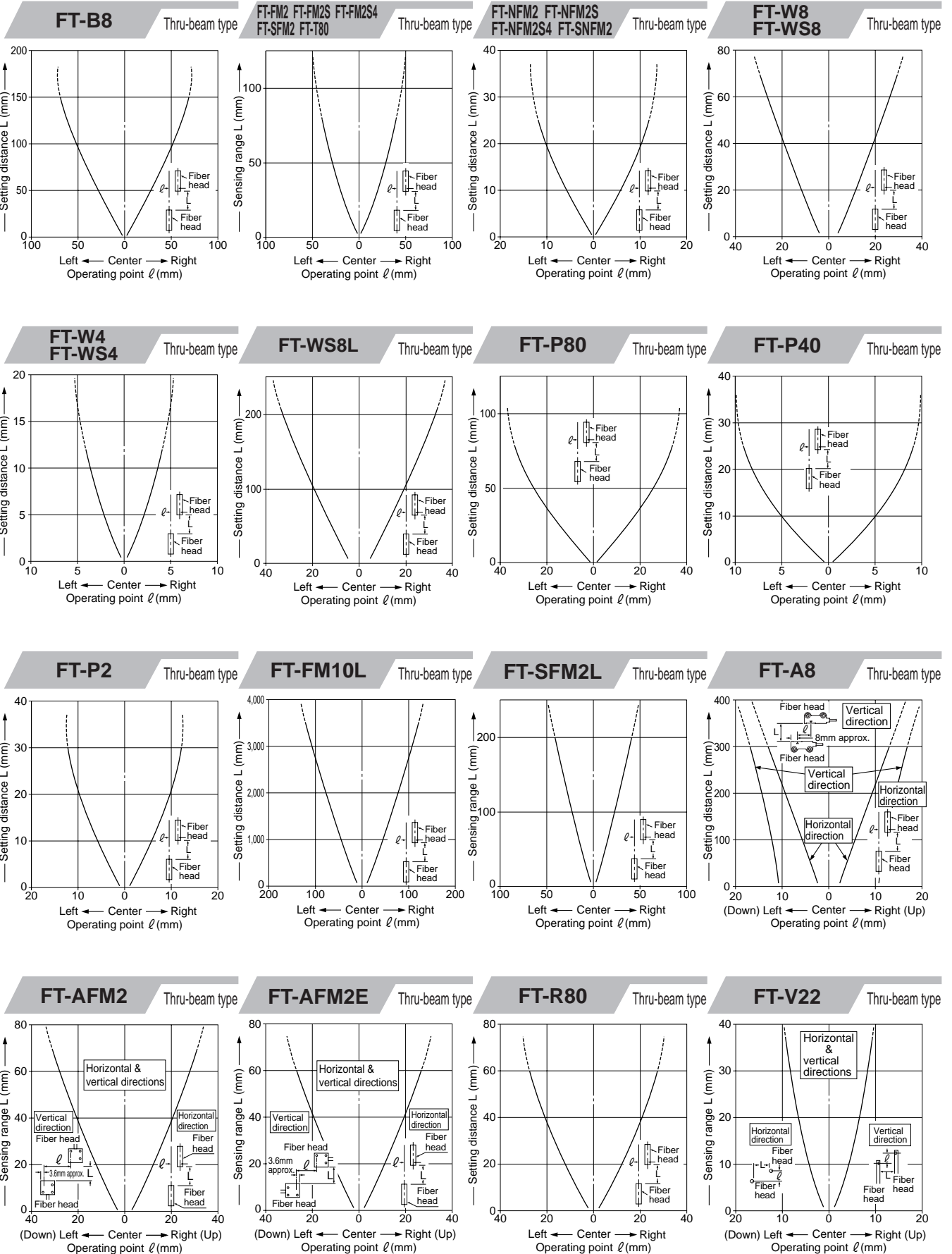

# FX-13

## SENSING CHARACTERISTICS (TYPICAL)

### Parallel deviation

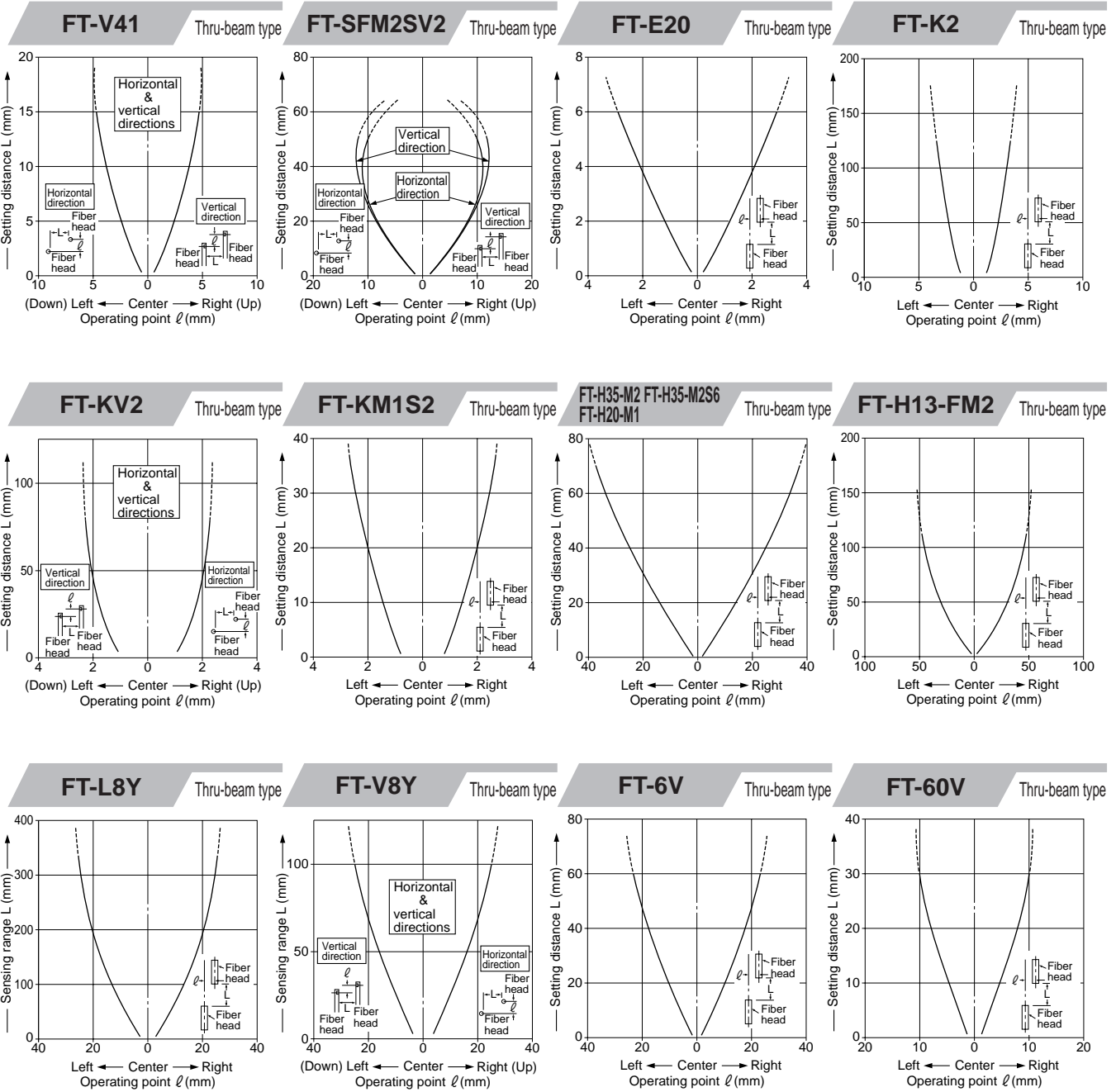

## SENSING CHARACTERISTICS (TYPICAL)

### Parallel deviation with FX-LE1 (expansion lens) applied on both sides

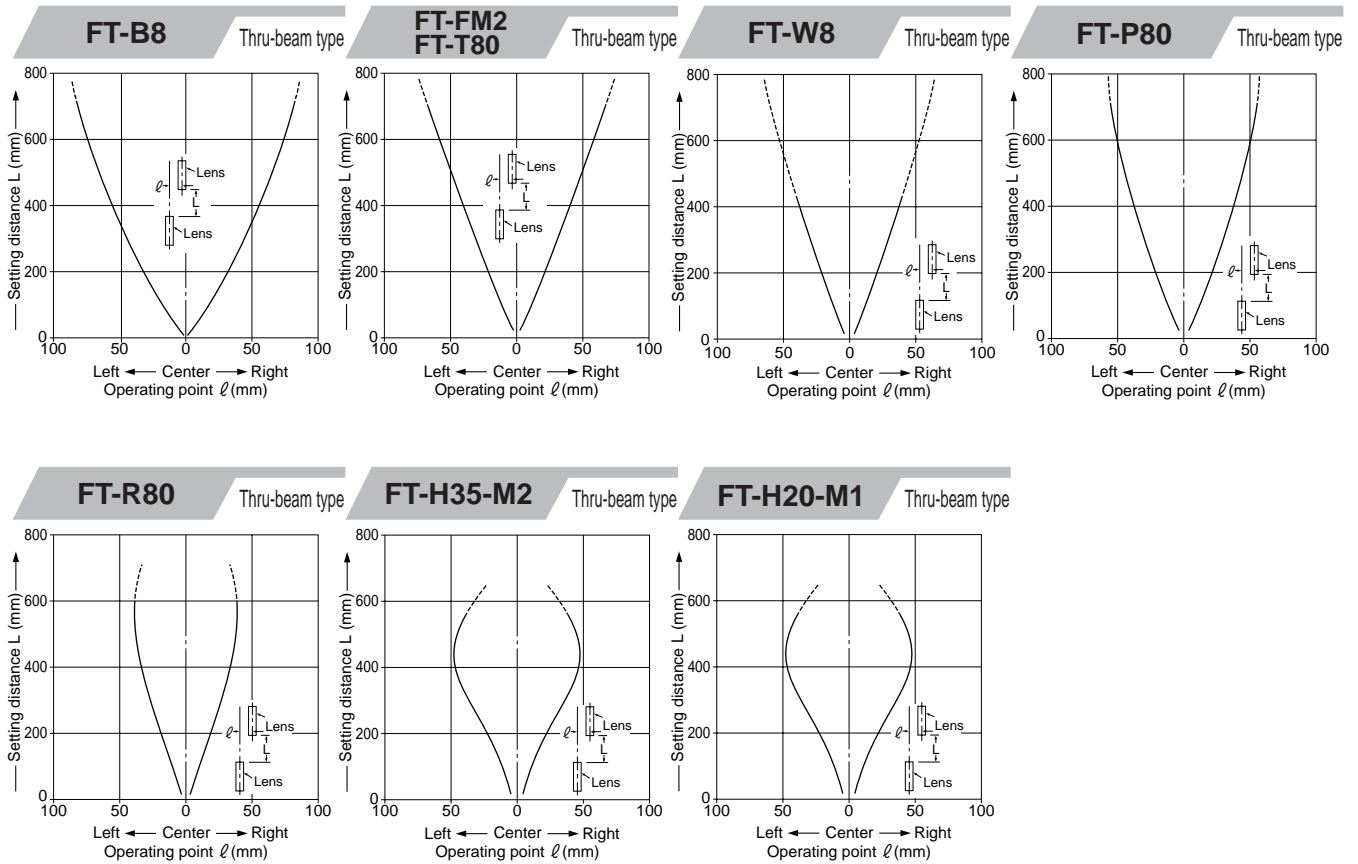

### Parallel deviation with FX-LE2 (super-expansion lens) applied on both sides

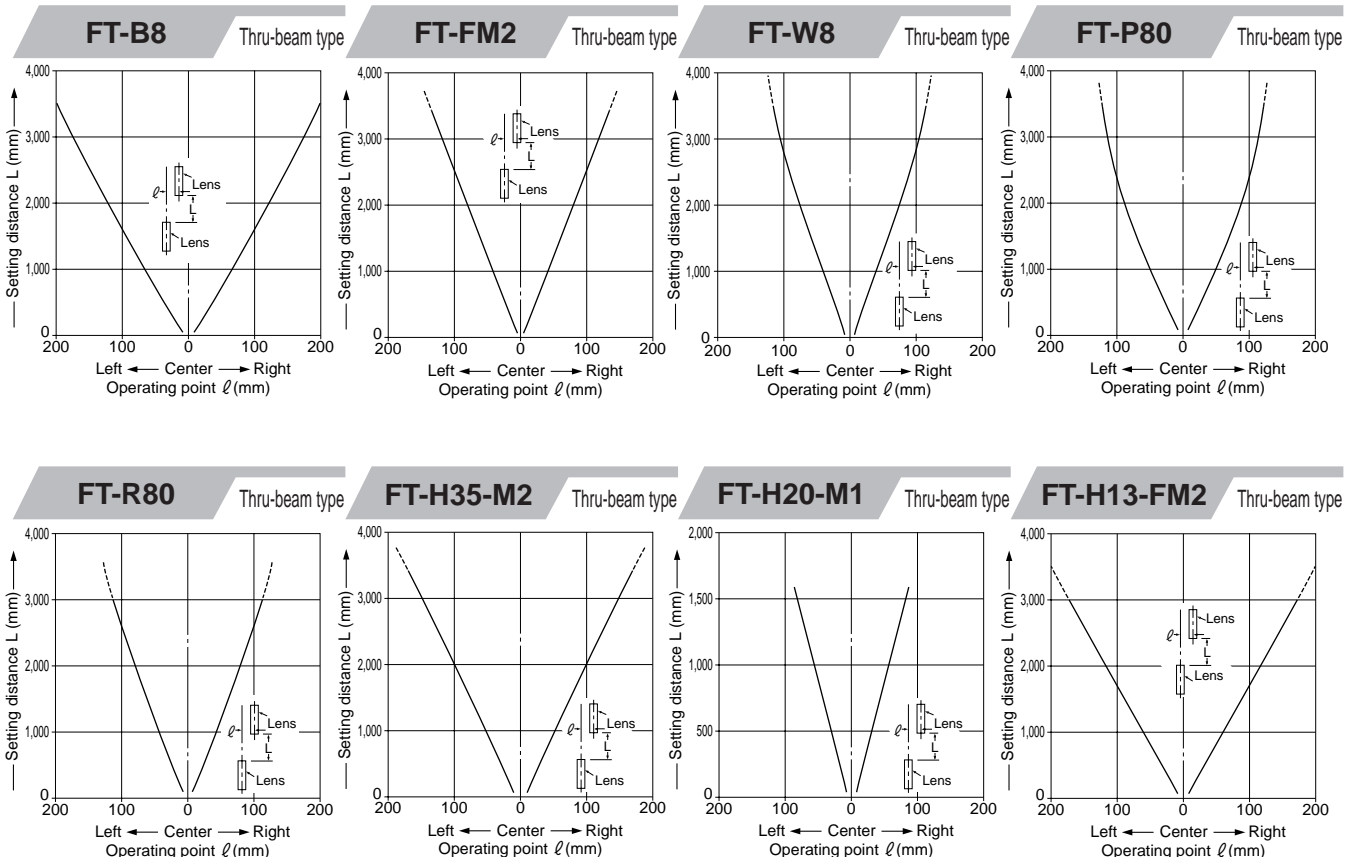

# FX-13

## SENSING CHARACTERISTICS (TYPICAL)

Parallel deviation with FX-SV1 (side-view lens) applied on both sides

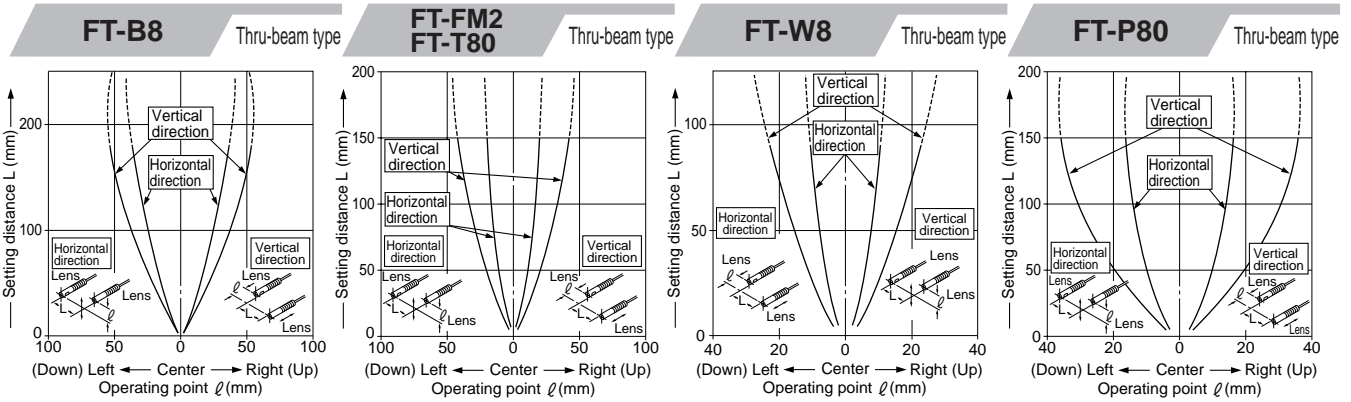

**FT-H35-M2** Thru-beam type  
**FT-H20-M1** Thru-beam type

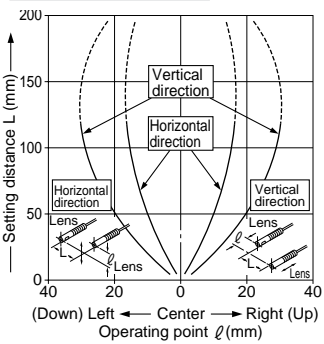

Parallel deviation with FV-LE1 (vacuum-expansion lens) applied on both sides

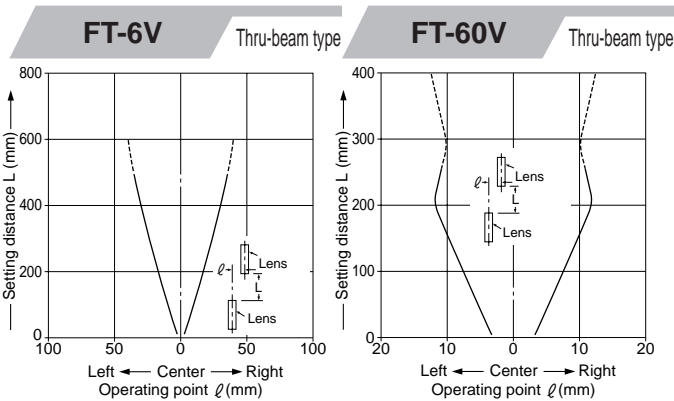

Parallel deviation with seal type slit masks

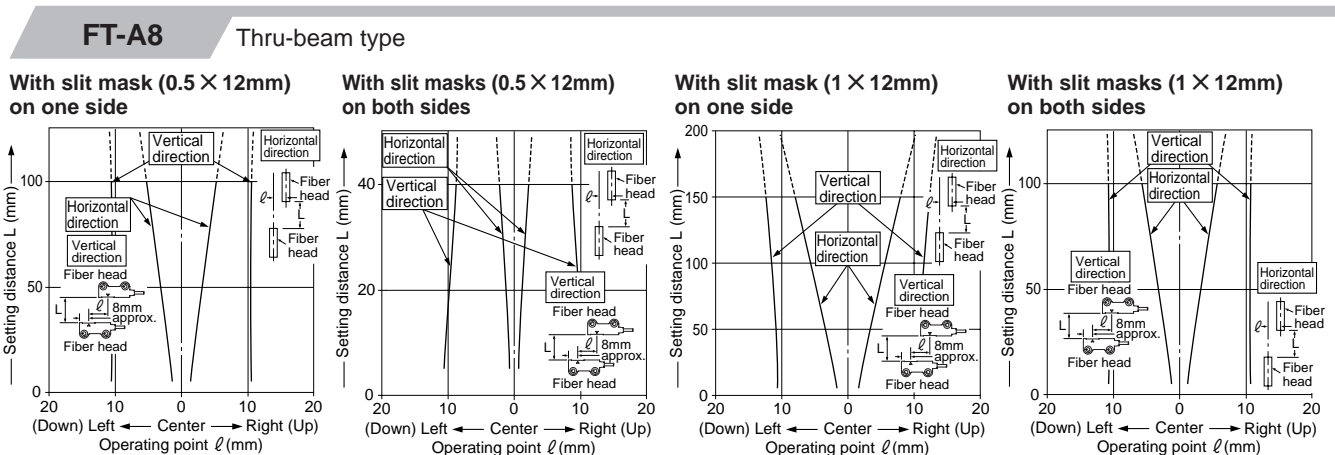

## SENSING CHARACTERISTICS (TYPICAL)

### Sensing fields

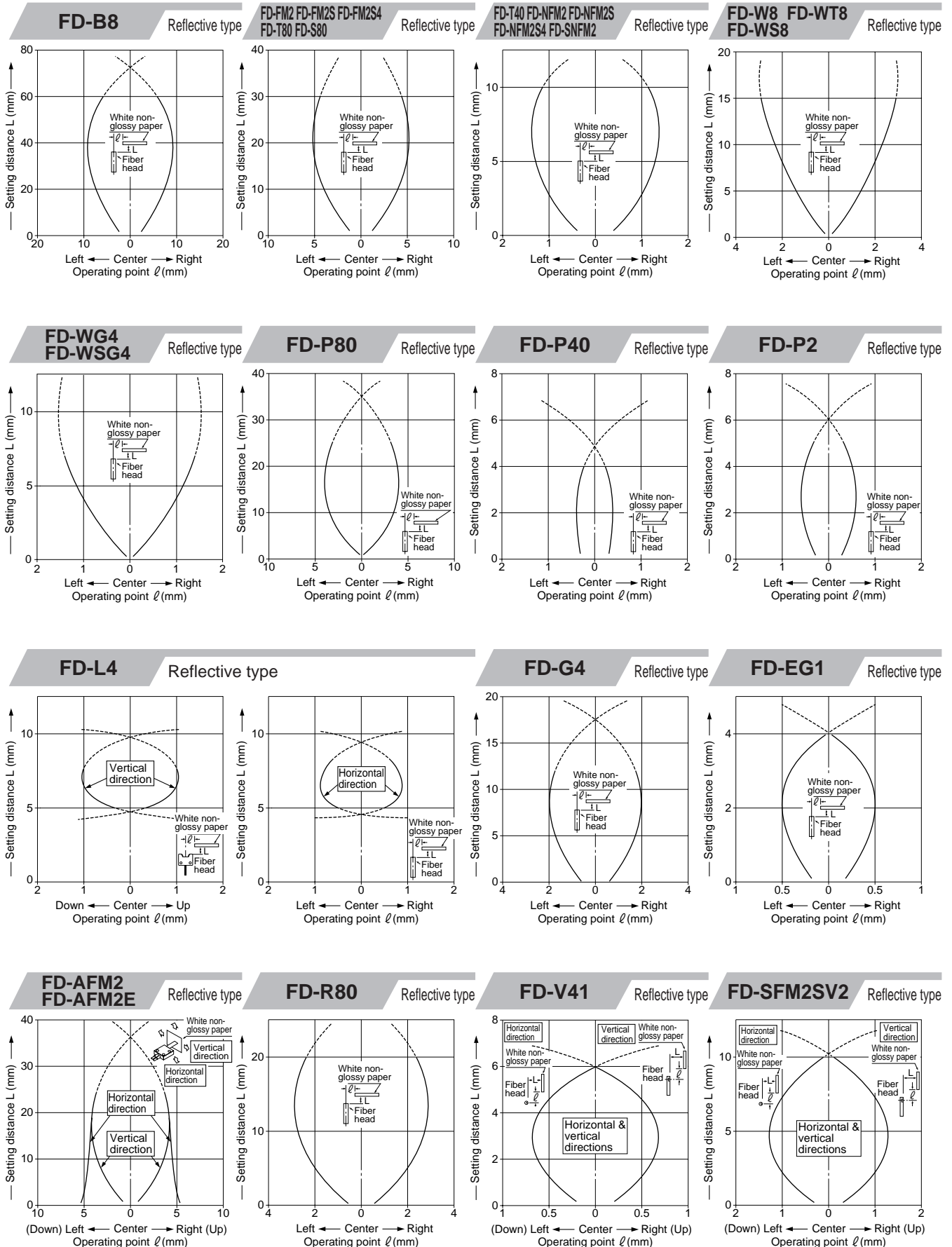

# FX-13

## SENSING CHARACTERISTICS (TYPICAL)

### Sensing fields

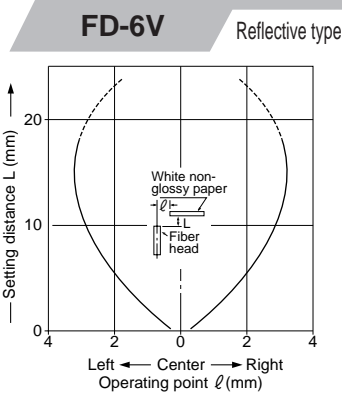
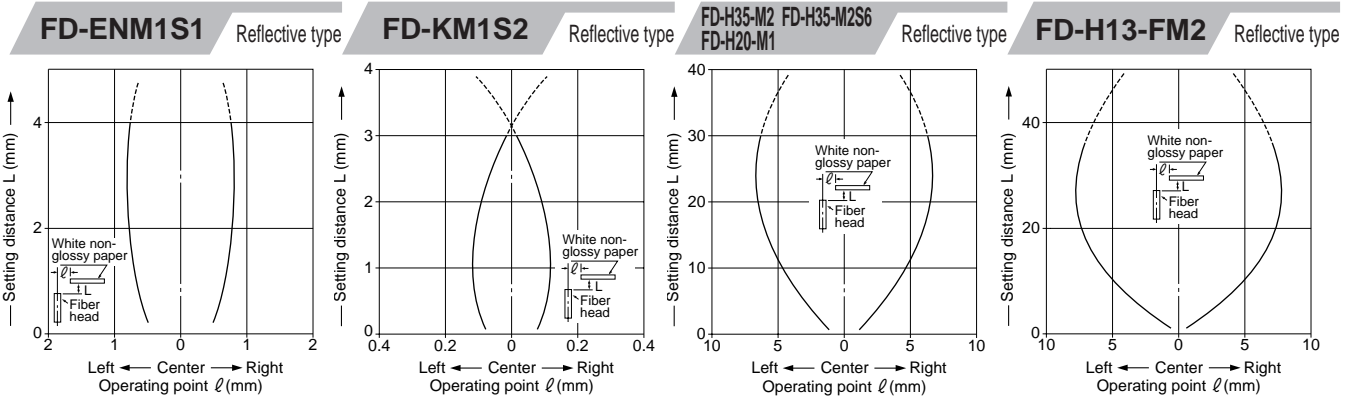

### Sensing fields with FX-MR1 (pinpoint spot lens) applied

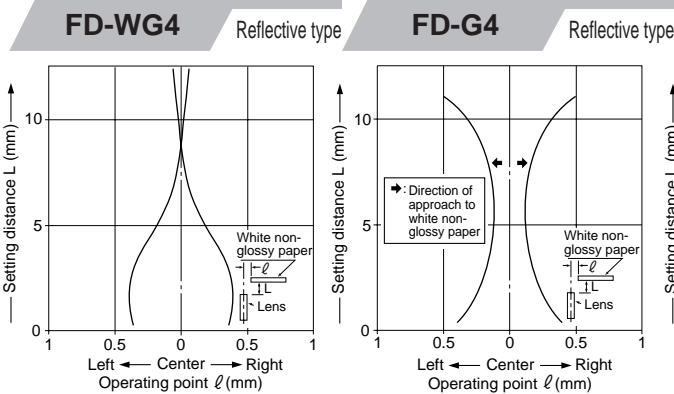

### Sensing fields with FX-MR2 (zoom lens) applied

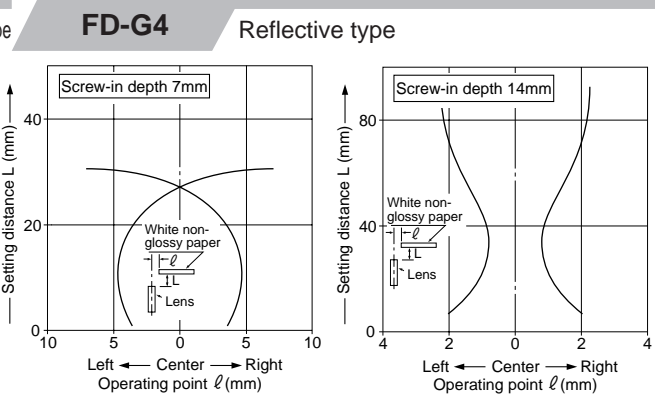

### Sensing fields with FX-MR3 (finest spot lens) applied

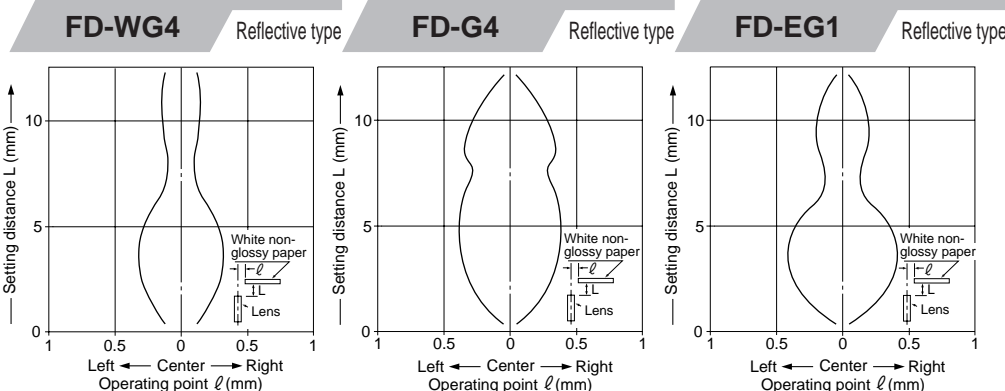

## SENSING CHARACTERISTICS (TYPICAL)

Sensing fields with FX-MR5 (side-view type zoom lens) applied

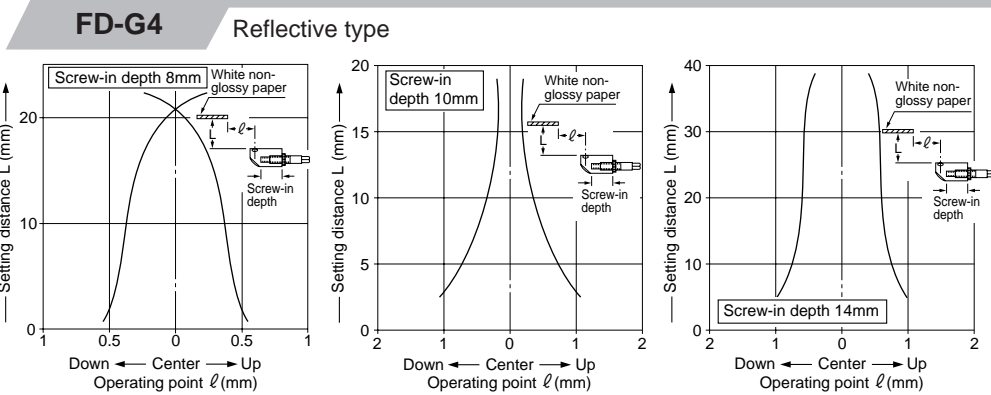

Correlation between sensing object diameter and sensing wire field

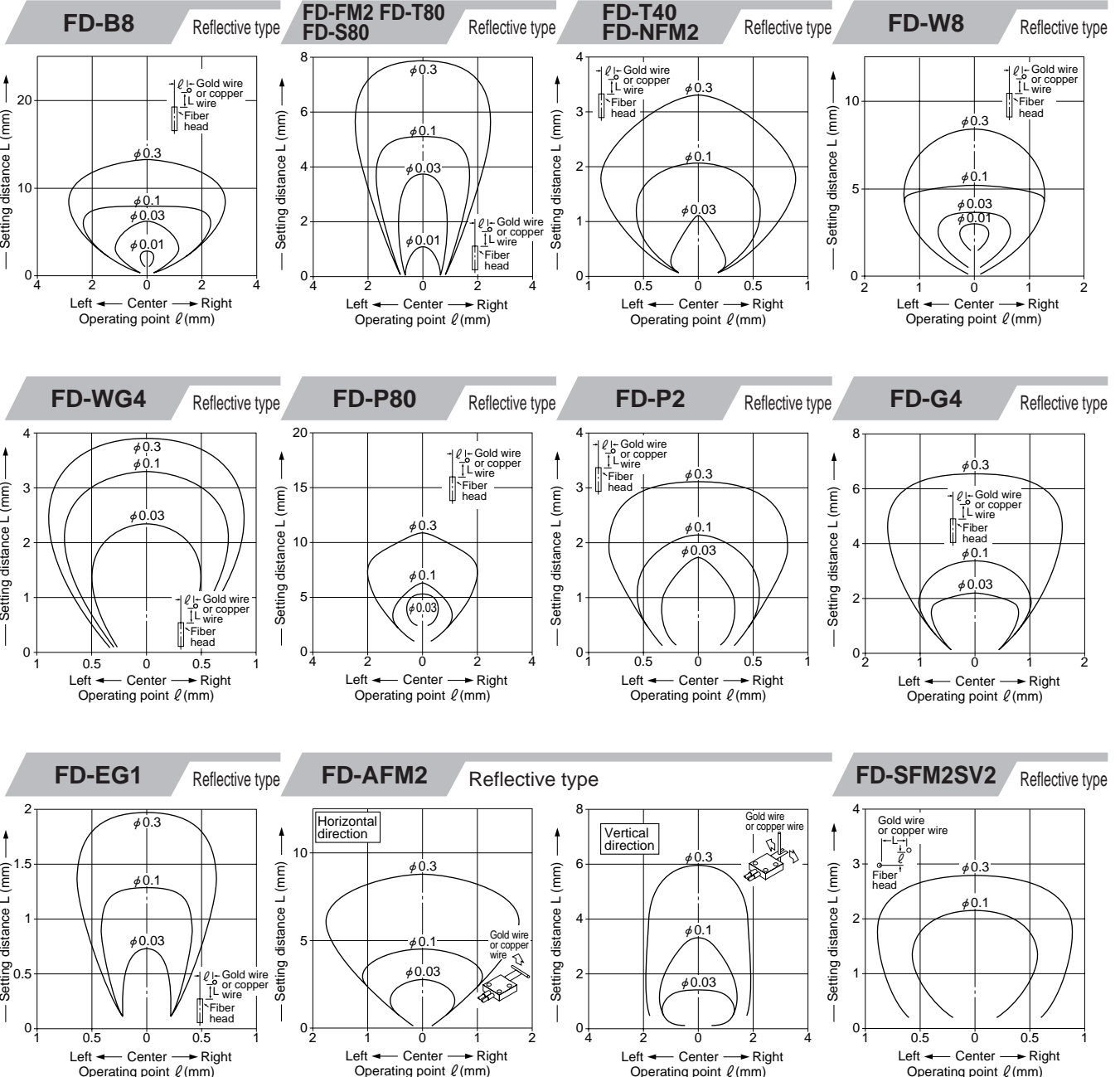

## SENSING CHARACTERISTICS (TYPICAL)

## Correlation between sensing object diameter and sensing field

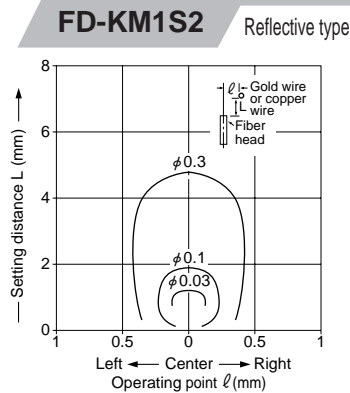

## PRECAUTIONS FOR PROPER USE

Refer to P.820~ for general precautions and P.99~ for fiber precautions.

## Amplifier



This product is not a safety sensor. Its use is not intended or designed to protect life and prevent body injury or property damage from dangerous parts of machinery. It is a normal object detection sensor.

## Mounting

## How to mount the amplifier

- Fit the rear part of the amplifier on the attached amplifier mounting bracket (**MS-DIN-2**) or a 35mm width DIN rail.
- Press down the front part of the amplifier on the amplifier mounting bracket (**MS-DIN-2**) or the DIN rail to fit it.

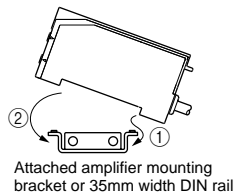

## How to remove the amplifier

- Push the amplifier forward.
- Lift up the front part of the amplifier to remove it.

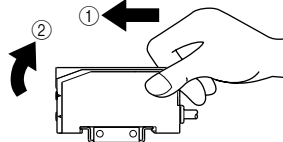

Note: Please take care that if the front part is lifted without pushing the amplifier forwards the hooks on the rear portion of the mounting section are likely to break.

## How to connect the fiber cables

- Snap the fiber lock lever down.
- Insert fiber cables slowly into the inlets until they stop. (Note 1)
- Lock the fiber lock lever in the original position, till you feel a click.

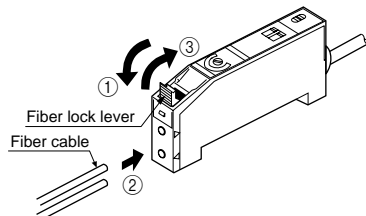

Notes: 1) In case the fiber cables are not inserted to a position where they stop, the sensing range reduces.

2) With the coaxial reflective type fiber, such as, **FD-G4** or **FD-FM2**, insert the center fiber cable (single-core) into the beam-emitting inlet and the outer fiber cable (multi-core) into the beam-receiving inlet. If they are inserted in reverse, the sensing accuracy will deteriorate.

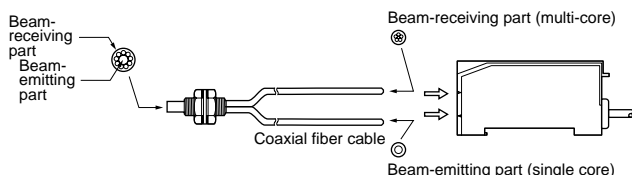

## OFF-delay timer function

- FX-13** incorporates an approx. 40ms fixed OFF-delay timer. Timer operation is effective when the timer operation mode switch is set to the 'OFD' side.

Since the output is extended by a fixed period, it is useful when the connected device has a slow response time or when small objects are being sensed and the output signal width is small.

## &lt;Time chart&gt;

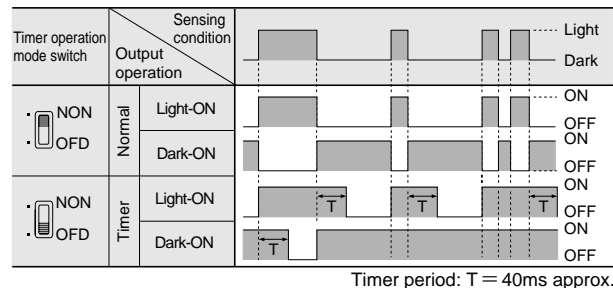

## Wiring

- The self-diagnosis output is not incorporated with a short-circuit protection circuit. Do not connect it directly to a power supply or a capacitive load.

## Others

- Do not use during the initial transient time (50ms) after the power supply is switched on.

## PRECAUTIONS FOR PROPER USE

Refer to P.820~ for general precautions and P.99~ for fiber precautions.

### Amplifier

#### Self-diagnosis function

- This is a function which diagnoses a decrease in the incident light intensity due to dirt or dust, or optical misalignment, and gives an output.

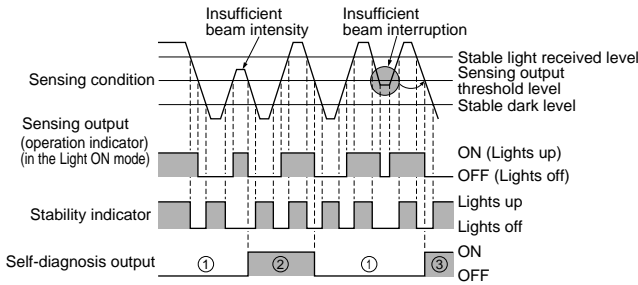

- The self-diagnosis output transistor stays in the 'OFF' state during stable sensing.
- When the sensing output changes, if the incident light intensity does not reach the stable light received level or the stable dark level, the self-diagnosis output becomes ON. Further, the self-diagnosis output is generated at the time when the sensing output changes from Light to Dark state. (The operation of the sensing output is not affected.)
- In case of insufficient beam interruption, there will be a time lag before the self-diagnosis output turns ON.

#### Part description

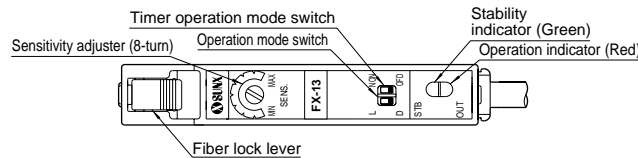

## DIMENSIONS (Unit: mm)

### FX-13 FX-13P Amplifier

#### Assembly dimensions with attached amplifier mounting bracket

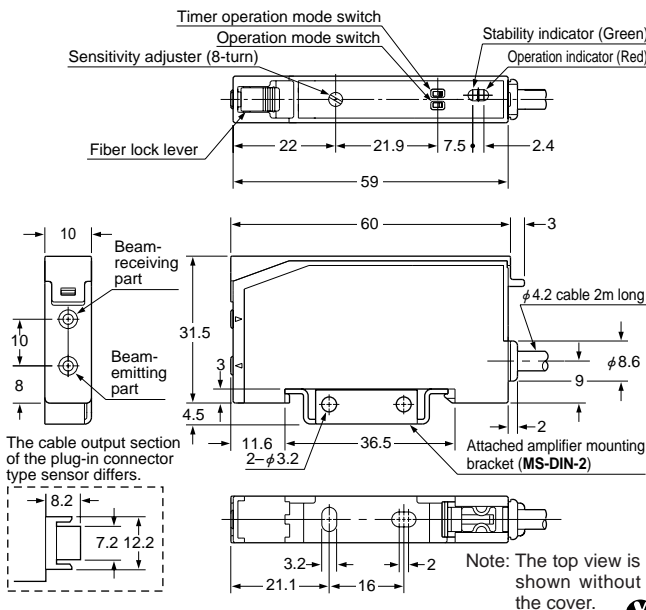

#### Sensitivity adjustment

- Adjust the sensitivity while observing the operation indicator.

Sensing condition	MODE	Operation indicator
		☼: Light up ●: Light off
Light	L-ON (Light-ON)	☼
	D-ON (Dark-ON)	●
Dark	L-ON (Light-ON)	●
	D-ON (Dark-ON)	☼

- The sensitivity adjuster is an 8-turn potentiometer. The maximum sensitivity is obtained by turning fully clockwise.
- The indicator shows the present sensitivity level.

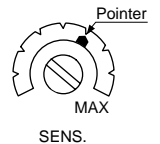

Step	Sensing method		Operation	Sensitivity adjuster
	Reflective	Thru-beam		
①			Set the operation mode switch to Light-ON mode. (Initial setting)	Turn the sensitivity adjuster fully counterclockwise. (Minimum sensitivity)
②	Beam received	Beam received		In the beam received condition, slowly turn the adjuster clockwise and find the point (A) where the sensor is switched ON.
③	Beam not received	Beam not received		In the beam not received condition, turn the adjuster further clockwise until the sensor goes into the ON state again. Once it is switched on, turn the adjuster counterclockwise a little and find the point (B) where it is switched OFF. (If the sensor does not go into the ON state, MAX is the point (B).)
④				Set the adjuster at the center of points (A) and (B). This is regarded as the optimum sensitivity point.
⑤				Select the mode either Light-ON or Dark-ON according to your application. (L-ON: ON when the beam is received, D-ON: ON when the beam is not received)

- Notes: 1) In order to protect the mechanism, the sensitivity adjuster idles when over turned.  
2) Do not move or bend the fiber cable after the sensitivity adjustment. Detection may become unstable.

Refer to P.106~ for dimensions other than those given below.

### MS-DIN-2 Amplifier mounting bracket (Accessory for amplifier)

