



EWS / EWS2 phase sequence and loss of phase EWS Part number 84892299



- Space savings, accurate measurement and optimized functions all improve the efficiency of your electrical installation.
- Control : You simply install your EWS phase control relay and without any adjustment you can monitor the loss or inversion of one of the phases.
- Safety : The EWS range enables you to choose the level of safety for your installation by using versions with 1, 2 or 3 output changeovers.
- Self-powered : Simple to install, EWS control relays use the controlled mains supply for their own power supply voltage.

Part numbers

Type	Output relay
84 892 299 EWS	1 changeover

Specifications

Operating range	200 →500 VAC
Operating range	3 AC 230...440 V
Frequency	50 / 60 Hz +/- 1 Hz
Maximum consumption	25 VA
Output relay	1 or 2 changeovers
Type of contacts	No cadmium
Nominal rating	8 A
Maximum breaking voltage	250 V AC
Max. voltage	440 V AC
Nominal breaking capacity	2000 VA
Min. breaking current	10 mA / 5 V
Electrical life (number of operations)	AC 12 : 10 ⁵ at 8A/250 VAC
Maximum rate (at full load)	360 operations / hour
Mechanical life (operations)	2 x 10 ⁷
Pick-up delay T1	200 ms
Turn-off delay T2	300 ms in the event of phase failure
Connection capacity - without ferrule	2 x 2,5 mm ² 1 x 4 mm ²
Connection capacity - with ferrule	2 x 1,5 mm ²
Max. tightening torque	1 Nm (screw M3 / IEC/EN 60947-1)
Operating temperature range (°C)	-20 →+50
Storage temperature (°C)	-30 →+70
Housing material	Self-extinguishing
Protection (IEC/EN 60529) - Casing	IP40
Protection (IEC/EN 60529) - Term. block	IP20
Dielectric strength (IEC/EN 60255-5)	2,5 KV / 1 mn / 1 mA / 50 Hz
Insulation coordination (IEC/EN 60664-1)	Overvoltage category III, degree of pollution 3
Weight (g)	110

Principles

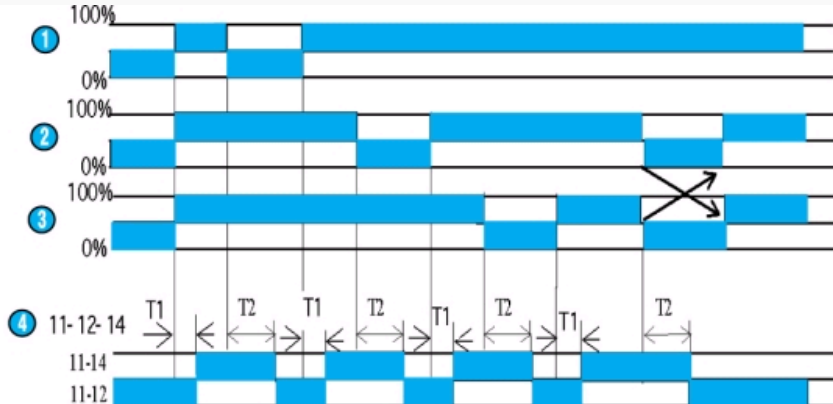

Operating principle

EWS/EWS2 relays monitor the correct sequencing of phases L1, L2 and L3 as well as the loss of one of these phases.

When the phase sequence is correct, the output relay is energised, indicated by a yellow LED.

The relay de-energises (LED off) if one of the following faults occurs : Incorrect sequence of phases at terminals L1, L2 and L3

Total loss of one phase or all three phases (loss of phase detection threshold < 50 VAC)

N°	Legend
①	Phase L1
②	Phase L2
③	Phase L3
④	Relay

Dimensions (mm)

EWS / EWS2

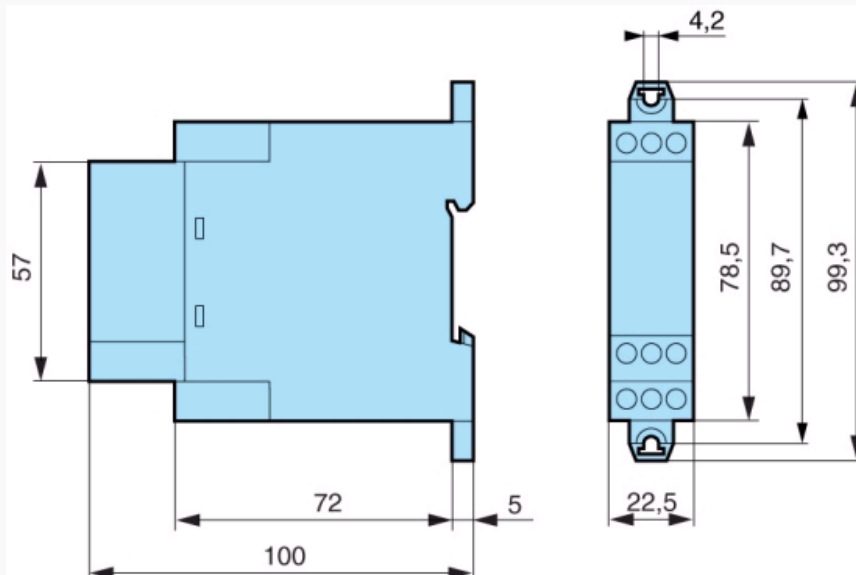
**Connections**

EWS

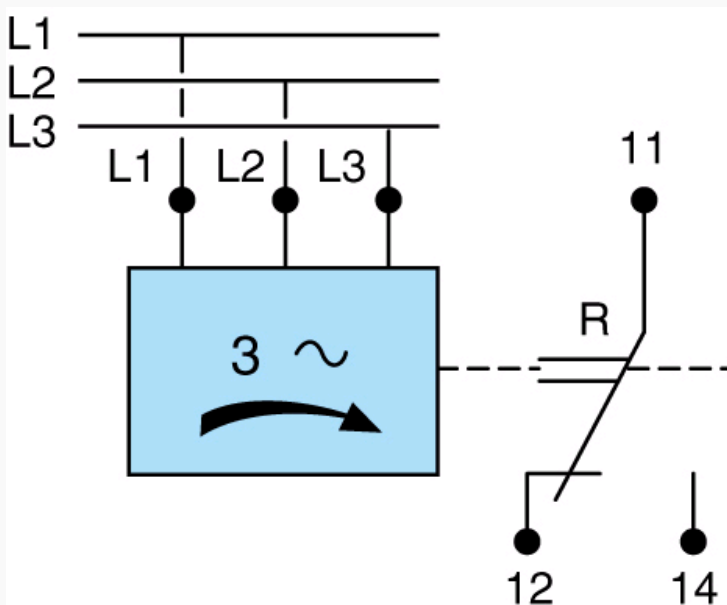
**Connections**

EWS

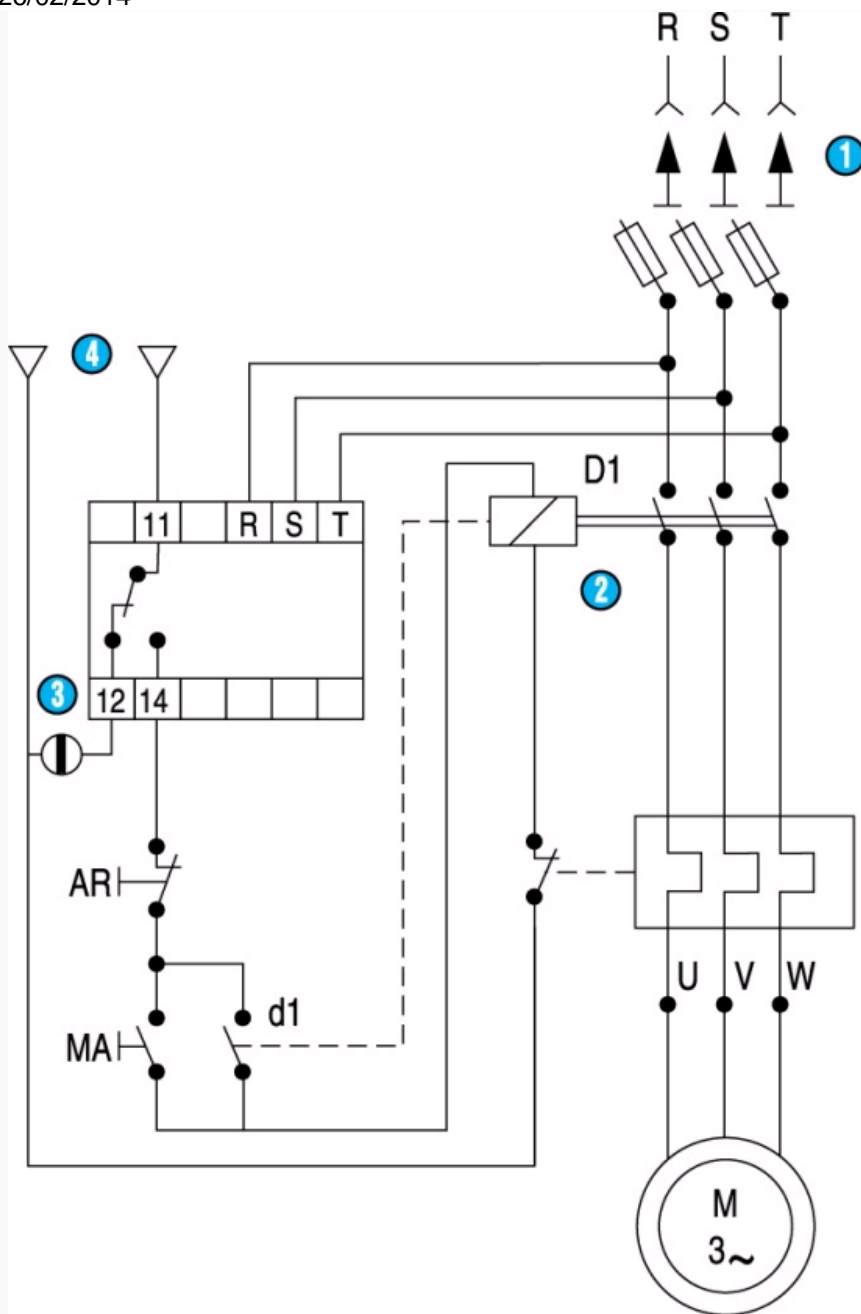

Surveillance moteur triphasé Réenclenchement manuel après disparition du défaut. defecto

N°	Legend
1	Isolating switch
2	Contacteur
3	Alarm
4	Auxiliary power supply for contactor coil and signalling