

ENERGIZER 379

SILVER OXIDE

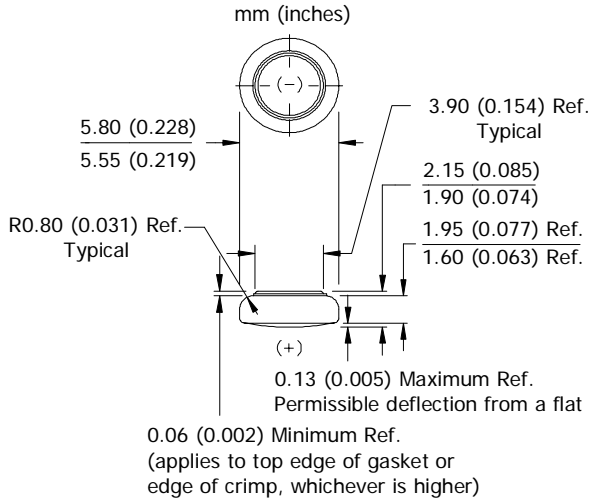

Industry Standard Dimensions



Specifications

Chemical System: Silver Oxide (Zn/Ag₂O)
Designation: ANSI/NEDA-1191SO
Nominal Voltage: 1.55 Volts
Typical Capacity: 14.5 mAh* (to 1.3 volts)
Capacity Test: 68K ohm continuous drain at 21°C
Typical Weight: 0.25 grams (0.009 oz.)
Typical Volume: 0.06 cubic centimeters (0.003 cubic inch)
Impedance (40 Hz): 75 to 85 ohms

* Varies according to the applied load, temperature, and cutoff voltage.

Cross Section

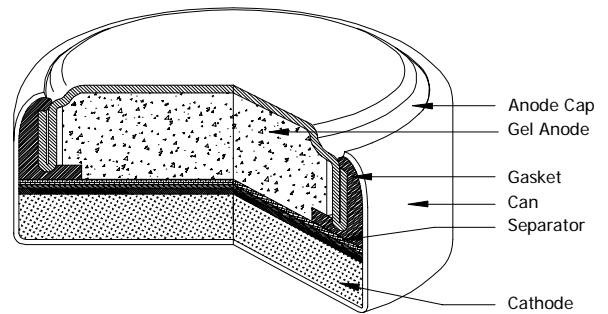

DESIGNED FOR USE ON CONTINUOUS LOW DRAIN

Typical Discharge Characteristics

Typical Performance at 21°C (70°F)

Schedule: Continuous
Typical Drain @1.55V:
 0.023 milliamperes
Load: 68K ohm

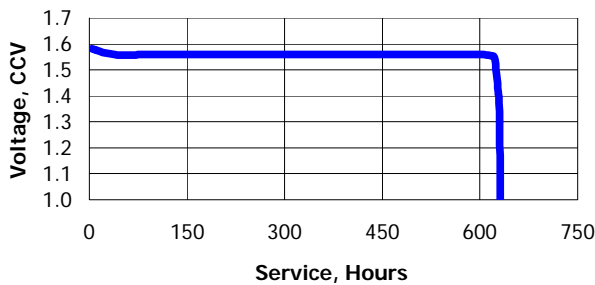

<u>Schedule</u>	<u>Typical Drains</u> at 1.55V (milliamperes)	<u>Load</u> (ohm)	<u>Cutoff</u> 1.3V (hours)
Continuous	0.023	68K	630

Temperature Characteristics

Typical Performance at Low Discharge Rates

Service Effects

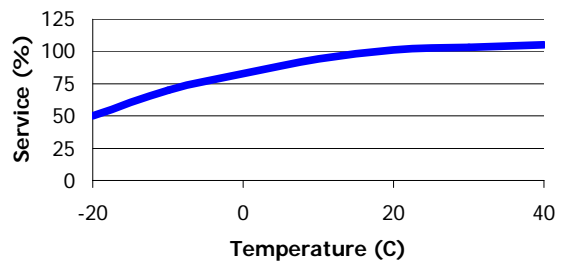

Storage Effects

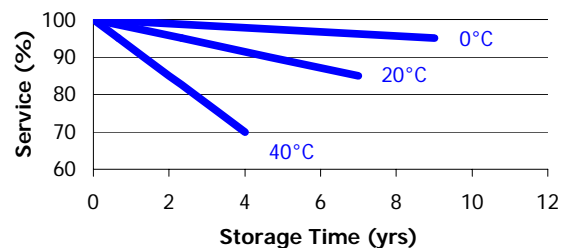

Important Notice

This datasheet contains typical information specific to products manufactured at the time of its publication.

©Energizer Holdings, Inc. - Contents herein do not constitute a warranty.