

PRODUCT NUMBER	NO. OF POS	DIM K	DIM J	DIM C	DIM W DIM Z
78211-003LF	3	7.47	5.08	1.35	0.05
78211-004LF	4	10.01	7.62	1.35	0.05
78211-005LF	5	12.55	10.16	1.35	0.05
78211-006LF	6	15.09	12.70	1.35	0.10
78211-007LF	7	17.63	15.24	1.35	0.10
78211-008LF	8	20.17	17.78	1.35	0.10
78211-009LF	9	22.71	20.32	1.35	0.10
78211-010LF	10	25.25	22.86	1.35	0.10
78211-011LF	11	27.79	25.40	1.35	0.15
78211-012LF	12	30.33	27.94	1.35	0.15
78211-013LF	13	32.87	30.48	1.35	0.15
78211-014LF	14	35.41	33.02	1.35	0.15
78211-015LF	15	37.95	35.56	1.35	0.15
78211-103LF	3	7.47	5.08	2.54	0.05
78211-105LF	5	12.55	10.16	2.54	0.05
78211-106LF	6	15.09	12.70	2.54	0.10

EXTENDED RANGE

- TOOLING FEASIBILITY CONFIRMED
- SAMPLES ON DEMAND
- AVAILABILITY ON DEMAND

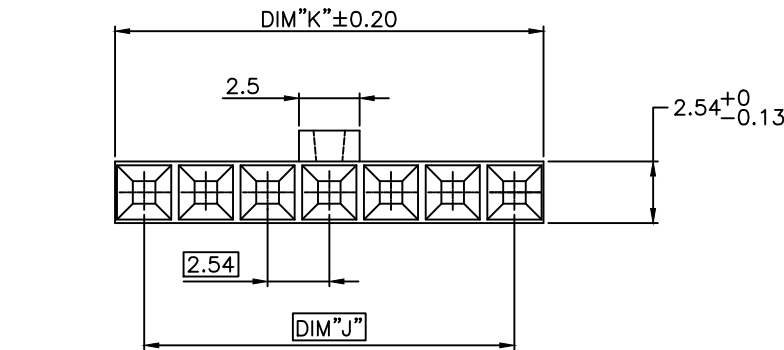
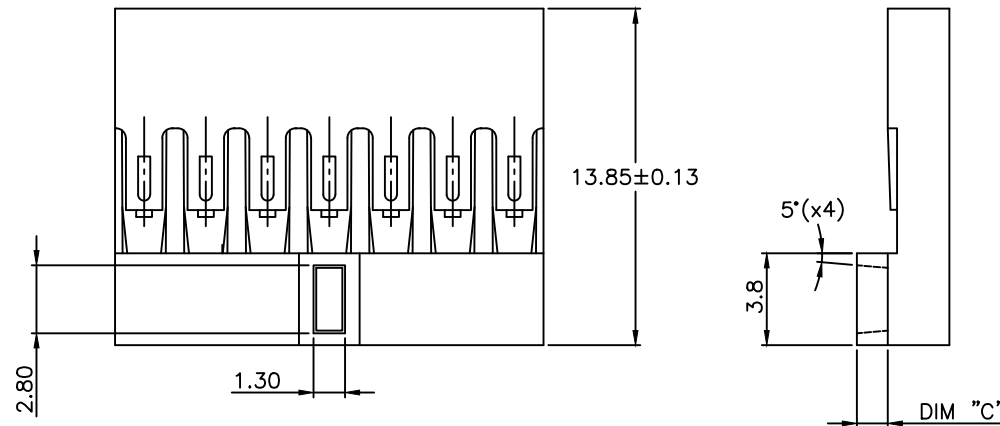

NOTES:

- 1 - MOLDING MATERIAL: MODIFIED POLYPHELYNENE
COLOR BLACK, UL 94 V0
- 2 - LATCH MUST WITHSTAND 18N MIN PULL OUT FORCE
- 3 - STANDARD PACKAGING IN POLYBAGS
- 4 - TERMINALS MUST BE CRIMPED PROPERLY FOR SATISFACTORY LATCHING :
- FOR CRIMPING INSTRUCTIONS, SEE TA-75 AND TA-295
- FOR TERMINAL APPLICATION SEE TA-531.
PRODUCT SPECIFICATION: BUS-12-067.
- 5 - THIS HOUSING IS INTENDED FOR USE WITH MINI PV TERMINAL WITH 22-36 GAUGE WIRE
- 6 - RoHS COMPLIANT PRODUCT SPECIFICATIONS :
- MEETS PACKAGING SPECS AS PER GS-14-920
- PRODUCT MEETS EUROPEAN UNION DIRECTIVES AND OTHER COUNTRY REGULATIONS AS DESCRIBED IN GS-22-008.
- THE PRODUCT IS NOT INTENDED TO BE EXPOSED TO A MANUFACTURING SOLDER PROCESS.
- 7 - THIS PART SERIES IS NOT INITIALLY INTENDED FOR AUTOMOTIVE APPLICATIONS. ADDITIONAL FEES ARE CHARGEABLE FOR ANY ADDITIONAL QUALIFICATION AND TEST REPORTS PERFORMED OUTSIDE THE SCOPE OF THE STANDARD PRODUCT SPECIFICATIONS.
- 8 - UNLESS OTHERWISE APPROVED BY AMPHENOL, ALL PARTS AND COMPONENTS ARE DESIGNED & BUILT ACCORDING TO AMPHENOL'S SPECIFICATIONS WHICH ARE SUBJECT TO CHANGE WITHOUT NOTICE.

mat'l. code		surface		tolerance		projection		product family	
SEE NOTES		ISO 1302 ✓		ISO 406 ISO 1101				BERGCON	
ltr	ecn no	dr	date	tolerances unless otherwise specified		mm		title	
K	v07-0533	HTB	07.08.21	linear				MINI LATCH	
L	B-14321	LMU	13.03.21					HOUSING SR POLARIZED	
M	F-30075	DDE	18.05.03			scale 5:1		dwg no	
N	F-54573	DDE	25.02.10	dr	L.MULIN	13.03.21	sheet 1 of 1		size
P	F-54605	DDE	25.02.12	enfr	L.MULIN	13.03.21	Amphenol		A3
R	F-54971	DDE	25.03.14	chr	J.COMPAGNON	13.03.21	FCI		
				appd	L.MULIN	13.03.21	type		Drawing
sheet	revision								
index	sheet								