

Part Number	Description
FS24R10-06	10A, 280 Vac
FS24D10-06	10A, 280 Vac
FS24D10	10A, 280 Vac
FS24D20-06	20A, 280 Vac

Part Number Explanation

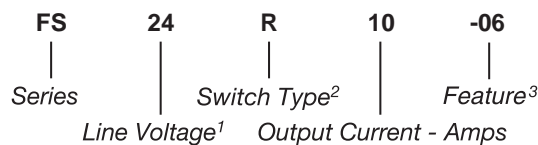

NOTES

- 1) Line Voltage (nominal): 24 = 240 Vac
- 2) Switch Type: R = Random turn-on; D = Zero-cross turn-on;
- 3) Feature: -06 = Faston terminals

MECHANICAL SPECIFICATION

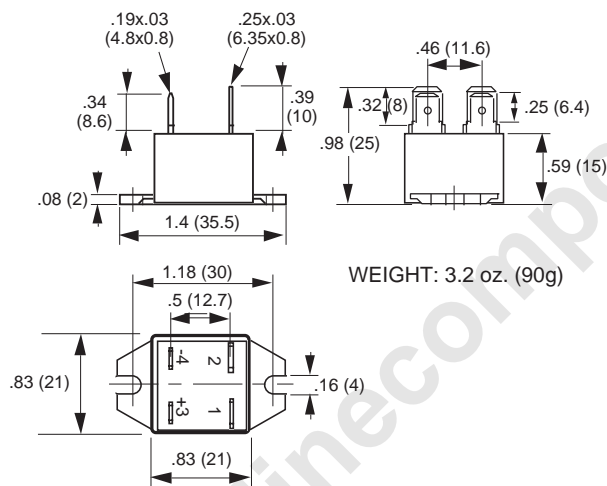

Figure 1a — FS relays except FS24D10

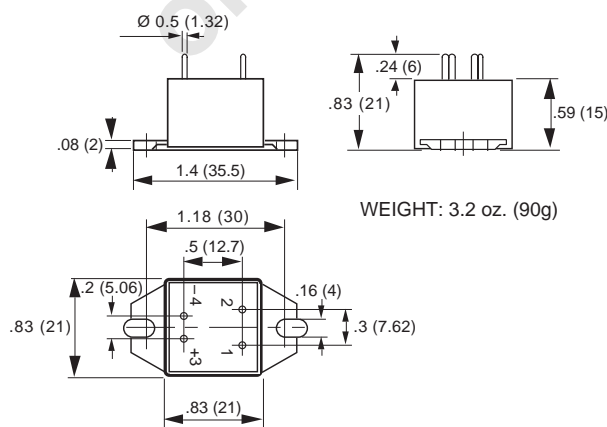

Figure 1b — FS24D10



FEATURES/BENEFITS

- Miniature size package
- Designed for medium-power applications
- Faston or PCB terminals available
- Tight zero-cross window for low EMI
- Excellent thermal performance
- High immunity to surges

DESCRIPTION

The Series FS relays are designed for medium-power loads. The design incorporates a triac output. The Series FS relays utilize optical isolation to protect the control from load transients. The FS compact package is available with faston or PCB terminals. Its compact size makes it ideal for designs where space is limited. The Series FS relays have excellent thermal performance.

APPLICATIONS

- Heating control
- Motor control
- Uninterruptible power supplies
- Light dimmers
- Industrial and process control
- On/Off controls of medium-power AC equipment
- Electromechanical line relay replacement

APPROVALS

All models are UL recognized.
UL File Number E128555.

EQUIVALENT CIRCUIT

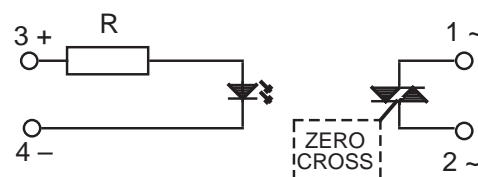

Figure 2 — FS relays



A Unit of Teledyne Electronics and Communications

Series FS

INPUT (CONTROL) SPECIFICATION

	Min	Max	Units
Control Range			
FS24R	3	30	Vdc
FS24D	4	30	Vdc
Input Current Range			
FS24R	2	30	mAdc
FS24D	3	30	mAdc
Must Turn-Off Voltage			
All relays		1	Vdc
Input Resistance (Typical)			
All relays		1000	Ohms
Reverse Voltage Protection			
All relays		30	V

OUTPUT (LOAD) SPECIFICATION

Input Type	Min	Max	Units
Operating Range			
All relays	12	280	Vrms
Peak Voltage			
All relays		600	Vpeak
Load Current Range (Resistive)			
10A output current	.005	10	Arms
20A output current	.005	20	Arms
Inductive Load Current			
10A output current		2.5	Arms
20A output current		4	Arms
Maximum Surge Current Rating (Non-Repetitive)			
10A output current		120	A
20A output current		200	A
On-State Voltage Drop			
All relays output current		1.3	V

CONTROL CHARACTERISTIC

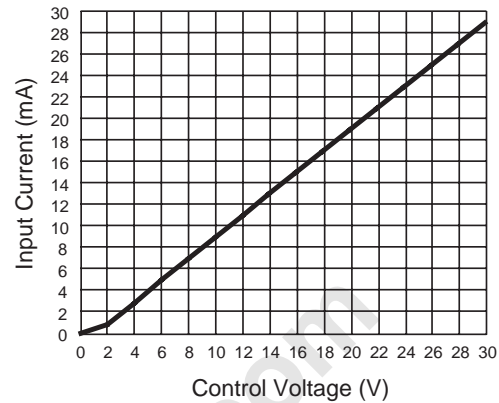

Figure 3 — FS relays

OUTPUT (LOAD) SPECIFICATION (Continued)

	Min	Max	Units
Zero Cross Window (Typical)			
FS24 R		NA	
FS24 D		12	Vac
Off-State Leakage Current (60Hz)			
All relays		3	mA
Turn-On Time (60 Hz)			
FS24R		0.1	ms
FS24D		8.3	ms
Turn-Off Time (60 Hz)			
All relays		8.3	ms
Off-State dv/dt			
All relays		500	V/μs
Maximum di/dt (Non-Repetitive)			
All relays		50	A/μs
Operating Frequency Range			
All relays	0.1	440	Hz
I²t for Match Fusing (<8.3ms)			
10A output current	.005	72	A ² S
20A output current	.005	200	A ² S

ENVIRONMENTAL SPECIFICATION

	Min	Max	Units
Operating Temperature	-40	100	°C
Storage Temperature	-40	100	°C
Input-Output Isolation	4000		Vrms
Output-Case Isolation	2500		Vrms

NOTES:

1. External snubber is recommended when switching inductive loads.
2. Electrical specifications at 25°C unless otherwise specified.
3. For 800Hz applications, contact factory.
4. For additional/custom options, contact factory.

SURGE CURRENT

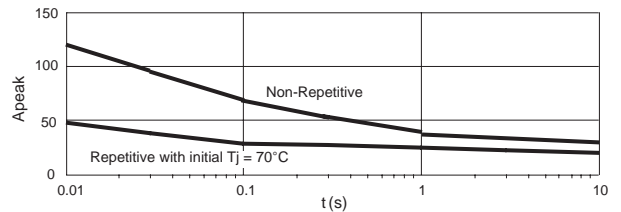

Figure 4a — All 10A FS relays output current

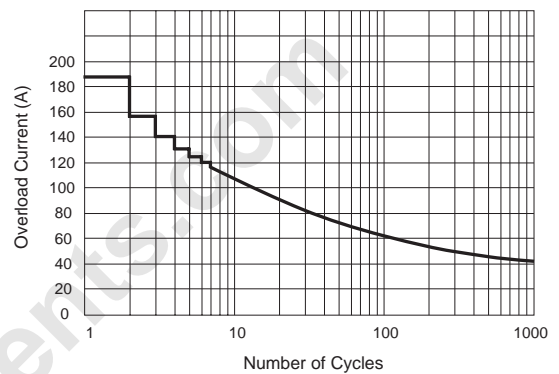

Figure 4b — FS24D20-06 output current

THERMAL CHARACTERISTICS

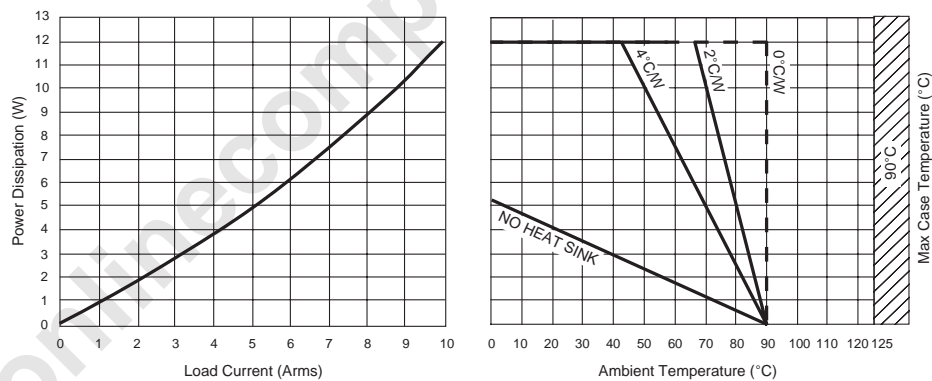

Figure 5a — All 10A FS relays output current

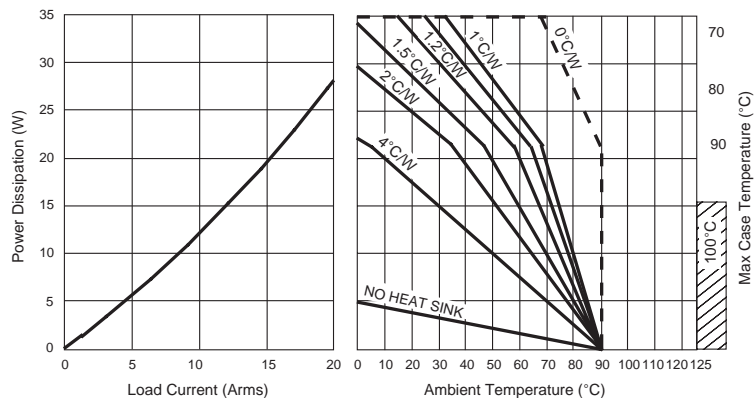

Figure 5b — FS24D20-06 output current