

TOP VIEW

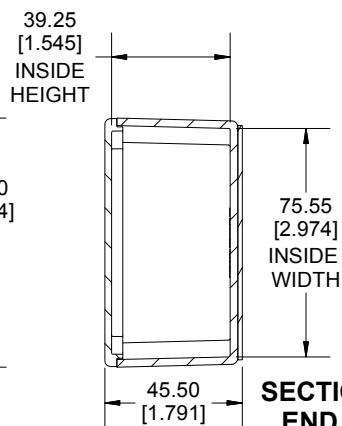

**SECTION A-A
END VIEW**

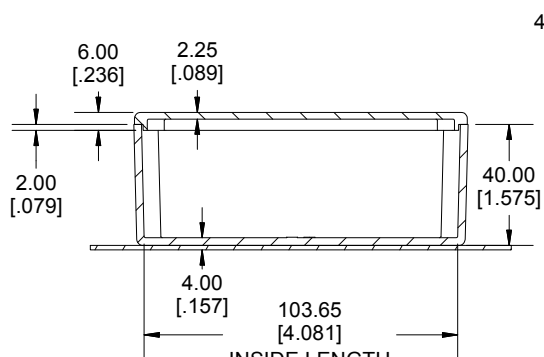

**SECTION B-B
SIDE VIEW**

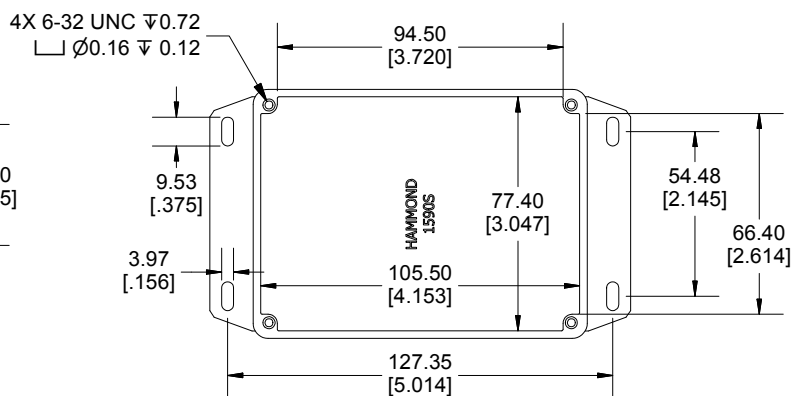

INSIDE BOX

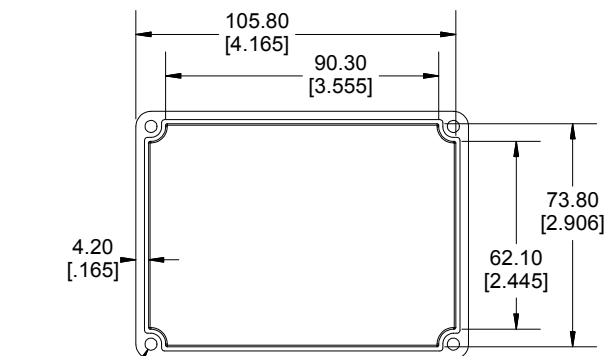

INSIDE LID

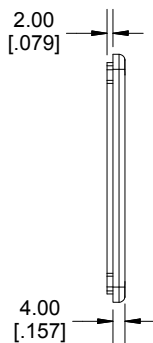

Enclosures can be Factory Modified (Milling, Drilling, Printing etc.)
 Contact Factory mjm@hammondmfg.com for quotes
 Solid models of this enclosure available in STEP or IGES.
 (Part number and text placement/orientation on our products are subject to change,
 we do not recommend using them as a locating reference for modification purposes)

NOTE

Purchased assembly includes box, lid and 4 cover screws.
 Box and lid are made from Diecast Aluminum Alloy.
 Silicone Gasket supplied with liquid resistant enclosure.
 Bottom Flange is Welded.

Recommended Torque: 50-55 cN.m [71-78 ozf.in]

Recommended Torque with Gasket : 25-30 cN.m [36-43 ozf.in]

PART NUMBERS

1590SF Enclosure

Natural Finish Enclosure	1590SF
Black Textured Enclosure	1590SFBK
1590SF Liquid Resistant Enclosure (Silicone Gasket)	
Natural Finish Enclosure	1590WSF
Black Textured Enclosure	1590WSFBK

ACCESSORIES

Liquid Resistant Cover Screws

Stainless Steel Cover Screws (Pkg 100) [6-32 x 1/2" With O-Ring]	1590WMS100
Black Stainless Steel Cover Screws (Pkg 100) [6-32 x 1/2" With O-Ring]	1590WMS100BK
Standard Cover Screws	
Plated Cover Screws (Pkg 100) [6-32 x 1/2"]	1590MS100
Black Cover Screws (Pkg 100) [6-32 x 1/2"]	1590MS100BK

Dimensions:
mm
[inches]

**HAMMOND
MANUFACTURING®**

1590SF

www.hammondmfg.com