

Studded Power Feed Thru Terminal Blocks

ST723B38 Series (back mount)

Specifications:

Electrical:

- 600 Volts AC/DC (UL 1059 Class B and C)
- 380 Amps
- Wire Range 500 kcmil - 2/0 AWG
- Accommodates Two Hole Compression Lugs on 1" Centers - wires larger than 250 kcmil require narrow lug

Mechanical:

- Base, Thermoplastic, 125°C (UL RTI)
- Flammability, UL 94 V-O
- Studs, 3/8" - 16, Brass, Nickel Plated
- Mounting hardware included (4) #10-32 Screws
- Application Torque: 192 lbf-in
- UL Recognized File No. XCFR2.E62806
- cURus Certified File No. XCFR8.E62806
- RoHS Compliant



ST723B3802

Hardware Options:

- (blank) – No hardware
- UH – All nuts shipped bulk
- AH – All nuts assembled
- DL – Assembled barrier side, remainder shipped bulk

ST723B3801 - One Pole

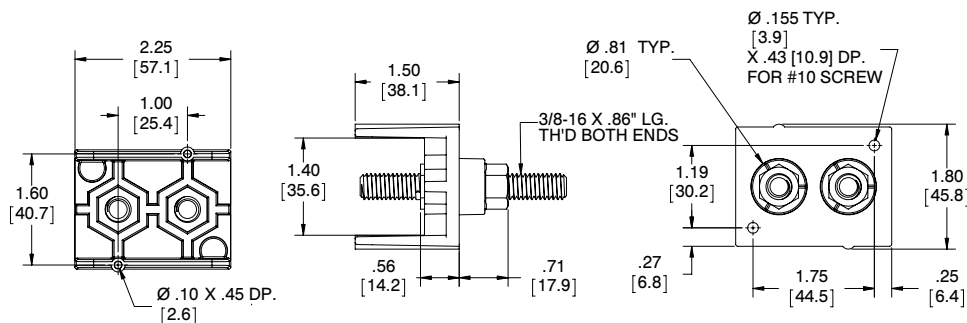

ST723B3802 - Two Poles

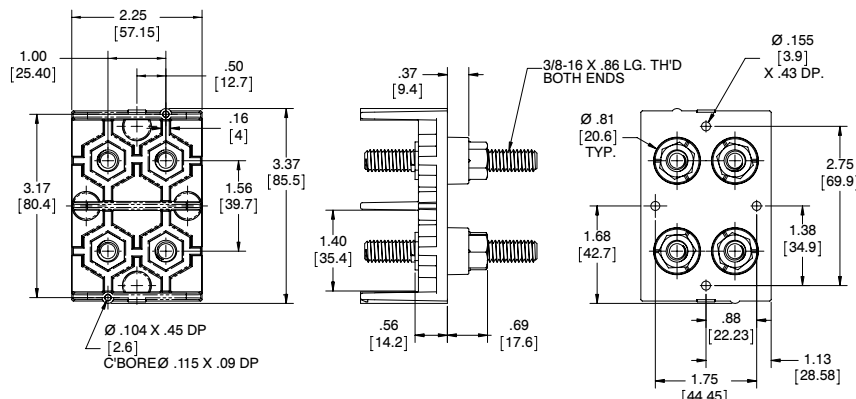

For electronic drawings or 2D/3D CAD data, submit request at www.marathonsp.com/drawings.html