

FocusLCDs.com

RELIABILITY AND SUPPORT FOR LESS

TFT | CHARACTER | VATN | FSC | SEGMENT
CUSTOM | REPLACEMENT

LCD's Made Simple

Phone-480-503-4295 | Email-NOPP@FocusLCD.com

TFT Display Module

Part Number

E70RG38048LW2M450-N

Overview

800x480(165x100), 16/18/24 bit RGB
Interface, WHITE LED backlight, Top view,
Wide temp, Transmissive, No Touch
Panel, 450 NITS, Controller: EK9713/
EK7330, RoHS Compliant

Contents

General Description	4
1. Block Diagram	5
2. Outline dimension	6
3. Input Terminal Pin Assignment	7
4. LCD Optical Characteristics	9
5. Electrical Characteristics	12
6. AC Characteristic	14
7. LCD Module Out-Going Quality Level	16
8. Reliability Test Result	24
9. Cautions and Handling Precautions	25
10. Packing	26

General Description

* Description

This is a color active matrix TFT (Thin Film Transistor) LCD (liquid crystal display) that uses amorphous silicon TFT as a switching device. This model is composed of a Transmissive type TFT-LCD Panel, driver circuit, back-light unit. The resolution of a 5.0TFT-LCD contains 800x480 pixels, and can display up to 65K/262K/16.7M colors.

* Features

-Low Input Voltage: 3.3V(TYP)

-Display Colors of TFT LCD: 65K/262K/16.7M colors

- Interface: 16/18/24 bit RGB

General Information Items	Specification	Unit	Note
	Main Panel		
Display area(AA)	154.08 (H) *85.92 (V) (7.0inch)	mm	-
Driver element	TFT active matrix	-	-
Display colors	65K/262K/16.7M	colors	-
Number of pixels	800(RGB)*480	dots	-
Pixel arrangement	RGB vertical stripe	-	-
Pixel pitch	0.0642(H)*0.01790(V)	mm	-
Viewing angle	12:00	o'clock	-
Controller IC	EK9713/EK7330	-	-
Display mode	Transmissive/ Normally White	-	-
Operating temperature	-20~+70	°C	-
Storage temperature	-30~+80	°C	-

* Mechanical Information

Item		Min.	Typ.	Max.	Unit	Note
Module size	Horizontal(H)		120.70		mm	-
	Vertical(V)		75.80		mm	-
	Depth(D)		5.8		mm	-
Weight			TBD		g	-

1. Block Diagram

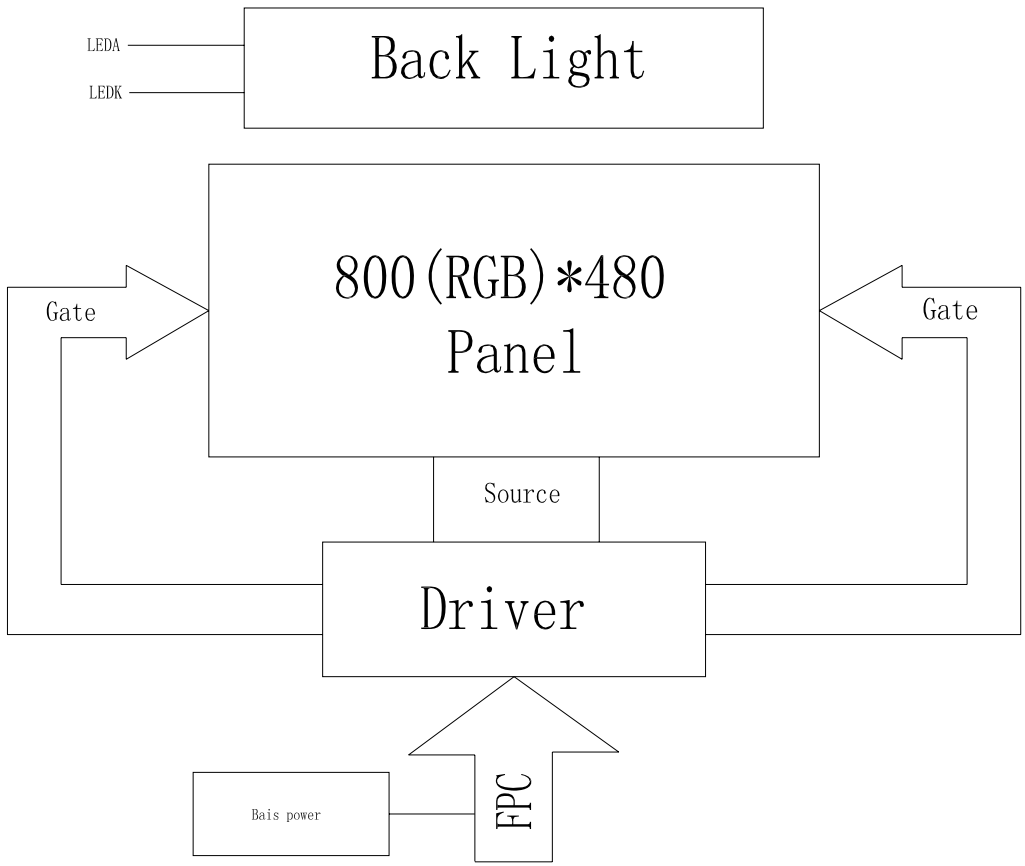

2. Outline dimension

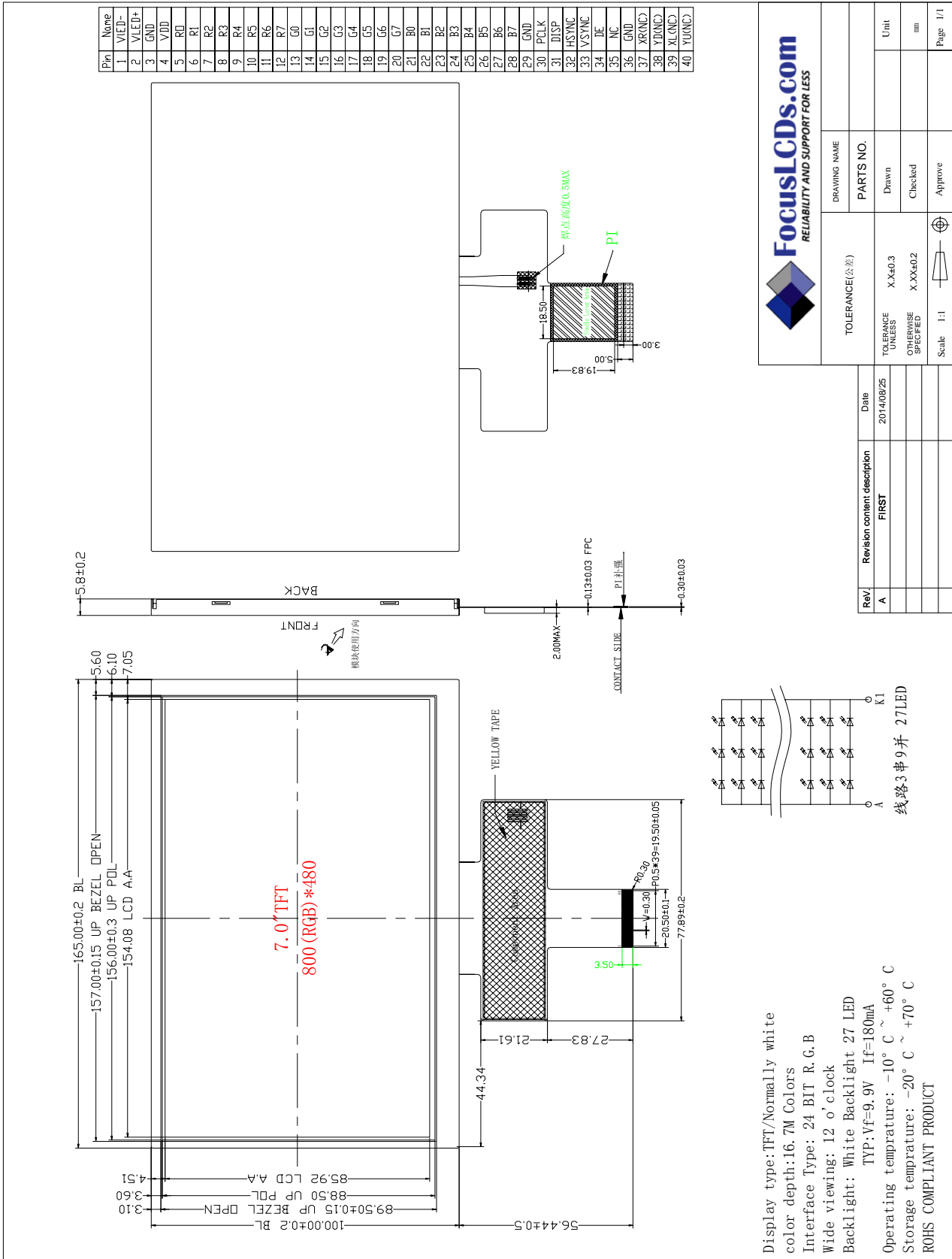

3. Input terminal Pin Assignment

NO.	SYMBOL	DISCRIPTION	I/O
1	VLED-	Cathode pin OF backlight	P
2	VLED+	Anode pin of backlight	P
3	GND	Ground.	P
4	VDD	Supply voltage(3.3V).	P
5	R0	Red data input.	I/O
6	R1	Red data input.	I/O
7	R2	Red data input.	I/O
8	R3	Red data input.	I/O
9	R4	Red data input.	I/O
10	R5	Red data input.	I/O
11	R6	Red data input.	I/O
12	R8	Red data input.	I/O
13	G0	Green data input.	I/O
14	G1	Green data input.	I/O
15	G2	Green data input.	I/O
16	G3	Green data input.	I/O
17	G4	Green data input.	I/O
18	G5	Green data input.	I/O
19	G6	Green data input.	I/O
20	G7	Green data input.	I/O
21	B0	Blue data input.	I/O
22	B1	Blue data input.	I/O
23	B2	Blue data input.	I/O
24	B3	Blue data input.	I/O
25	B4	Blue data input.	I/O
26	B5	Blue data input.	I/O

27	B6	Blue data input.	I/O
28	B7	Blue data input.	I/O
29	GND	Ground.	P
30	PCLK	Dot clock signal for RGB interface operation Fix this pin at VCI or GND when not in use.	I
31	DISP	Standby setting for testing, it should be connected to VDDIO in normal operation mode. If connected to GND, the IC is in standby mode.	I
32	HSYNC	Line synchronizing signal for RGB interface operation. fix this pin at VCI or GND when not in use	I
33	VSYNC	Frame synchronizing signal for RGB interface operation. fix this pin at VCI or GND when not in use.	I
34	DE	Data enable signal for RGB interface operation. fix this pin at VCI or GND when not in use.	I
35	NC	NC	
36	GND	Ground.	P
37	XR(NC)	Touch panel Right Glass Terminal	A/D
38	YD(NC)	Touch panel Bottom Film Terminal	A/D
39	XL(NC)	Touch panel LIFT Glass Terminal	A/D
40	YU(NC)	Touch panel Top Film Terminal	A/D

4. LCD Optical Characteristics

4.1 Optical specification

Item	Symbol	Condition	Values			Unit	Remark
			Min.	Typ.	Max.		
Viewing angle (CR≥10)	θ_L	$\Phi=180^\circ$ (9 o'clock)	60	70	-	degree	Note 1
	θ_R	$\Phi=0^\circ$ (3 o'clock)	60	70	-		
	θ_T	$\Phi=90^\circ$ (12 o'clock)	40	50	-		
	θ_B	$\Phi=270^\circ$ (6 o'clock)	60	70	-		
Response time	T_{ON}	Normal $\theta=\Phi=0^\circ$	-	10	20	msec	Note 3
	T_{OFF}		-	15	30	msec	Note 3
Contrast ratio	CR		400	500	-	-	Note 4
Color chromaticity	W_X		0.26	0.31	0.36	-	Note 2 Note 5
	W_Y	0.28	0.33	0.38	-		
Transmittance	$T\%$		-	5.11	-	-	-

Test Conditions:

1. $V_{CC}=3.3V$, $AV_{DD}=10V$, the ambient temperature is $25^\circ C$.
2. The test systems refer to Note 2.

Note 1: Definition of viewing angle range

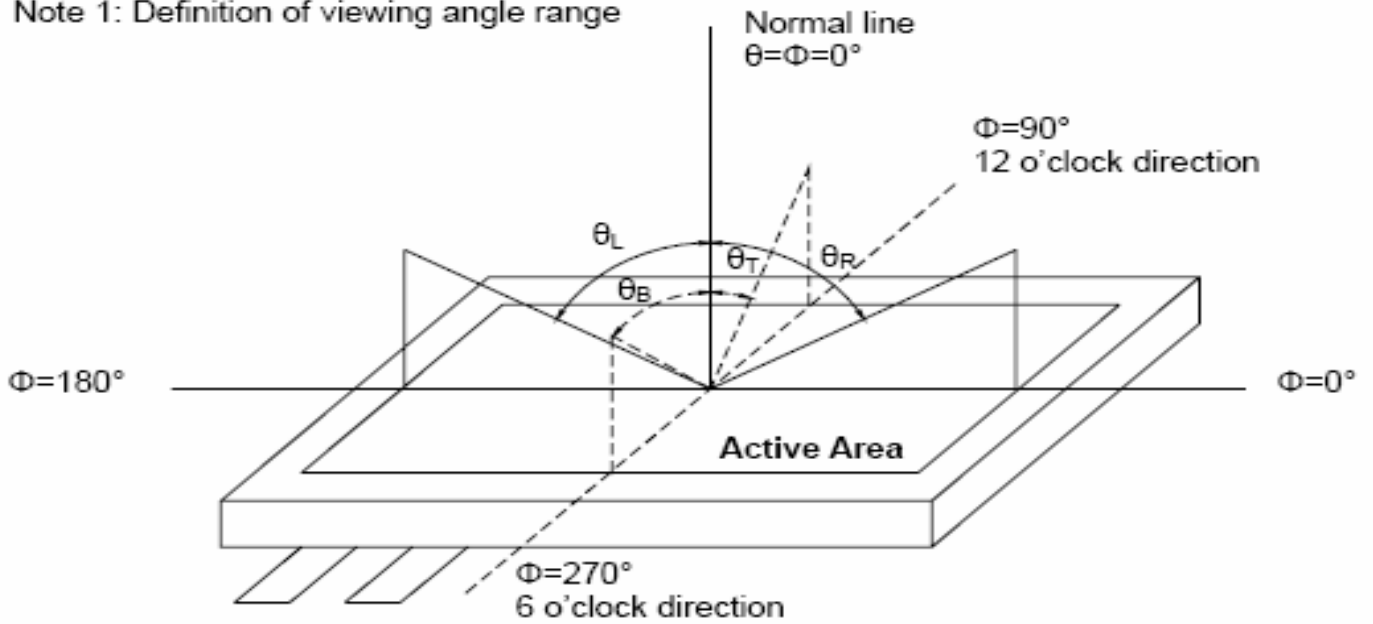

Fig. 4-1 Definition of viewing angle

Note 2: Definition of optical measurement system.

The optical characteristics should be measured in dark room. The optical properties are measured at the center point of the LCD screen. (Response time is measured by Photo detector TOPCON BM-7, other items are measured by BM-5A/Field of view: 1° /Height: 500mm.)

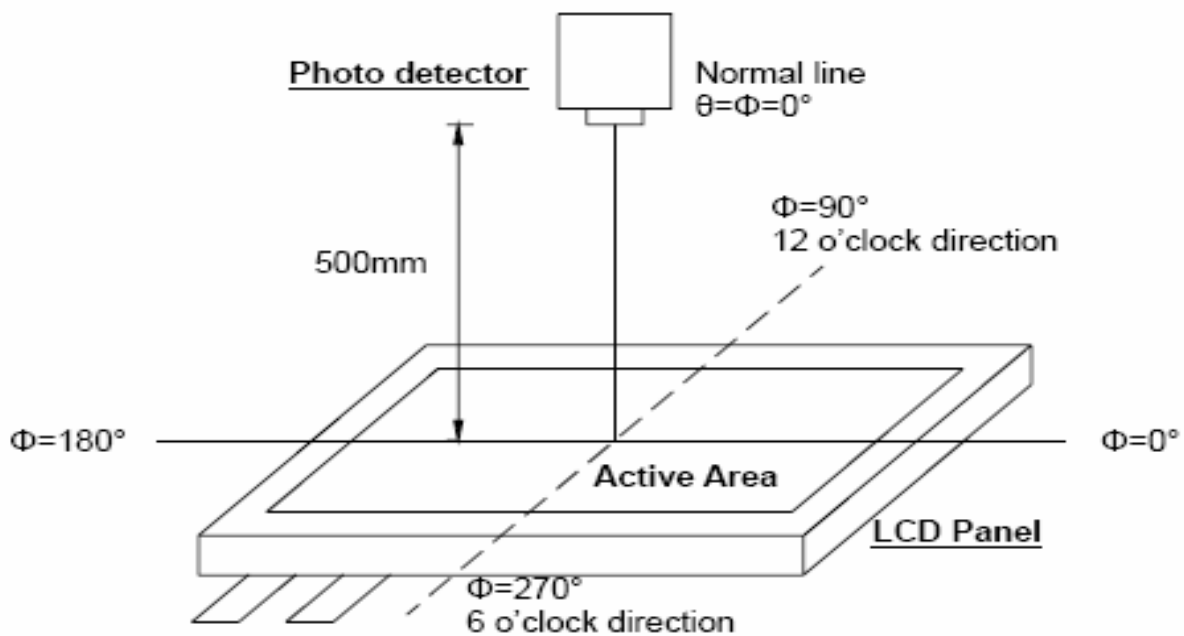

Fig. 4-2 Optical measurement system setup

The copyright belongs to InnoLux. Any unauthorized use is prohibited.

Note 3: Definition of Response time

The response time is defined as the LCD optical switching time interval between "White" state and "Black" state. Rise time (T_{ON}) is the time between photo detector output intensity changed from 90% to 10%. And fall time (T_{OFF}) is the time between photo detector output intensity changed from 10% to 90%.

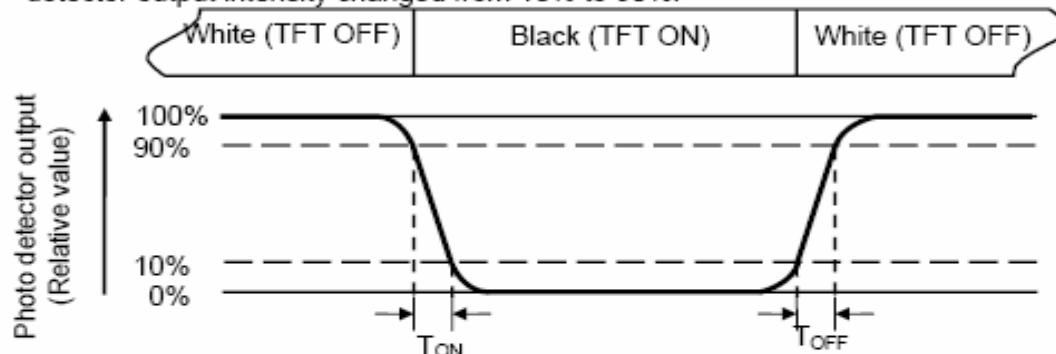

Fig. 4-3 Definition of response time

Note 4: Definition of contrast ratio

$$\text{Contrast ratio (CR)} = \frac{\text{Luminance measured when LCD on the "White" state}}{\text{Luminance measured when LCD on the "Black" state}}$$

Note 5: Definition of color chromaticity (CIE1931)

Color coordinates measured at center point of LCD.

5. Electrical Characteristics

5.1 Absolute Maximum Rating (Ta=25 VSS=0V)

Characteristics	Symbol	Min.	Max.	Unit
Digital Supply Voltage	VDD	-0.5	5.0	V
Digital interface supply Voltage	VDDIO	-0.5	VDD+0.3	V
Operating temperature	T _{OP}	-20	+70	°C
Storage temperature	T _{ST}	-30	+80	°C

5.2 DC Electrical Characteristics

Characteristics	Symbol	Min.	Typ.	Max.	Unit	Note
Digital Supply Voltage	VDD	3.0	3.3	3.6	V	
Digital interface supply Voltage	VDDIO	3.0	3.3	3.6	V	
Normal mode Current consumption	IDD	--	150	--	mA	
Level input voltage	V _{IH}	0.7VDDIO		VDDIO	V	
	V _{IL}	GND		0.3VDDIO	V	
Level output voltage	V _{OH}	0.8VDDIO		VDDIO	V	
	V _{OL}	GND		0.2VDDIO	V	

5.3 LED Backlight Characteristics

The back-light system is edge-lighting type with 27chips White LED

Item	Symbol	Min.	Typ.	Max.	Unit	Note
Forward Current	I_F	135	180	--	mA	
Forward Voltage	V_F	--	9.6	--	V	
LCM Luminance	L_V	450	--	--	cd/m ²	$I_F=180mA$
Uniformity	AV_g	80	--	--	%	

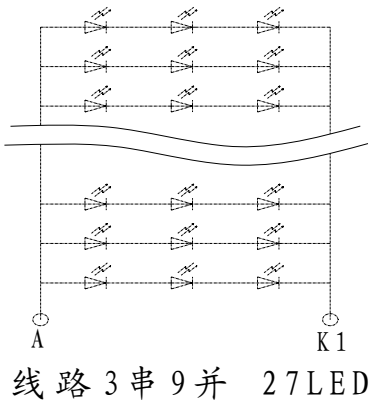

6. AC Characteristic

6.1. Display Timing characteristics

6.1.1 Vertical input timing

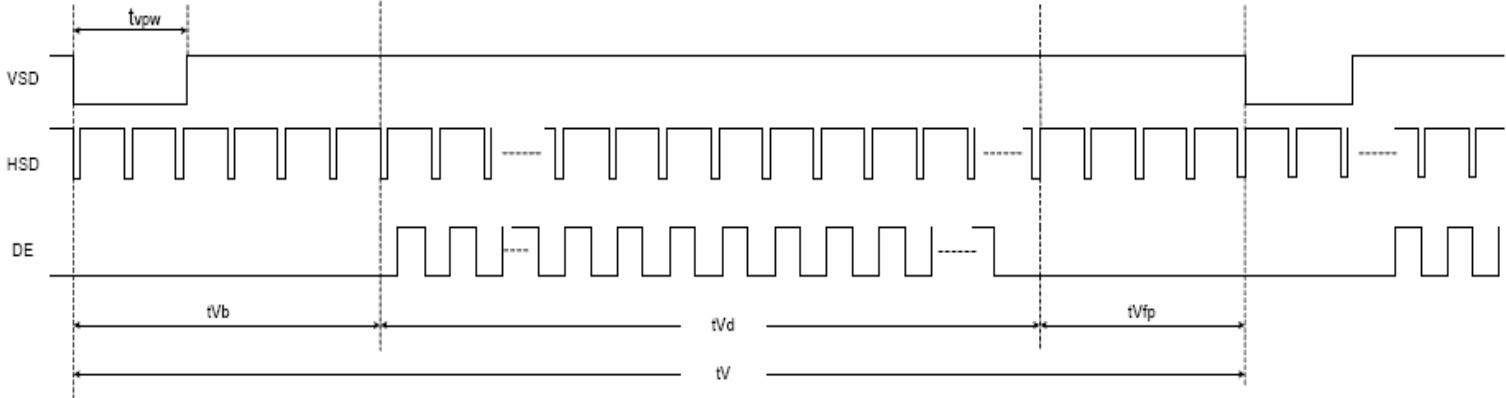

Parameter	Symbol	Min.	Typ.	Max.	Unit
Vertical display area	t_{vd}	480			H
VSD period time	t_v	510	525	650	H
VSD pulse width	t_{vpw}	1	-	20	H
VSD Back Porch (Blanking)	t_{vb}	23	23	23	H
VSD Front Porch	t_{vfp}	7	22	147	H

6.1.2 Horizontal input timing

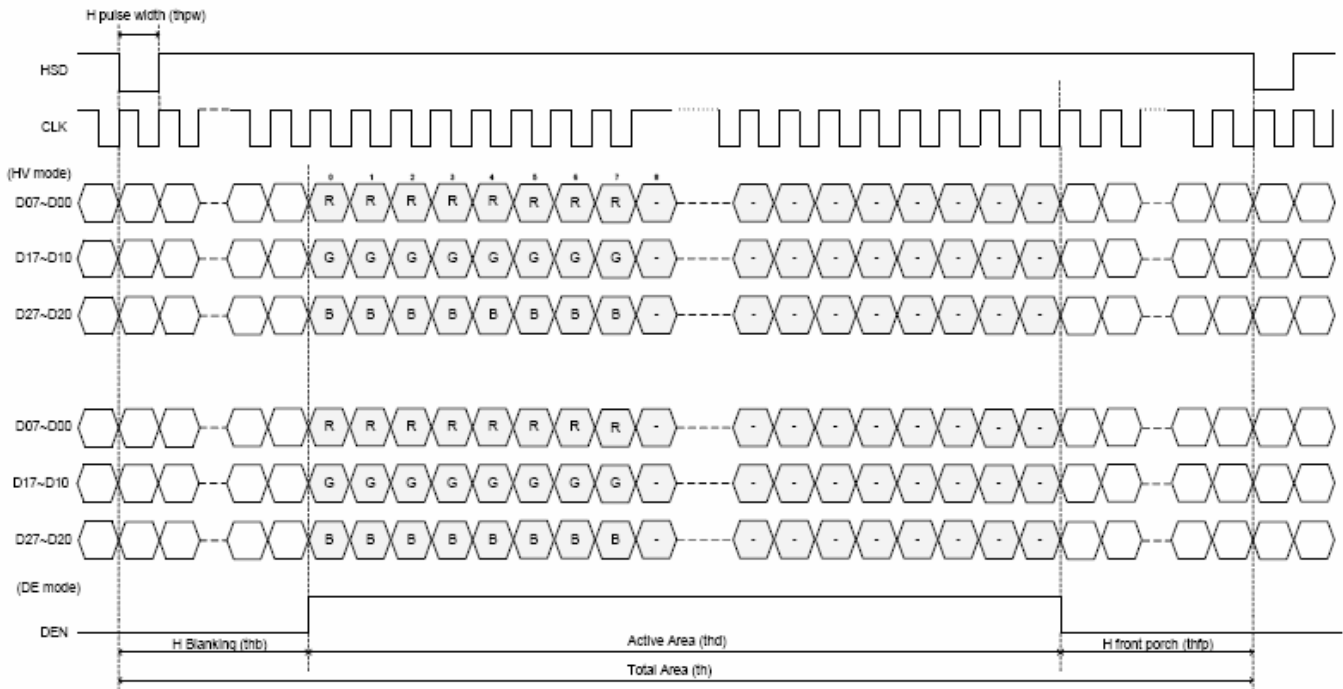

Parameter		Symbol	Value			Unit
Horizontal display area		thd	800			DCLK
DCLK frequency		fclk	Min.	Typ.	Max	MHz
			-	33.3	50	
1 Horizontal Line		th	862	1056	1200	DCLK
HSD pulse width		thpw	1			
			-			
			40			
HSD Back Porch (Blanking)		thb	46	46	46	
HSD Front Porch		thfp	16	210	354	

7. LCD Module Out-Going Quality Level

7.1 VISUAL & FUNCTION INSPECTION STANDARD

7.1.1 Inspection conditions

Inspection performed under the following conditions is recommended.

- Temperature : $25 \pm 5^{\circ}\text{C}$
- Humidity : $65\% \pm 10\% \text{RH}$
- Viewing Angle : Normal viewing Angle.
- Illumination: Single fluorescent lamp (300 to 700Lux)
- Viewing distance: 30–50cm

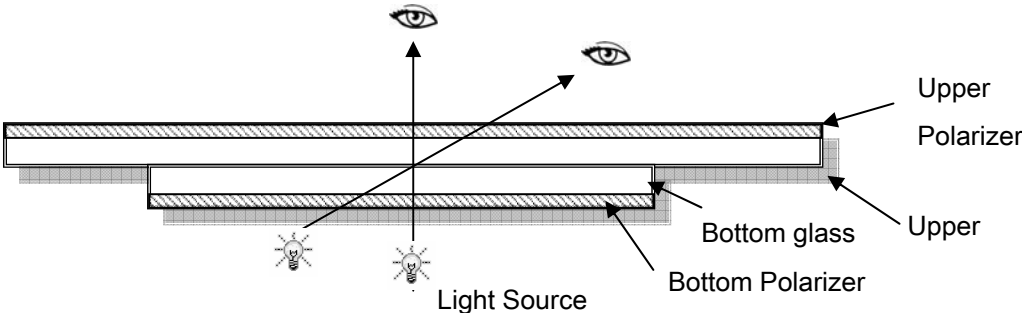

7.1.2 Definition

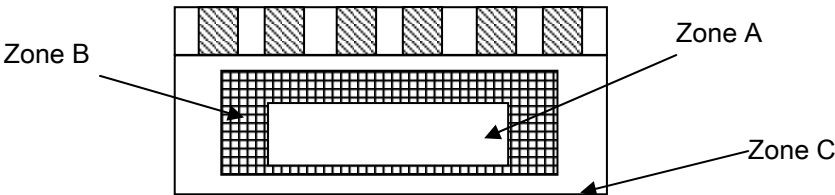

Zone A : Effective Viewing Area(Character or Digit can be seen)

Zone B : Viewing Area except Zone A

Zone C : Outside (Zone A+Zone B) which can not be seen after assembly by customer .)

Note:

As a general rule ,visual defects in Zone C can be ignored when it doesn't effect product function or appearance after assembly by customer.

7.1.3 Sampling Plan

According to GB/T 2828-2003 ; , normal inspection, Class II

AQL:

Major defect	Minor defect
0.65	1.5

LCD: Liquid Crystal Display , TP: Touch Panel , LCM: Liquid Crystal Module

No	Items to be inspected	Criteria	Classification of defects
1	Functional defects	1) No display, Open or miss line 2) Display abnormally, Short 3) Backlight no lighting, abnormal lighting. 4) TP no function	Major
2	Missing	Missing component	
3	Outline dimension	Overall outline dimension beyond the drawing is not allowed	
4	Color tone	Color unevenness, refer to limited sample	Minor
5	Soldering appearance	Good soldering , Peeling off is not allowed.	
6	LCD/Polarizer/TP	Black/White spot/line, scratch, crack, etc.	

7.1.4 Criteria (Visual)

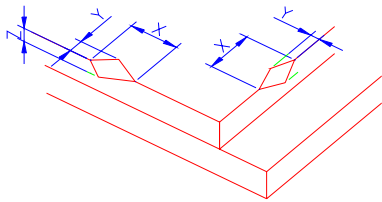
Number	Items	Criteria(mm)						
1.0 LCD Crack/Broken	(1) The edge of LCD broken							
NOTE: X: Length Y: Width		<table border="1"> <tr> <td>X</td> <td>Y</td> <td>Z</td> </tr> <tr> <td>≤3.0mm</td> <td><Inner border line of the seal</td> <td>≤T</td> </tr> </table>	X	Y	Z	≤3.0mm	<Inner border line of the seal	≤T
X	Y	Z						
≤3.0mm	<Inner border line of the seal	≤T						

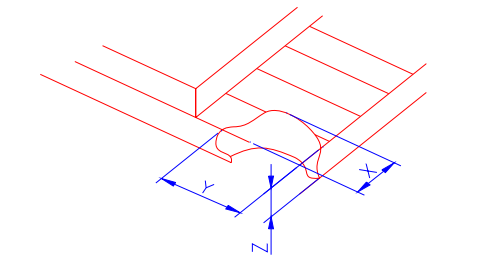
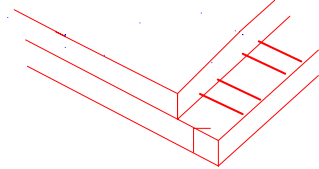
<p>Z: Height L: Length of ITO, T: Height of LCD</p>	<p>(2) LCD corner broken</p>	 <table border="1" data-bbox="805 548 1220 649"> <tr> <td>X</td> <td>Y</td> <td>Z</td> </tr> <tr> <td>≤3.0mm</td> <td>≤L</td> <td>≤T</td> </tr> </table>	X	Y	Z	≤3.0mm	≤L	≤T
X	Y	Z						
≤3.0mm	≤L	≤T						
	<p>(3) LCD crack</p>	 <p>Crack Not allowed</p>						

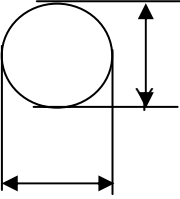
Number	Items	Criteria (mm)																																																																	
2.0	Spot defect  $\Phi = (X+Y)/2$	<p>① light dot (LCD/TP/Polarizer black/white spot , light dot, pinhole, dent, stain)</p> <table border="1" data-bbox="416 353 1345 712"> <thead> <tr> <th rowspan="2">Zone Size (mm)</th> <th colspan="3">Acceptable Qty</th> </tr> <tr> <th>A</th> <th>B</th> <th>C</th> </tr> </thead> <tbody> <tr> <td>$\Phi \leq 0.10$</td> <td colspan="3">Ignore</td> </tr> <tr> <td>$0.10 < \Phi \leq 0.15$</td> <td colspan="3">3(distance $\geq 10\text{mm}$)</td> </tr> <tr> <td>$0.15 < \Phi \leq 0.2$</td> <td colspan="3">1</td> </tr> <tr> <td>$0.2 < \Phi$</td> <td colspan="3">0</td> </tr> </tbody> </table> <p>② Dim spot (LCD/TP/Polarizer dim dot, light leakage, dark spot)</p> <table border="1" data-bbox="416 801 1370 1167"> <thead> <tr> <th rowspan="2">Zone Size (mm)</th> <th colspan="3">Acceptable Qty</th> </tr> <tr> <th>A</th> <th>B</th> <th>C</th> </tr> </thead> <tbody> <tr> <td>$\Phi \leq 0.1$</td> <td colspan="3">Ignore</td> </tr> <tr> <td>$0.1 < \Phi \leq 0.2$</td> <td colspan="3">2(distance $\geq 10\text{mm}$)</td> </tr> <tr> <td>$0.2 < \Phi \leq 0.3$</td> <td colspan="3">1</td> </tr> <tr> <td>$\Phi > 0.3$</td> <td colspan="3">0</td> </tr> </tbody> </table> <p>③ Polarizer accidented spot</p> <table border="1" data-bbox="416 1256 1370 1547"> <thead> <tr> <th rowspan="2">Zone Size (mm)</th> <th colspan="3">Acceptable Qty</th> </tr> <tr> <th>A</th> <th>B</th> <th>C</th> </tr> </thead> <tbody> <tr> <td>$\Phi \leq 0.2$</td> <td colspan="3">Ignore</td> </tr> <tr> <td>$0.2 < \Phi \leq 0.5$</td> <td colspan="3">2(distance $\geq 10\text{mm}$)</td> </tr> <tr> <td>$\Phi > 0.5$</td> <td colspan="3">0</td> </tr> </tbody> </table>	Zone Size (mm)	Acceptable Qty			A	B	C	$\Phi \leq 0.10$	Ignore			$0.10 < \Phi \leq 0.15$	3(distance $\geq 10\text{mm}$)			$0.15 < \Phi \leq 0.2$	1			$0.2 < \Phi$	0			Zone Size (mm)	Acceptable Qty			A	B	C	$\Phi \leq 0.1$	Ignore			$0.1 < \Phi \leq 0.2$	2(distance $\geq 10\text{mm}$)			$0.2 < \Phi \leq 0.3$	1			$\Phi > 0.3$	0			Zone Size (mm)	Acceptable Qty			A	B	C	$\Phi \leq 0.2$	Ignore			$0.2 < \Phi \leq 0.5$	2(distance $\geq 10\text{mm}$)			$\Phi > 0.5$	0		
Zone Size (mm)	Acceptable Qty																																																																		
	A	B	C																																																																
$\Phi \leq 0.10$	Ignore																																																																		
$0.10 < \Phi \leq 0.15$	3(distance $\geq 10\text{mm}$)																																																																		
$0.15 < \Phi \leq 0.2$	1																																																																		
$0.2 < \Phi$	0																																																																		
Zone Size (mm)	Acceptable Qty																																																																		
	A	B	C																																																																
$\Phi \leq 0.1$	Ignore																																																																		
$0.1 < \Phi \leq 0.2$	2(distance $\geq 10\text{mm}$)																																																																		
$0.2 < \Phi \leq 0.3$	1																																																																		
$\Phi > 0.3$	0																																																																		
Zone Size (mm)	Acceptable Qty																																																																		
	A	B	C																																																																
$\Phi \leq 0.2$	Ignore																																																																		
$0.2 < \Phi \leq 0.5$	2(distance $\geq 10\text{mm}$)																																																																		
$\Phi > 0.5$	0																																																																		
	Line defect (LCD/TP /Polarizer black/white line, scratch, stain)	<table border="1" data-bbox="416 1592 1362 1962"> <thead> <tr> <th rowspan="2">Width(mm)</th> <th rowspan="2">Length(mm)</th> <th colspan="3">Acceptable Qty</th> </tr> <tr> <th>A</th> <th>B</th> <th>C</th> </tr> </thead> <tbody> <tr> <td>$\Phi \leq 0.03$</td> <td>Ignore</td> <td colspan="2">Ignore</td> <td rowspan="3">Ignore</td> </tr> <tr> <td>$0.03 < W \leq 0.05$</td> <td>$L \leq 3.0$</td> <td colspan="2">$N \leq 2$</td> </tr> <tr> <td>$0.05 < W \leq 0.08$</td> <td>$L \leq 2.0$</td> <td colspan="2">$N \leq 2$</td> </tr> <tr> <td>$0.08 < W$</td> <td colspan="4">Define as spot defect</td> </tr> </tbody> </table>	Width(mm)	Length(mm)	Acceptable Qty			A	B	C	$\Phi \leq 0.03$	Ignore	Ignore		Ignore	$0.03 < W \leq 0.05$	$L \leq 3.0$	$N \leq 2$		$0.05 < W \leq 0.08$	$L \leq 2.0$	$N \leq 2$		$0.08 < W$	Define as spot defect																																										
Width(mm)	Length(mm)	Acceptable Qty																																																																	
		A	B	C																																																															
$\Phi \leq 0.03$	Ignore	Ignore		Ignore																																																															
$0.03 < W \leq 0.05$	$L \leq 3.0$	$N \leq 2$																																																																	
$0.05 < W \leq 0.08$	$L \leq 2.0$	$N \leq 2$																																																																	
$0.08 < W$	Define as spot defect																																																																		

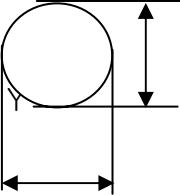
Items	Criteria (mm)																																																																	
Spot defect  $\Phi = (X+Y)/2$	<p>① light dot (LCD/TP/Polarizer black/white spot , light dot, pinhole, dent, stain)</p> <table border="1" data-bbox="416 745 1342 1095"> <thead> <tr> <th rowspan="2">Zone Size (mm)</th> <th colspan="3">Acceptable Qty</th> </tr> <tr> <th>A</th> <th>B</th> <th>C</th> </tr> </thead> <tbody> <tr> <td>$\Phi \leq 0.10$</td> <td colspan="3">Ignore</td> </tr> <tr> <td>$0.10 < \Phi \leq 0.15$</td> <td colspan="3">3(distance $\geq 10\text{mm}$)</td> </tr> <tr> <td>$0.15 < \Phi \leq 0.2$</td> <td colspan="3">1</td> </tr> <tr> <td>$0.2 < \Phi$</td> <td colspan="3">0</td> </tr> </tbody> </table> <p>② Dim spot (LCD/TP/Polarizer dim dot, light leakage, dark spot)</p> <table border="1" data-bbox="416 1189 1369 1547"> <thead> <tr> <th rowspan="2">Zone Size (mm)</th> <th colspan="3">Acceptable Qty</th> </tr> <tr> <th>A</th> <th>B</th> <th>C</th> </tr> </thead> <tbody> <tr> <td>$\Phi \leq 0.1$</td> <td colspan="3">Ignore</td> </tr> <tr> <td>$0.1 < \Phi \leq 0.2$</td> <td colspan="3">2(distance $\geq 10\text{mm}$)</td> </tr> <tr> <td>$0.2 < \Phi \leq 0.3$</td> <td colspan="3">1</td> </tr> <tr> <td>$\Phi > 0.3$</td> <td colspan="3">0</td> </tr> </tbody> </table> <p>③ Polarizer accidented spot</p> <table border="1" data-bbox="416 1641 1230 1942"> <thead> <tr> <th rowspan="2">Zone Size (mm)</th> <th colspan="3">Acceptable Qty</th> </tr> <tr> <th>A</th> <th>B</th> <th>C</th> </tr> </thead> <tbody> <tr> <td>$\Phi \leq 0.2$</td> <td colspan="3">Ignore</td> </tr> <tr> <td>$0.2 < \Phi \leq 0.5$</td> <td colspan="3">2(distance $\geq 10\text{mm}$)</td> </tr> <tr> <td>$\Phi > 0.5$</td> <td colspan="3">0</td> </tr> </tbody> </table>	Zone Size (mm)	Acceptable Qty			A	B	C	$\Phi \leq 0.10$	Ignore			$0.10 < \Phi \leq 0.15$	3(distance $\geq 10\text{mm}$)			$0.15 < \Phi \leq 0.2$	1			$0.2 < \Phi$	0			Zone Size (mm)	Acceptable Qty			A	B	C	$\Phi \leq 0.1$	Ignore			$0.1 < \Phi \leq 0.2$	2(distance $\geq 10\text{mm}$)			$0.2 < \Phi \leq 0.3$	1			$\Phi > 0.3$	0			Zone Size (mm)	Acceptable Qty			A	B	C	$\Phi \leq 0.2$	Ignore			$0.2 < \Phi \leq 0.5$	2(distance $\geq 10\text{mm}$)			$\Phi > 0.5$	0		
Zone Size (mm)	Acceptable Qty																																																																	
	A	B	C																																																															
$\Phi \leq 0.10$	Ignore																																																																	
$0.10 < \Phi \leq 0.15$	3(distance $\geq 10\text{mm}$)																																																																	
$0.15 < \Phi \leq 0.2$	1																																																																	
$0.2 < \Phi$	0																																																																	
Zone Size (mm)	Acceptable Qty																																																																	
	A	B	C																																																															
$\Phi \leq 0.1$	Ignore																																																																	
$0.1 < \Phi \leq 0.2$	2(distance $\geq 10\text{mm}$)																																																																	
$0.2 < \Phi \leq 0.3$	1																																																																	
$\Phi > 0.3$	0																																																																	
Zone Size (mm)	Acceptable Qty																																																																	
	A	B	C																																																															
$\Phi \leq 0.2$	Ignore																																																																	
$0.2 < \Phi \leq 0.5$	2(distance $\geq 10\text{mm}$)																																																																	
$\Phi > 0.5$	0																																																																	

Line defect (LCD/TP /Polarizer black/white line, scratch, stain)	<table border="1"> <thead> <tr> <th rowspan="2">Width(mm)</th> <th rowspan="2">Length(mm)</th> <th colspan="3">Acceptable Qty</th> </tr> <tr> <th>A</th> <th>B</th> <th>C</th> </tr> </thead> <tbody> <tr> <td>$\Phi \leq 0.03$</td> <td>Ignore</td> <td colspan="2">Ignore</td> <td rowspan="3">Ignore</td> </tr> <tr> <td>$0.03 < W \leq 0.05$</td> <td>$L \leq 3.0$</td> <td colspan="2">$N \leq 2$</td> </tr> <tr> <td>$0.05 < W \leq 0.08$</td> <td>$L \leq 2.0$</td> <td colspan="2">$N \leq 2$</td> </tr> <tr> <td>$0.08 < W$</td> <td colspan="3">Define as spot defect</td> <td></td> </tr> </tbody> </table>	Width(mm)	Length(mm)	Acceptable Qty			A	B	C	$\Phi \leq 0.03$	Ignore	Ignore		Ignore	$0.03 < W \leq 0.05$	$L \leq 3.0$	$N \leq 2$		$0.05 < W \leq 0.08$	$L \leq 2.0$	$N \leq 2$		$0.08 < W$	Define as spot defect			
	Width(mm)			Length(mm)	Acceptable Qty																						
A		B	C																								
$\Phi \leq 0.03$	Ignore	Ignore		Ignore																							
$0.03 < W \leq 0.05$	$L \leq 3.0$	$N \leq 2$																									
$0.05 < W \leq 0.08$	$L \leq 2.0$	$N \leq 2$																									
$0.08 < W$	Define as spot defect																										
Polarizer Bubble	<table border="1"> <thead> <tr> <th rowspan="2">Zone Size (mm)</th> <th colspan="3">Acceptable Qty</th> </tr> <tr> <th>A</th> <th>B</th> <th>C</th> </tr> </thead> <tbody> <tr> <td>$\Phi \leq 0.2$</td> <td colspan="2">Ignore</td> <td rowspan="4">Ignore</td> </tr> <tr> <td>$0.2 < \Phi \leq 0.4$</td> <td colspan="2">2(distance $\geq 10\text{mm}$)</td> </tr> <tr> <td>$0.4 < \Phi \leq 0.6$</td> <td colspan="2">1</td> </tr> <tr> <td>$0.6 < \Phi$</td> <td colspan="2">0</td> </tr> </tbody> </table>	Zone Size (mm)	Acceptable Qty			A	B	C	$\Phi \leq 0.2$	Ignore		Ignore	$0.2 < \Phi \leq 0.4$	2(distance $\geq 10\text{mm}$)		$0.4 < \Phi \leq 0.6$	1		$0.6 < \Phi$	0							
Zone Size (mm)	Acceptable Qty																										
	A	B	C																								
$\Phi \leq 0.2$	Ignore		Ignore																								
$0.2 < \Phi \leq 0.4$	2(distance $\geq 10\text{mm}$)																										
$0.4 < \Phi \leq 0.6$	1																										
$0.6 < \Phi$	0																										
SMT	According to IPC-A-610C class II standard . Function defect and missing part are major defect ,the others are minor defect.																										

TP bubble/ accidented spot	<table border="1"> <thead> <tr> <th rowspan="2">Size Φ(mm)</th> <th colspan="3">Acceptable Qty</th> </tr> <tr> <th>A</th> <th>B</th> <th>C</th> </tr> </thead> <tbody> <tr> <td>$\Phi \leq 0.1$</td> <td colspan="2">Ignore</td> <td rowspan="4">Ignore</td> </tr> <tr> <td>$0.1 < \Phi \leq 0.2$</td> <td colspan="2">2</td> </tr> <tr> <td>$0.2 < \Phi \leq 0.3$</td> <td colspan="2">1</td> </tr> <tr> <td>$0.3 < \Phi$</td> <td colspan="2">0</td> </tr> </tbody> </table>	Size Φ (mm)	Acceptable Qty			A	B	C	$\Phi \leq 0.1$	Ignore		Ignore	$0.1 < \Phi \leq 0.2$	2		$0.2 < \Phi \leq 0.3$	1		$0.3 < \Phi$	0	
	Size Φ (mm)		Acceptable Qty																		
A		B	C																		
$\Phi \leq 0.1$	Ignore		Ignore																		
$0.1 < \Phi \leq 0.2$	2																				
$0.2 < \Phi \leq 0.3$	1																				
$0.3 < \Phi$	0																				
Assembly deflection	beyond the edge of backlight $\leq 0.15\text{mm}$																				

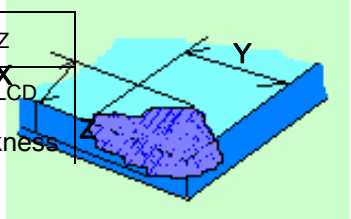
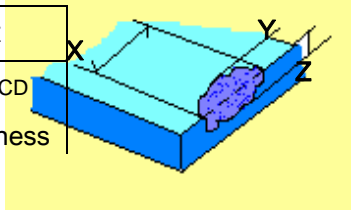
5.0	TP Related	Newton Ring	<p>Newton area > 1/3 TP Ring area NG</p> <p>Newton area ≤ 1/3 TP Ring area OK</p>							
		TP corner broken X : length Y : width Z : height	<table border="1" data-bbox="687 1099 986 1249"> <tr> <th>X</th> <th>Y</th> <th>Z</th> </tr> <tr> <td>$X \leq 3.0\text{mm}$</td> <td>$Y \leq 3.0\text{mm}$</td> <td>$Z < \text{LCD thickness}$</td> </tr> </table> <p>* Circuitry broken is not allowed.</p>	X	Y	Z	$X \leq 3.0\text{mm}$	$Y \leq 3.0\text{mm}$	$Z < \text{LCD thickness}$	
X	Y	Z								
$X \leq 3.0\text{mm}$	$Y \leq 3.0\text{mm}$	$Z < \text{LCD thickness}$								
		TP edge broken X : length Y : width Z : height	<table border="1" data-bbox="687 1435 986 1585"> <tr> <th>X</th> <th>Y</th> <th>Z</th> </tr> <tr> <td>$X \leq 6.0\text{mm}$</td> <td>$Y \leq 2.0\text{mm}$</td> <td>$Z < \text{LCD thickness}$</td> </tr> </table> <p>* Circuitry broken is not allowed.</p>	X	Y	Z	$X \leq 6.0\text{mm}$	$Y \leq 2.0\text{mm}$	$Z < \text{LCD thickness}$	
X	Y	Z								
$X \leq 6.0\text{mm}$	$Y \leq 2.0\text{mm}$	$Z < \text{LCD thickness}$								

Criteria (functional items)

Number	Items	Criteria (mm)
1	No display	Not allowed
2	Missing segment	Not allowed
3	Short	Not allowed
4	Backlight no lighting	Not allowed
5	TP no function	Not allowed

8. Reliability Test Result

8.1 Condition

Item	Condition	Sample Size	Test Result	Note
Low Temperature Operating Life test	-20°C, 96HR	3ea	pass	-
Thermal Humidity Operating Life test	70°C 90%RH, 96HR	3ea	pass	-
Temperature Cycle ON/OFF test	-20°C ↔ 70°C, ON/OFF, 20CYC	3ea	pass	(1)
High Temperature Storage test	80°C, 96HR	3ea	pass	-
Low Temperature Storage test	- 30°C, 96HR	3ea	pass	-
Thermal Shock Resistance	The sample should be allowed to stand the following 5 cycles of operation: TSTL for 30 minutes -> normal temperature for 5 minutes -> TSTH for 30 minutes -> normal temperature for 5 minutes, as one cycle, then taking it out and drying it at normal temperature, and allowing it stand for 24 hours	3ea	pass	
Box Drop Test	1 Corner 3 Edges 6 faces, 66cm(MEDIUM BOX)	1 box	pass	-

Note (1) ON Time over 10 seconds, OFF Time under 10 seconds

9. Cautions and Handling Precautions

9.1 Handling and Operating the Module

(1) When the module is assembled, it should be attached to the system firmly.

Do not warp or twist the module during assembly work.

(2) Protect the module from physical shock or any force. In addition to damage, this may cause improper operation or damage to the module and back-light unit.

(3) Note that polarizer is very fragile and could be easily damaged. Do not press or scratch the surface.

(4) Do not allow drops of water or chemicals to remain on the display surface.

If you have the droplets for a long time, staining and discoloration may occur.

(5) If the surface of the polarizer is dirty, clean it using some absorbent cotton or soft cloth.

(6) The desirable cleaners are water, IPA (Isopropyl Alcohol) or Hexane.

Do not use ketene type materials (ex. Acetone), Ethyl alcohol, Toluene, Ethyl acid or Methyl chloride. It might permanent damage to the polarizer due to chemical reaction.

(7) If the liquid crystal material leaks from the panel, it should be kept away from the eyes or mouth. In case of contact with hands, legs, or clothes, it must be washed away thoroughly with soap.

(8) Protect the module from static; it may cause damage to the CMOS ICs.

(9) Use finger-stalls with soft gloves in order to keep display clean during the incoming inspection and assembly process.

(10) Do not disassemble the module.

(11) Protection film for polarizer on the module shall be slowly peeled off just before use so that the electrostatic charge can be minimized.

(12) Pins of I/F connector shall not be touched directly with bare hands.

(13) Do not connect, disconnect the module in the "Power ON" condition.

(14) Power supply should always be turned on/off by the item 6.1 Power On Sequence & 6.2 Power Off Sequence

9.2 Storage and Transportation.

(1) Do not leave the panel in high temperature, and high humidity for a long time.

It is highly recommended to store the module with temperature from 0 to 35 °C and relative humidity of less than 70%

(2) Do not store the TFT-LCD module in direct sunlight.

(3) The module shall be stored in a dark place. When storing the modules for a long time, be sure to adopt effective measures for protecting the modules from strong ultraviolet radiation, sunlight, or fluorescent light.

(4) It is recommended that the modules should be stored under a condition where no condensation is allowed. Formation of dewdrops may cause an abnormal operation or a failure of the module.

In particular, the greatest possible care should be taken to prevent any module from being operated where condensation has occurred inside.

(5) This panel has its circuitry FPC on the bottom side and should be handled carefully in order not to be stressed.