

High-Precision Fiber-optic Amplifier

E3X-NH

The E3X-NH Employs a 16-Bit Processor as *An Industry First*

- An Automatic Sensitivity Adjustment feature allows stable detection of objects in frequently changing environments
- Three teach modes for optimal sensing
- 8-point scaled sensitivity meter is ideal for high precision sensing and through-beam applications at long distances (and clearly displays a target's reflectivity level)
- A manual fine tuning sensitivity feature allows 13 threshold adjustments using an easy-to-read digital scale
- Ideal for detecting small objects or fine wires
- NPN/PNP types available



Ordering Information

■ AMPLIFIER UNITS

Description		General-purpose models		Timer-function models	
Output		NPN	PNP	NPN	PNP
Part number		E3X-NH11	E3X-NH41	E3X-NH21	E3X-NH51
Appearance					
Light source (Wave length)		Red LED (680 nm)			
Power supply voltage		12 to 24 VDC ±10%, ripple (p-p) 10% max.			
Current consumption		75 mA max.			
Output	Control output	NPN open collector, load current: 50 mA max., residual voltage: 1 V max.	PNP open collector, load current: 50 mA max., residual voltage: 1 V max.	NPN open collector, load current: 50 mA max., residual voltage: 1 V max.	PNP open collector, load current: 50 mA max., residual voltage: 1 V max.
	Alarm output	1 V max.	1 V max.	1 V max.	1 V max.
Response time		1 ms max. for turn-on and turn-off, respectively			
Sensitivity setting		Teaching method			
Fine sensitivity adjustment		Automatic or manual fine threshold adjustment (13 levels)			

Specifications

Description		General-purpose models	Timer-function models		
Part number		E3X-NH11	E3X-NH41	E3X-NH21	E3X-NH51
Light source		Red (680 nm)			
Supply voltage		12-24 VDC +10% ripple (p-p) 10 % max.			
Output		NPN	PNP	NPN	PNP
Timing		—		40 ms off delay	
Indicator		Operation indicator (orange LED), 8-level incident level indicator (green LED), 13-level threshold indicator (red LED)			
Circuit protection		Output short-circuit protection, reverse polarity on supply			
Operation mode		Light ON and Dark ON, switch-selectable			
Ambient light immunity	Incandescent lamp	3,000 lx max.			
	Sunlight	10,000 lx max.			
Ambient temperature	Operating	-25°C to 55°C (-13°F to 131°F) with no icing			
	Storage	-40°C to 70°C (-40°F to 158°F) with no icing			
Ambient humidity	Operating	35% to 85% (with no condensation)			
Dielectric strength		1,000 VAC at 50/60 Hz for 1 minute			
Vibration resistance		10 to 55 Hz, 1.5-mm double amplitude or 300 m/s ² (approx. 30G) for 2 hrs each in X, Y, and Z directions			
Insulation resistance		20 MΩ min. (at 500 VDC)			
Shock resistance		500 m/s ² (approx. 50G) for 3 times each in X, Y, and Z axis			
Enclosure rating		IEC IP50			
Connection method		2m cable			
Material	Case	PBT			
	Cover	Polycarbonate			
Weight (with 2 m cable)		Approx. 100 g			
Accessory		Mounting brackets (included)			

Nomenclature

E3X-NH11

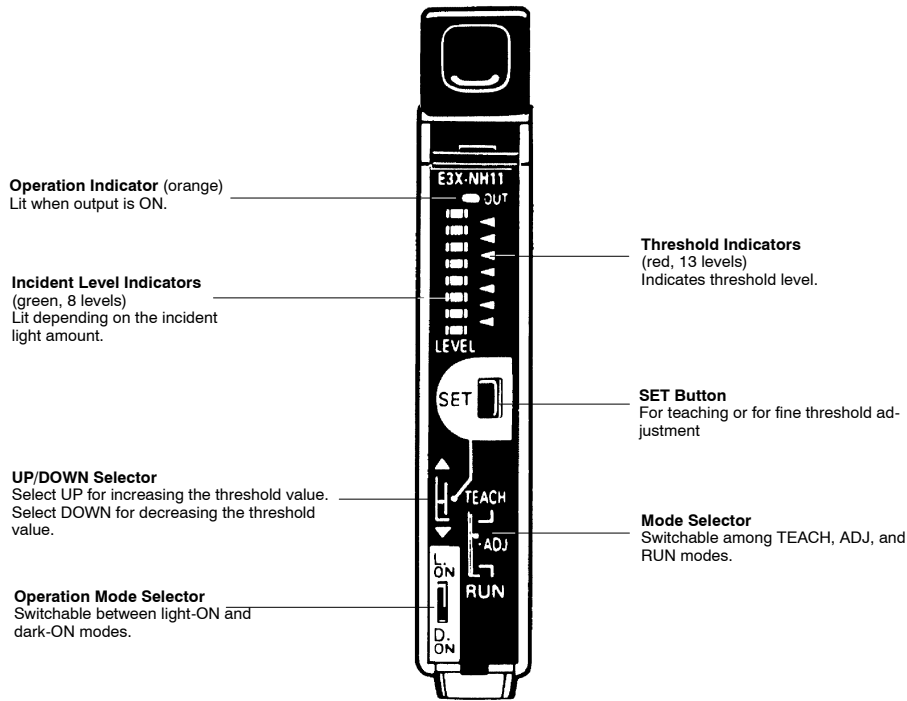

Operation

OUTPUT CIRCUITS

E3X-NH11 (NPN output)

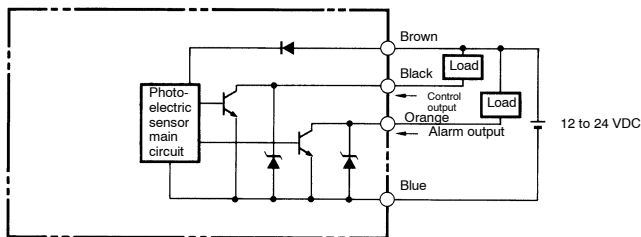

PNP circuits

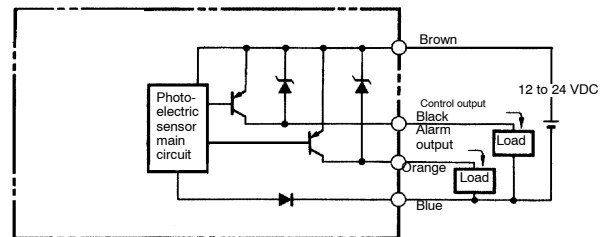

OPERATION MODE

Light-ON		Dark-ON	
Light received		Light received	
Light not received		Light not received	
Operation indicator (orange)	ON	Operation indicator (orange)	ON
	OFF		OFF
Output transistor	ON	Output transistor	ON
	OFF		OFF
Load (relay)	Operate	Load (relay)	Operate
	Release		Release
(Between brown and black)		(Between brown and black)	

SENSITIVITY SETTING AND ADJUSTMENT

Refer to the following to select the most suitable sensitivity setting method. We recommend that two-point teaching and manual-tuning be tried first.

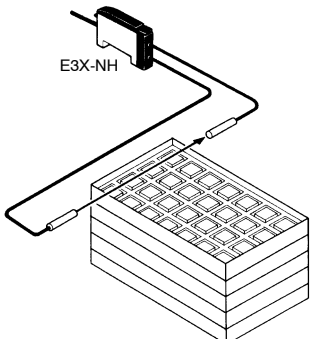
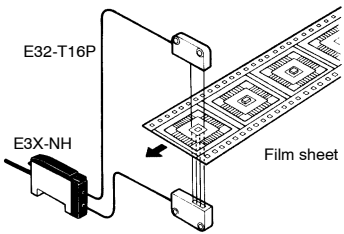
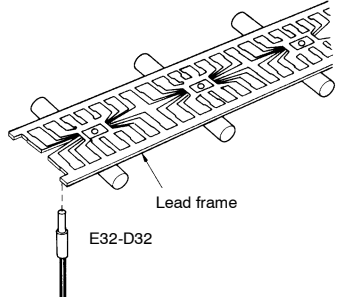
Sensitivity Setting	<p>Using the Sensor at the Maximum Sensitivity</p> <p>Application Examples Detection of a passing object with through-beam fibers.</p> <p>Checking IC Tray Arrangements</p> 	<p>Sensing Slight Differences</p> <p>Application Examples Detection of slight differences in reflection. Detection of translucent objects. Detection of object surface irregularities. Color discrimination.</p> <p>Detecting IC Chips on Film Sheet</p> 	<p>Sensitivity Setting Without Objects</p> <p>Application Examples Detection of minute passing objects. Detection of lead wires. High-precision positioning.</p> <p>Detecting Lead Frame Position</p> 
	Maximum Sensitivity Setting	Two-point Teach Mode	One-point Teach Mode

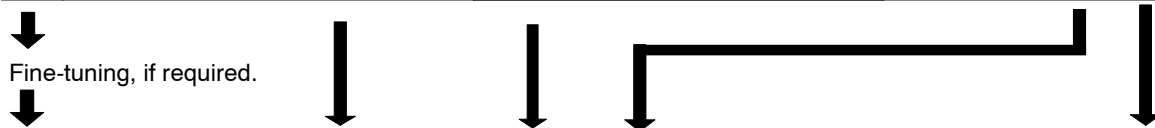

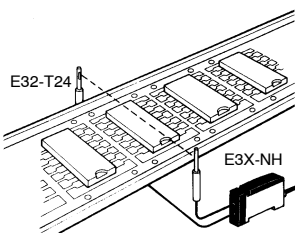
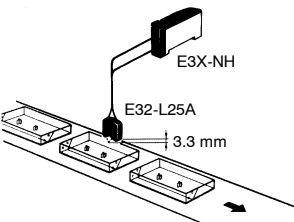
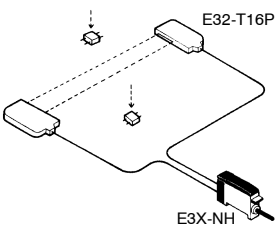
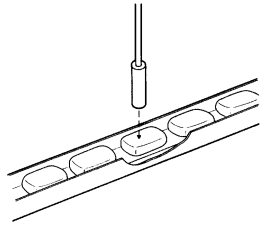
Sensitivity Adjustment (Fine-tuning)	<p>Fine-tuning on Production Lines</p> <p>Reason Marginal sensitivity adjustment is required considering the differences in targets. For high-precision positioning of electronic parts.</p> <p>Detecting Lead Frame Rises</p>  <p>Detecting Cassette Tape Cases Ensuring reliable detection without being influenced by the difference in color or mark.</p> 	<p>Ideal Operation Under Frequently Changing Environments</p> <p>Reason Dust sticking to the fiber tip. Targets are slightly different from each other in color or surface quality.</p> <p>Detecting Passing Chip Parts</p>  <p>Counting Number Of Pills</p> 
	Manual-tuning (Fine Sensitivity Adjustment)	Auto-tuning (Automatic Sensitivity Compensation)

■ SENSITIVITY SETTING (TEACHING)

The sensitivity of the E3X-NH is factory-set to maximum. When resetting the sensitivity of the E3X-NH to maximum after with/without-object teaching or positioning/no-object teaching, follow the steps described below.

Maximum Sensitivity Setting

1. Set the mode selector to TEACH.
Hold the SET button down for three seconds. Be sure that all the threshold indicators (red) are lit. The built-in buzzer will beep once when the threshold indicator is lit.

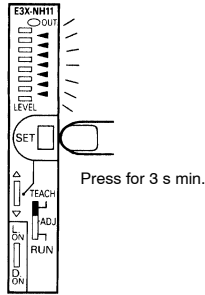

2. The sensitivity will be set when the built-in buzzer beeps continuously and all the incident level indicators (green) are lit.

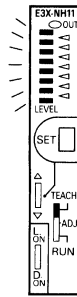

3. Set the mode selector to RUN. Be sure that only the bottom threshold indicator is lit.

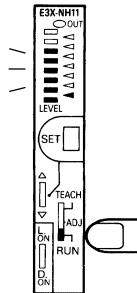

Two-point Teach Mode

1. Set the mode selector to TEACH.
Place the target object in the sensing area and press the SET button once. Be sure that all the threshold indicators (red) are lit. The built-in buzzer will beep once when the threshold indicator is lit.

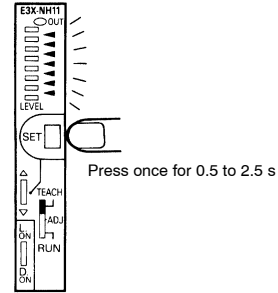

Through-beam Model

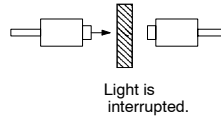

Diffuse Model

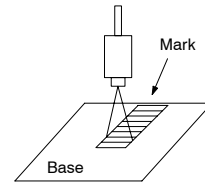

Diffuse Model

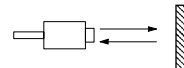

2. Remove the object and press the SET button.
If teaching is OK:
All the incident level indicators (green) will be lit. The built-in buzzer will beep once.

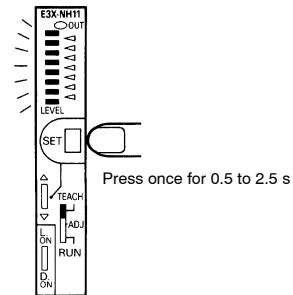

If teaching is not stable:

The threshold indicator (red) will flash. The built-in buzzer will beep 3 times.

Change the position of the object and the sensing distance that has been set and repeat the process.

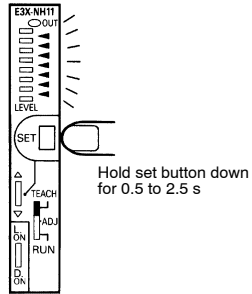

One-point Teach Mode

1. Set the mode selector to TEACH.

Press the SET button once without a target object in the sensing area. Be sure that all the threshold indicators (red) are lit. The built-in buzzer will beep once when the threshold indicators are lit.

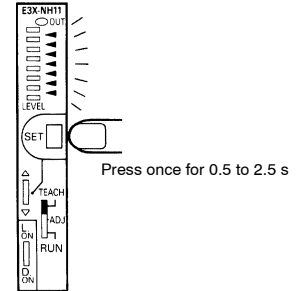

Through-beam Model

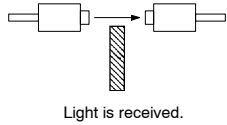

Diffuse Model

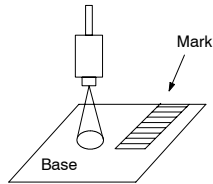

Diffuse Model

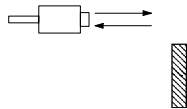

2. Set the mode selector to RUN. The threshold is set automatically.

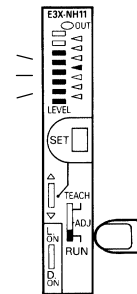

3. Set the mode selector to RUN. Be sure that the middle threshold indicator is lit. The threshold will be set to a 50% value.

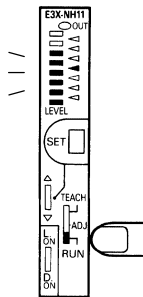

3. The Sensor will automatically compensate for environmental changes.

SENSITIVITY ADJUSTMENT (TUNING)

Manual-tuning (Fine Sensitivity Adjustment)

Note: The auto-tuning function will be disabled if manual-tuning is utilized.

1. After setting the sensitivity of the E3X-NH, select the adjustment direction with the UP/DOWN selector in the ADJ mode.

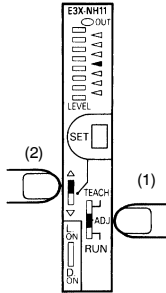

2. Press the SET button in ADJ mode. Be sure that the threshold-level changes whenever the SET button is pressed. If two threshold indicators are lit, the threshold will automatically be set to a middle value equal to the target's sensed value.

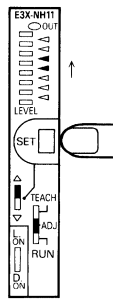

3. Set the mode selector to RUN.

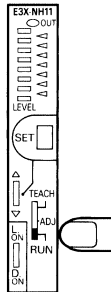

Auto-tuning (Automatic Sensitivity Compensation)

1. Set the mode selector to TEACH.
Press the SET button once without a target object in the sensing area. Be sure that all the threshold indicators (red) are lit. The built-in buzzer will beep once when the threshold indicators are lit.

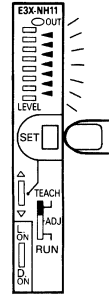

2. Set the mode selector to ADJ and press the SET button for three seconds minimum. Be sure that the threshold indicator (red) flashes. The built-in buzzer will beep continuously when cycle is complete.

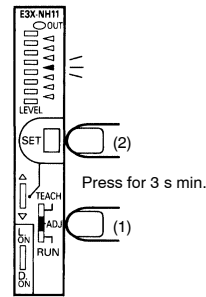

3. Set the mode selector to RUN. The threshold indicator (red) will continue to flash while the the auto-tuning function is enabled.

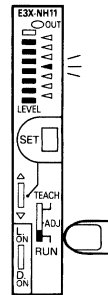

■ SENSITIVITY SETTING—THRESHOLD SETTING AND INDICATORS

Threshold indicators													
Level	1	2	3	4	5	6	7	8	9	10	11	12	13

Maximum Sensitivity Setting

- Use Through-beam Fibers for detection of opaque objects.
- Use the Diffuse Fibers for detection of objects with fixed background.

The threshold should be set to a level slightly higher than the Zero point when detecting objects that completely interrupt light.

Diffuse Sensor

The number of incident level indicators that are lit will depend on the location of the object. The bottom indicator of the threshold indicators will always be lit.

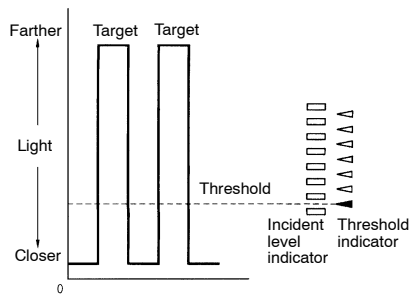

2-Point Teach Mode

- Ideal for the detection of object surface irregularities or minute objects.
- Ideal for the detection of objects against a background that reflects light irregularly.

Diffuse Sensor

1. Press the SET button *with* the target in the sensing area. Then press the SET button *without* target in the sensing area, as illustrated at the right.

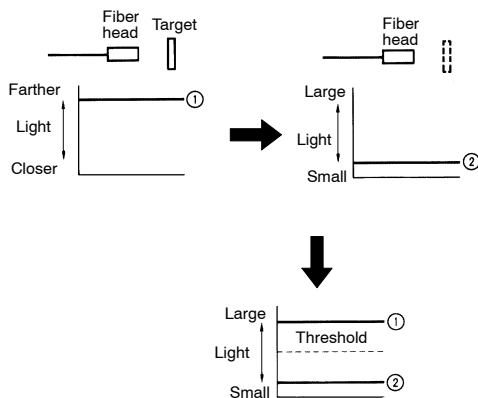

2. Set the threshold to the middle value between the values obtained with and without the target.

RUN/ADJ Mode

The number of the incident level indicators lit depends on the position of the target. When using the manual-tuning function, it is possible to adjust the threshold in six levels. The default threshold is set to 7.

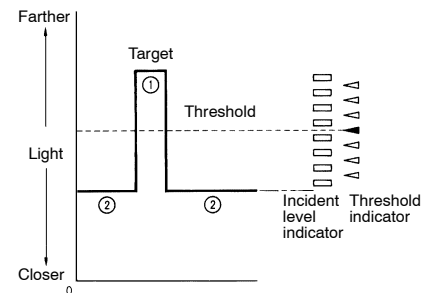

One-point Teach Mode

- Ideal if it is impossible to perform teaching with the target fixed in the sensing area.
- Ideal for high-precision positioning.
- Ideal for detection of bright or dark objects.

Diffuse (Light-ON) Fiber Unit

1. Press the SET button without the target in the sensing area.
Set the threshold to the value that is $\pm 6\%$ of the incident level.

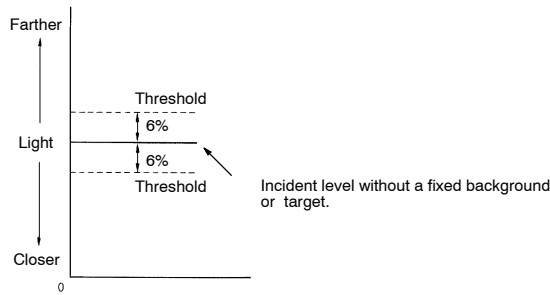

Note: If the target is not present at the time of teaching, the threshold cannot be set to the position corresponding to -6% of the incident level. The sensitivity will then be set to maximum automatically when in RUN mode.

2. Detecting the first object in RUN/ADJ mode.

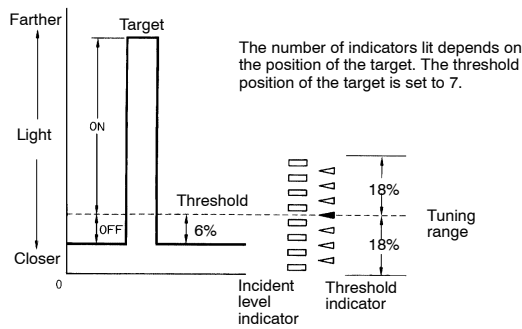

Through-beam (Dark-ON) Fiber Unit

1. Press the SET button without target in the sensing area.
Set the threshold to the value that is $\pm 6\%$ of the incident level.

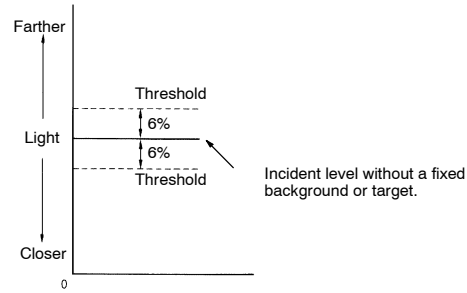

2. Detecting the first object in RUN/ADJ mode.

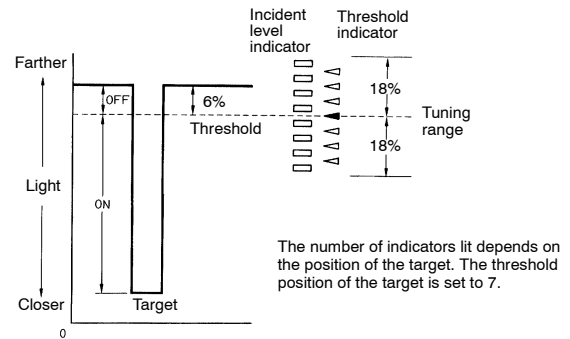

The number of indicators lit depends on the position of the target. The threshold position of the target is set to 7.

■ THRESHOLD LEVEL AND INDICATOR LEVELS

Setting the Initial Threshold

- To set the initial threshold, perform One-point teaching by pressing the SET button for a minimum of 3 seconds.
- As a result of target movement during operation, the middle value between the highest and lowest point on the incident scale will be obtained. The E3X-NH will perform an auto-tuning function within a range of $\pm 18\%$ of this value.

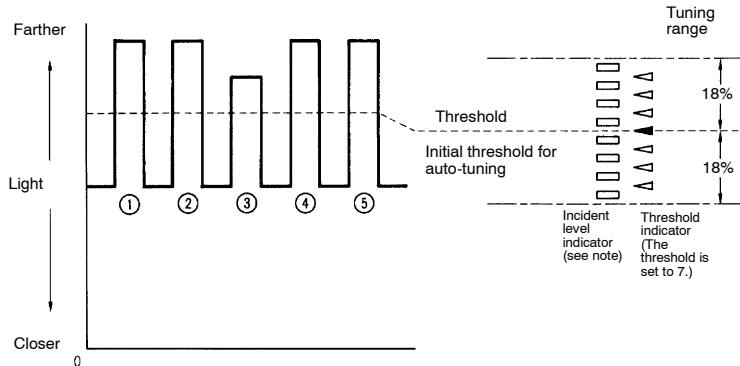

Note: The number of Incident-level indicators lit depends on the presence of the target.

Threshold Compensation

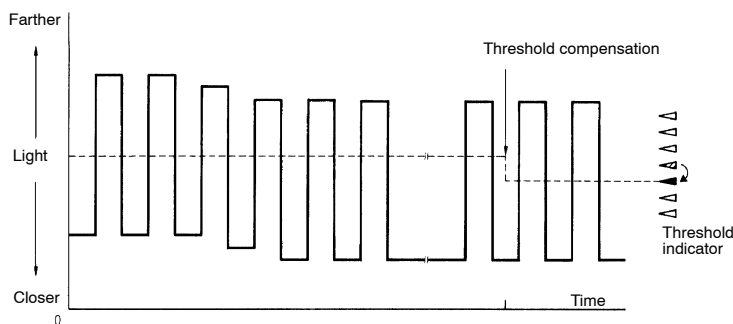

- The sensor will perform an Automatic Threshold Compensation within the preset band.
- After the threshold has been compensated, the Threshold Indicator will flash, indicating the adjusted value.
- Threshold compensation occurs at 1, 3, 6, 10, 15, 22, and 30 minutes after **turning on** the E3X-NH. After the initial 30-minute time-frame, Threshold Compensation is continually repeated, every 30-minutes.
- Alarm output will occur if the threshold compensation range is not within the tuning range. Perform sensitivity setting again if the alarm signal turns ON.

Dimensions

Unit: mm (inch)

■ AMPLIFIER

E3X-NH□1

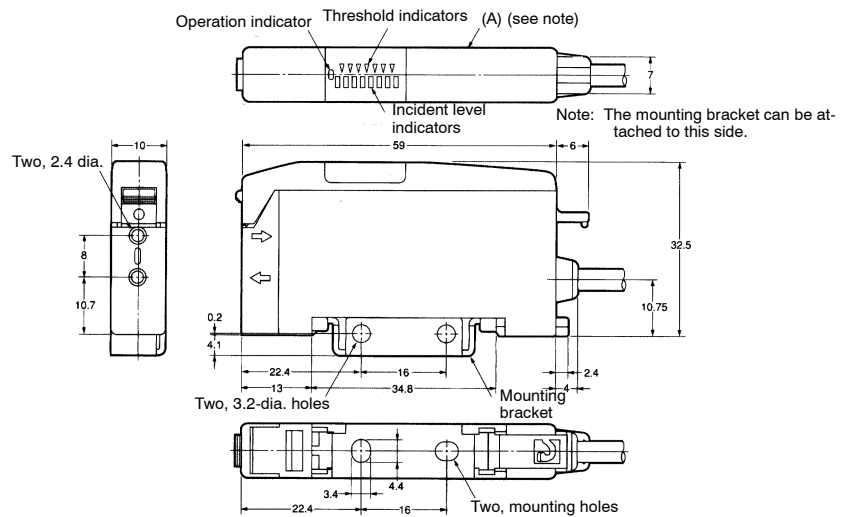
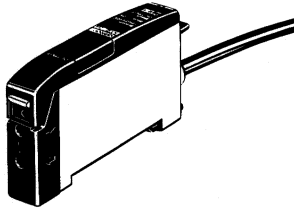

Cable: Polyvinyl chloride-covered cord
 4-mm dia. (18/0.12 dia), 4 stranded conductors
 Standard length: 2 m

Weight: Approx. 100 g

Installation

■ CUTTING FIBER

Insert a fiber into the Fiber Cutter and determine the length of the fiber to be cut.

Press down the Fiber Cutter in a single stroke to cut the fiber.

An insertion mark can be placed on the fiber to serve as a reference when inserting the fiber into the Amplifier. Use the following procedure.

Confirm through the Cutter hole that the fiber is inserted beyond the insertion mark hole so that the insertion mark is properly indicated, and then press firmly down on the Cutter.

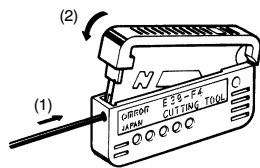

Insert the fiber into the Amplifier up to the insertion mark. Proper fiber performance will not be achieved unless the fiber is inserted all the way to the insertion mark. (This method is applicable to standard, 2.2-mm-diameter fibers only.)

■ FIBER CONNECTION OR DISCONNECTION PROCEDURES

The E3X-NH Amplifier has a lock button. Follow these steps to connect or disconnect the fibers to (or from) the E3X-NH Amplifier:

Note: The fiber must be locked or released in a temperature range of -10°C to 40°C (14°F to 104°F).

Connection

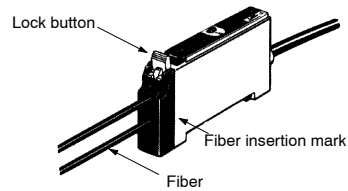

1. After cutting the fibers (using the E39-F4 Fiber Cutter), place an insertion mark on the fiber so that it can be correctly inserted into the Amplifier.
2. Insert the fiber into the Amplifier up to this insertion mark.
3. Press the lock button to lock the fiber in that position.

Disconnection

1. Before pulling out the fiber, you MUST first press the lock button to release (unlock) the fiber, or you may damage the fiber.
2. Then, pull the fiber from the amplifier.

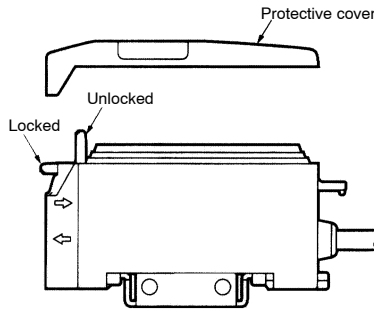

Procedure for Inserting the Fiber

If the portion from the tip to the insertion mark of the fiber is not inserted into the Amplifier Unit, the sensing distance will be reduced.

2.2-mm-dia. Fiber

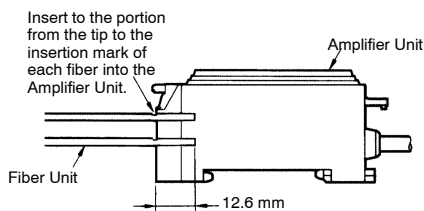

Thin Fiber with the E39-F9 Attachment

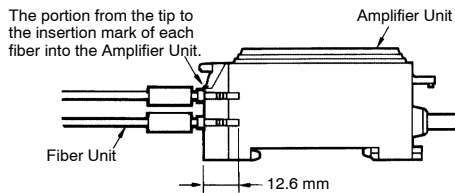

Fiber with Fixed Length

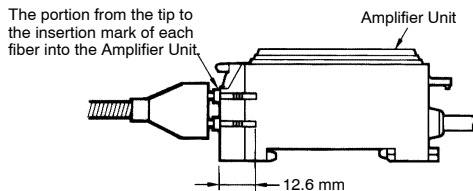

BENDING RADIUS

E39-F11 Sleeve Bender

The bending radius of the stainless tube should be as large as possible. The smaller the bending radius becomes, the shorter the sensing distance will be.

Insert the tip of the stainless tube to the Sleeve Bender and bend the stainless tube slowly along the curve of the Sleeve Bender (refer to the figure).

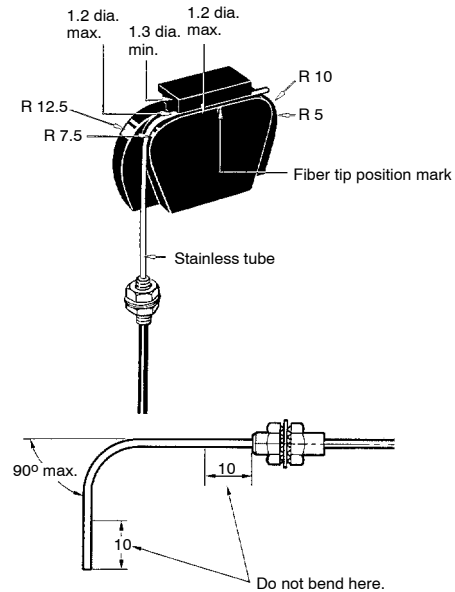

REFLECTOR

Observe the Following Precautions when Using the Reflector (E39-R3)

Use detergent, etc., to remove any dust or oil from the surfaces where tape is applied. Adhesive tape will not be attached properly if oil or dust remains on the surface.

The E39-R3 cannot be used in places where it is exposed to oil or chemicals.

■ ATTACHMENT UNITS

Applications

E39-F10 Fiber Connector

Use the following procedure (refer to the figure) to connect fibers via the Fiber Connector.

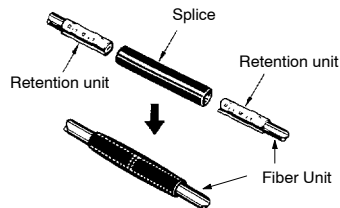

Each Fiber Unit should be as close as possible before they are connected.

Sensing distance will be reduced by approximately 25% when fibers are connected.

Only fibers with a 2.2-mm dia. can be connected. (Refer to page NO TAG for applicable Fiber Units.)

Protective Spiral Tube

Insert a fiber to the Protective Spiral Tube from the head connector side (threaded) of the tube.

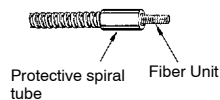

Push the fiber into the Protective Spiral Tube. The tube should be straight so that the fiber is not twisted when inserted. Then turn the end cap of the spiral tube.

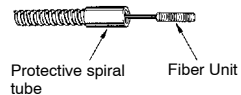

Secure the Protective Spiral Tube on a suitable place with the attached nut.

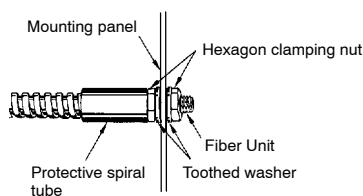

Use the attached saddle to secure the end cap of the Protective Spiral Tube. To secure the Protective Spiral Tube at a position other than the end cap, apply tape to the tube so that the portion becomes thicker in diameter.

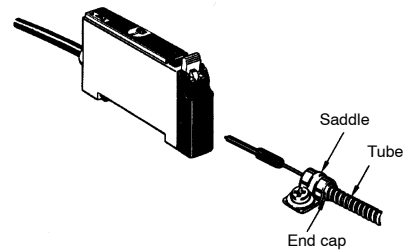

■ AMPLIFIER UNITS

Mounting

1. Mount the *front part* (see #1) to the mounting bracket (attachment) or on a DIN rail.
2. Press the *back part* (see #2) onto the mounting bracket or onto the DIN rail.

Note: *DO NOT* mount the back part on the mounting bracket or the DIN rail first and then mount the front part on the mounting bracket on the DIN rail. This could decrease the mounting strength of the Amplifier Unit.

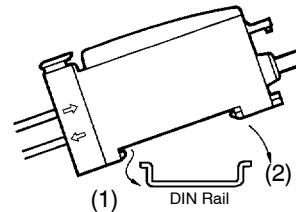

Removal

You can remove the Amplifier in one easy step:

1. Press the Amplifier Unit in direction (A) and lift the fiber insertion part in direction (B) as shown here

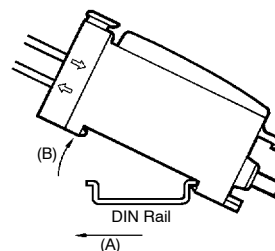

When Side-Mounting

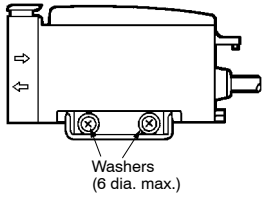

When side-mounting:
Attach the mounting bracket on the Amplifier first, and secure the amplifier with M3 screws and washers. The diameter of the washers should be a maximum of 6 mm.

Insert the fiber into the Amplifier up to the insertion mark. Proper fiber performance will not be achieved unless the fiber is inserted all the way to the insertion mark. (This method is applicable to standard, 2.2-mm-diameter fibers only.)

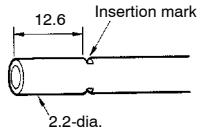

The cutting holes cannot be used twice. If the same hole is used twice, the cutting face of the fiber will be rough and the sensing distance will be reduced. Always use an unused hole.

Use either one of the two holes on the right (refer to the following figure) to cut a thin fiber as follows:

1. An attachment is temporarily fitted to a thin fiber before shipment.

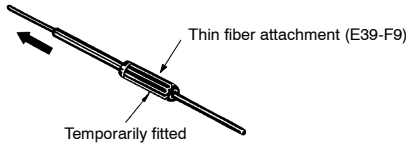

2. Secure the attachment after adjusting the position of it in the direction indicated by the arrow.



3. Insert the fiber into the E39-F4 to cut.

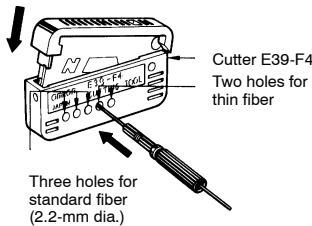

4. Finished state (proper cutting state)



Note: Insert the fiber in the direction indicated by the arrow.

Connection

Do not pull or press the Fiber Units. The Fiber Units have a withstand force of 9.8 N (1 kgf) or 29.4 N (3 kgf) (pay utmost attention because the fibers are thin).

Do not bend the Fiber Units beyond the permissible bending radius.

Do not bend the edge of the Fiber Units (excluding the E32-T□R and E32-D□R).

Correct

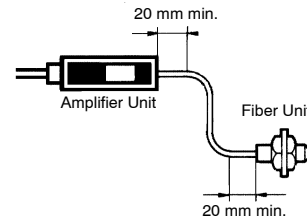

Incorrect

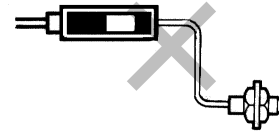

Do not apply excess force on the Fiber Units.

Correct

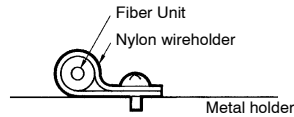

Incorrect



The Fiber Head could be break by excessive vibration. To prevent this, the following is effective:

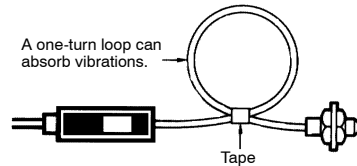

Turning the Power ON

When the power is turned ON, the operation indicator will be ON momentarily. Note that this will not have an effect on performance since no control output will be generated.

When the power is turned ON, the operation indicator will be ON momentarily. Note that this will not have an effect on performance since no control output will be generated.

Perform two-point teaching if two to three Fiber Units are closely mounted together, at which time supply power only to the Unit in teaching operation in turn or block the emitters of the Fiber Units not in teaching operation.

Precautions



WARNING

The E3X-NH is not a safety component for ensuring the safety of people as defined in EC Directive 91/368/EEC, or as covered by separate European standards or by any other regulations or standards.

■ AVOID DAMAGE TO THE E3X-NH SENSOR

- Do not impose any voltage exceeding the rated voltage on the E3X-NH.
- Do not impose 100 VAC or more on models that operate with DC.
- When supplying power to the E3X-NH, make sure that the polarity of the power is correct.
- Do not short-circuit the load connected to the E3X-NH.
- The load must be connected to the E3X-NH in operation.

■ REFLECTOR

Precautions for Using the E39-R3 Reflector

Use detergent, etc., to remove any dust or oil from the surfaces where tape is applied. Adhesive tape will not be attached properly if oil or dust remains on the surface.

The E39-R3 cannot be used in places where it is exposed to oil or chemicals.

■ MUTUAL INTERFERENCE PROTECTION

Perform two-point teaching if two to three Fiber Units are closely mounted together. The mutual interference feature will guard against false triggering.

■ EEPROM WRITING ERROR

Write errors may result at the time of teaching due to power failure or static noise. If any of these occur, re-teach the amplifier.

■ SENSING A MINUTE OBJECT

This data sheet shows typical examples for detecting minute objects. These typical examples are for reference use only, because these example operations were tested on Units sampled at random from a lot and the values described are average values. Do not assume that all Units ensure such operations.

■ WHEN THE POWER IS OFF

The moment power is turned off, the E3X-NH may output a pulse signal which could affect the operation of the devices connected to it. This will occur more often if power is supplied to the E3X-NH from an external power supply, thus affecting the connected timer or counter. We recommend using a separate power supply to avoid a false signal.

For extending the cable, use wire with 0.3 mm² min. The total length of the cable should be a maximum of 100 m.

■ POWER SUPPLY

If a standard switching regulator is used as a power supply, the frame ground (FG) terminal and the ground (G) terminal must be grounded, or the Amplifier can malfunction due to the switching noise of the power supply.

The supplied voltage must be within the rated voltage range. Unregulated full- or half-wave rectifiers must not be used as power supplies.

■ WIRING

Never wire the Amplifier within the same conduit with power lines. Doing so will cause induction between the lines, possibly resulting in faulty operation or damage. Always wire the Amplifier in a separate, dedicated conduit.

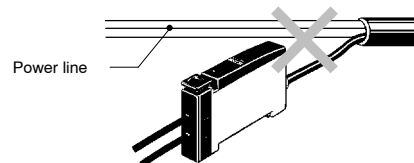

NOTE: DIMENSIONS SHOWN ARE IN MILLIMETERS. To convert millimeters to inches divide by 25.4.

OMRON®

OMRON ELECTRONICS LLC
One East Commerce Drive
Schaumburg, IL 60173
1-800-55-OMRON

OMRON ON-LINE

Global - <http://www.omron.com>
USA - <http://www.omron.com/oei>
Canada - <http://www.omron.com/oci>

OMRON CANADA, INC.

885 Milner Avenue
Scarborough, Ontario M1B 5V8
416-286-6465