

AC Servomotors and SMARTSTEP 2-series Servo Drives with Pulse String Inputs

# R88M-G/R7D-BP

## Advanced Functionality in a Super Compact Design.

- Compact AC Servo Drives

The footprint of the compact AC Servo Drives is only 48% that of the SMARTSTEP A Series, and the volume is only 39%. The AC Servo Drives of the SMARTSTEP 2 Series are also equipped with new functions and higher performance for more accurate positioning.

- Vibration Suppressed during Acceleration/Deceleration of Low-rigidity Mechanisms

Damping control suppresses vibration when using the SMARTSTEP 2 for low-rigidity mechanisms or devices in which the end vibrates.

- Resonance Control for High-speed Positioning

Realtime autotuning estimates the load inertia of the machine in realtime and automatically and constantly sets the optimal gain. The adaptive filter automatically suppresses vibration caused by resonance.

- Compatible with 90° Phase Difference Input Command Pulses

In addition to conventional CW/CCW inputs (2 pulses) and SIGN/PULS inputs (1 pulse), the SMARTSTEP 2 supports 90° phase difference inputs. This makes it possible to input encoder output signals directly into the Servo Drive for simplified synchronization control.

## System Configuration

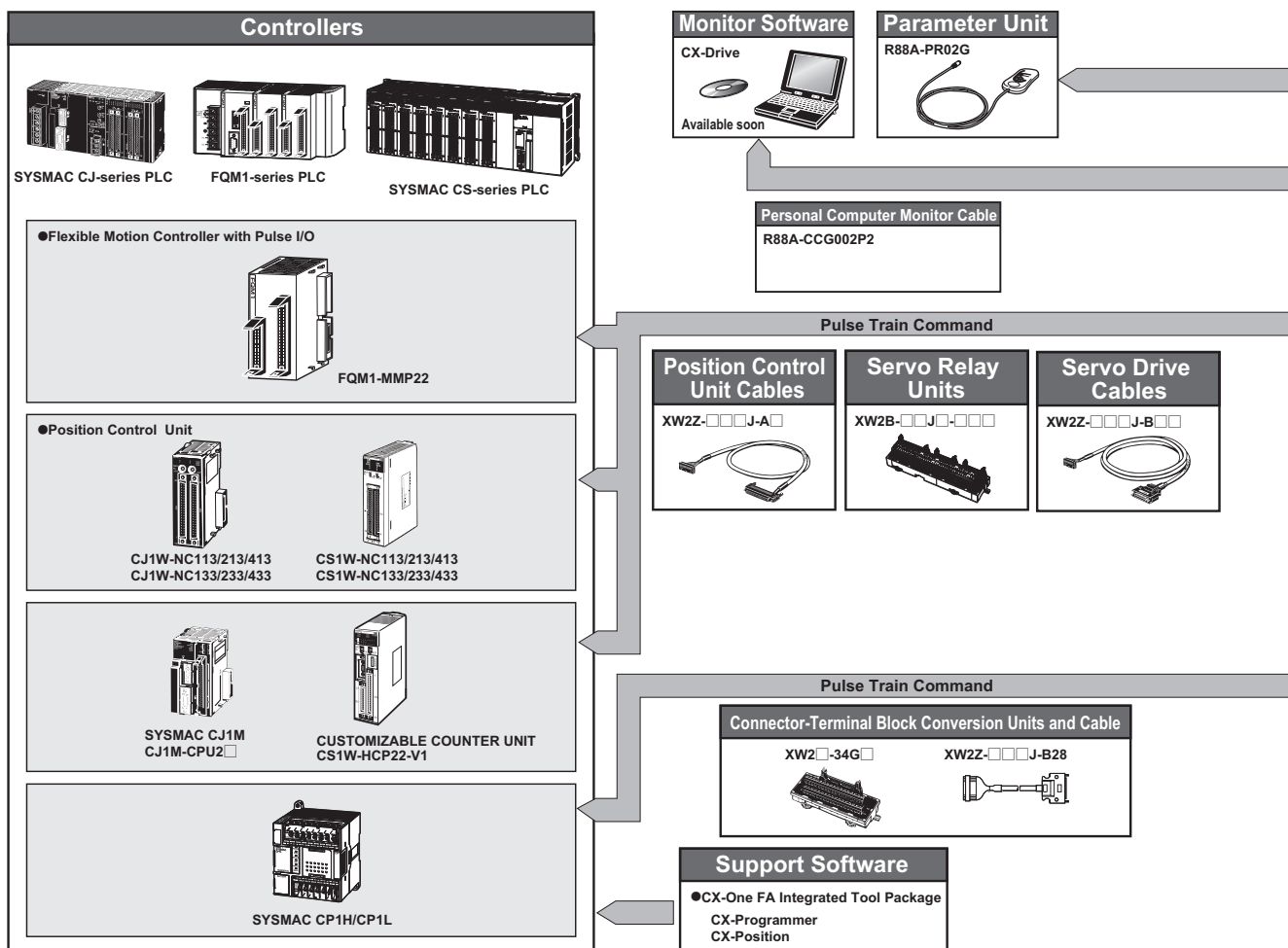

- **A Wide Range of Pulse Settings**  
A wide range of pulse settings, such as the command pulse factor, electronic gear, and encoder dividing rate, enable optimal pulse settings for your device or system.
- **Simplified Speed Control with Internal Speed Settings**  
Four internal speed settings allow the speed to be easily switched by using external signals.
- **Encoder Output Dividing**  
The number of motor encoder pulses output by the Servo Drive can be freely set between 1 and 2,500 pulses per rotation. A parameter can also be set to change the phase.

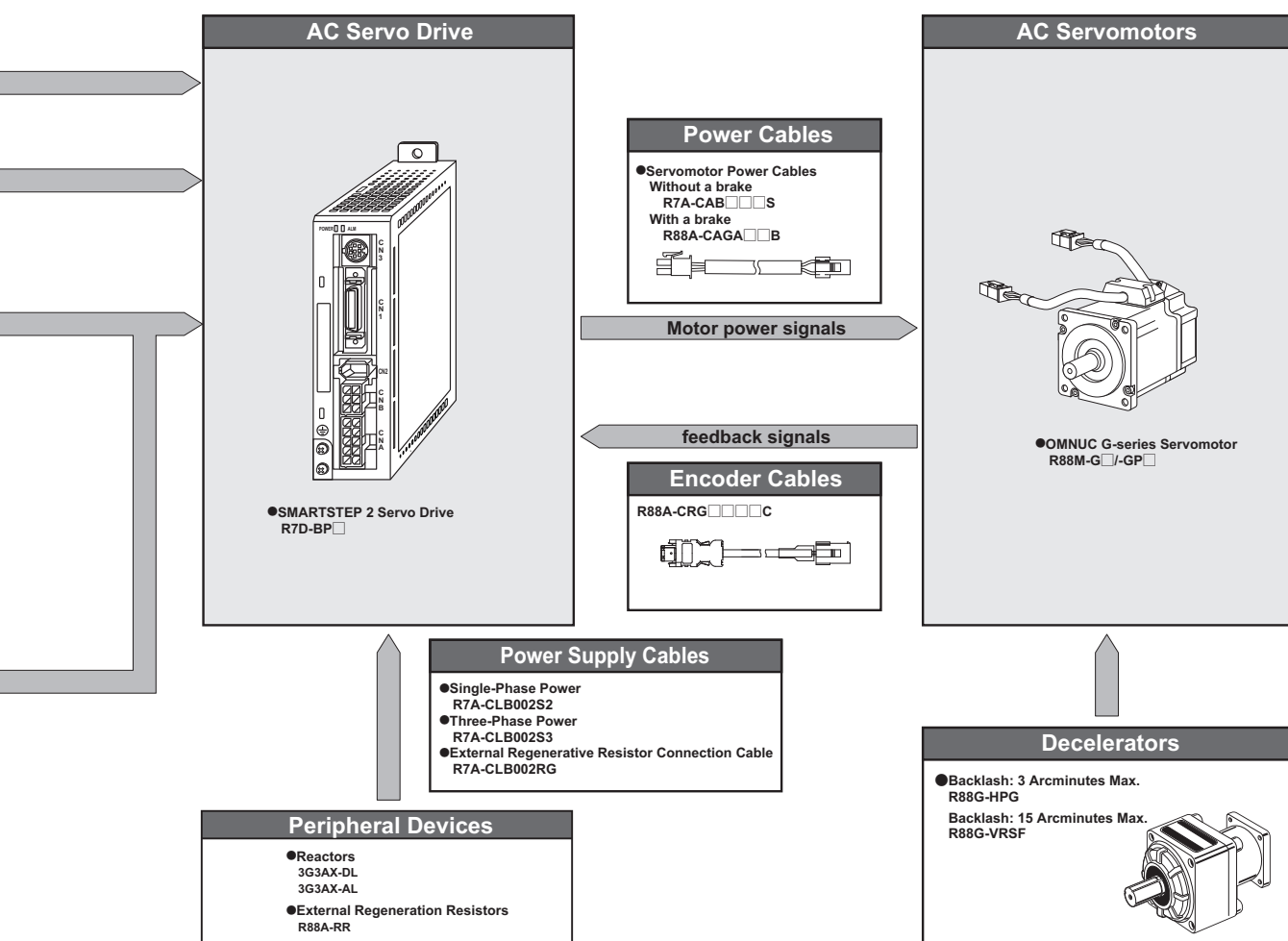

## Interpreting Model Numbers

### ● Servo Drive Model Numbers

The model number provides information such as the Servo Drive type, the applicable Servomotor capacity, and the power supply voltage.

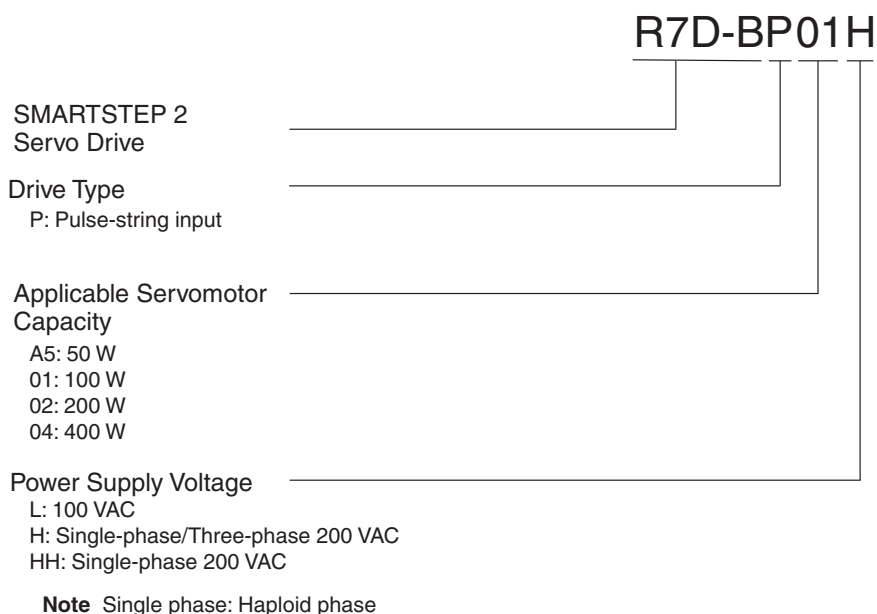

### ● Servomotor Model Numbers

The model number provides information such as the Servomotor type, Servomotor capacity, rated speed, and options.

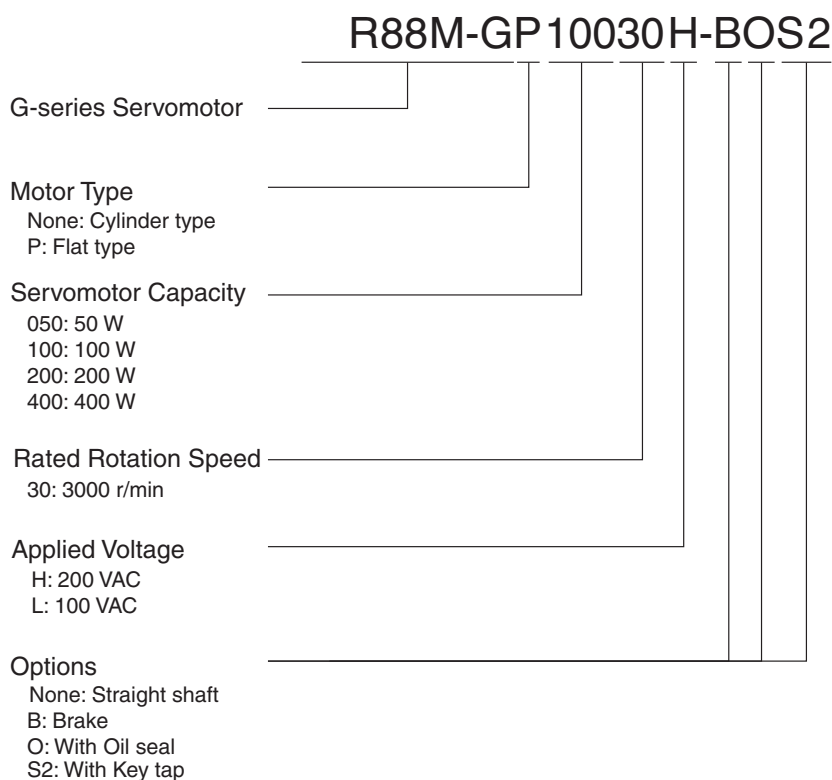

## Ordering Information

### ● Servo Drives

Specifications		Model
Single-phase 100 VAC	50 W	R7D-BPA5L
	100 W	R7D-BP01L
	200 W	R7D-BP02L
Single-phase/three-phase 200 VAC	50 W	R7D-BP01H
	100 W	
	400 W	R7D-BP04H
Single-phase 200 VAC	200 W	R7D-BP02HH
Three-phase 200 VAC	200 W	R7D-BP02H

### ● Servomotors

#### **INC** 3,000-r/min Cylindrical Servomotors

Specifications			Model	
			Straight shaft	Straight shaft with key and tap
Without brake	100 V	50 W	R88M-G05030H	R88M-G05030H-S2
		100 W	R88M-G10030L	R88M-G10030L-S2
		200 W	R88M-G20030L	R88M-G20030L-S2
	200 V	50 W	R88M-G05030H	R88M-G05030H-S2
		100 W	R88M-G10030H	R88M-G10030H-S2
		200 W	R88M-G20030H	R88M-G20030H-S2
With brake	100 V	50 W	R88M-G05030H-B	R88M-G05030H-BS2
		100 W	R88M-G10030L-B	R88M-G10030L-BS2
		200 W	R88M-G20030L-B	R88M-G20030L-BS2
	200 V	50 W	R88M-G05030H-B	R88M-G05030H-BS2
		100 W	R88M-G10030H-B	R88M-G10030H-BS2
		200 W	R88M-G20030H-B	R88M-G20030H-BS2
		400 W	R88M-G40030H-B	R88M-G40030H-BS2

Note: Models with oil seals are also available.

#### **INC** 3,000-r/min Flat Servomotors

Specifications			Model	
			Straight shaft	Straight shaft with key and tap
Without brake	100 V	100W	R88M-GP10030L	R88M-GP10030L-S2
		200W	R88M-GP20030L	R88M-GP20030L-S2
	200 V	100W	R88M-GP10030H	R88M-GP10030H-S2
		200W	R88M-GP20030H	R88M-GP20030H-S2
		400W	R88M-GP40030H	R88M-GP40030H-S2
With brake	100 V	100W	R88M-GP10030L-B	R88M-GP10030L-BS2
		200W	R88M-GP20030L-B	R88M-GP20030L-BS2
	200 V	100W	R88M-GP10030H-B	R88M-GP10030H-BS2
		200W	R88M-GP20030H-B	R88M-GP20030H-BS2
		400W	R88M-GP40030H-B	R88M-GP40030H-BS2

Note: Models with oil seals are also available.

● Decelerators

**Backlash: 3 Arcminutes Max.**

**Decelerators for Cylindrical Servomotors**

Specifications		Model
Motor capacity	Gear ratio	
50 W	1/5	R88G-HPG11A05100B
	1/9	R88G-HPG11A09050B
	1/21	R88G-HPG14A21100B
	1/33	R88G-HPG14A33050B
	1/45	R88G-HPG14A45050B
100 W	1/5	R88G-HPG11A05100B
	1/11	R88G-HPG14A11100B
	1/21	R88G-HPG14A21100B
	1/33	R88G-HPG20A33100B
	1/45	R88G-HPG20A45100B
200 W	1/5	R88G-HPG14A05200B
	1/11	R88G-HPG14A11200B
	1/21	R88G-HPG20A21200B
	1/33	R88G-HPG20A33200B
400 W	1/45	R88G-HPG20A45200B
	1/5	R88G-HPG14A05400B
	1/11	R88G-HPG20A11400B
	1/21	R88G-HPG20A21400B
400 W	1/33	R88G-HPG32A33400B
	1/45	R88G-HPG32A45400B

**Note: 1.** The standard models have a straight shaft.

**Note: 2.** To order a Servomotor with a straight shaft with key, add "J" to the end of the model number, in the place indicated by the box.

Example: R88G-HPG11A05100BJ

**Backlash: 3 Arcminutes Max.**

**Decelerator for Flat Servomotors**

Specifications		Model
Motor capacity	Gear ratio	
100 W	1/5	R88G-HPG11A05100PB
	1/11	R88G-HPG14A11100PB
	1/21	R88G-HPG14A21100PB
	1/33	R88G-HPG20A33100PB
	1/45	R88G-HPG20A45100PB
200 W	1/5	R88G-HPG14A05200PB
	1/11	R88G-HPG20A11200PB
	1/21	R88G-HPG20A21200PB
	1/33	R88G-HPG20A33200PB
	1/45	R88G-HPG20A45200PB
400 W	1/5	R88G-HPG20A05400PB
	1/11	R88G-HPG20A11400PB
	1/21	R88G-HPG20A21400PB
	1/33	R88G-HPG32A33400PB
	1/45	R88G-HPG32A45400PB

**Note: 1.** The standard models have a straight shaft.

**Note: 2.** To order a Servomotor with a straight shaft with key, add "J" to the end of the model number, in the place indicated by the box.

Example: R88G-HPG11A05100BJ

**Backlash: 15 Arcminutes Max.**

**Decelerators for Cylindrical Servomotors**

Specifications		Model
Motor capacity	Gear ratio	
50 W	1/5	R88G-VRSF05B100CJ
	1/9	R88G-VRSF09B100CJ
	1/15	R88G-VRSF15B100CJ
	1/25	R88G-VRSF25B100CJ
	1/45	R88G-VRSF45B100CJ
100 W	1/5	R88G-VRSF05B100CJ
	1/9	R88G-VRSF09B100CJ
	1/15	R88G-VRSF15B100CJ
	1/25	R88G-VRSF25B100CJ
200 W	1/5	R88G-VRSF05B200CJ
	1/9	R88G-VRSF09C200CJ
	1/15	R88G-VRSF15C200CJ
400 W	1/25	R88G-VRSF25C200CJ
	1/5	R88G-VRSF05C400CJ
	1/9	R88G-VRSF09C400CJ
	1/15	R88G-VRSF15C400CJ
400 W	1/25	R88G-VRSF25C400CJ

**Note: 1.** The standard models have a straight shaft with a key.

**Note: 2.** The backlash is the value when a load of  $\pm 5\%$  of the allowable output torque is applied to the output shaft.

**Backlash: 15 Arcminutes Max.**

**Decelerators for Flat Servomotors**

Specifications		Model
Motor capacity	Gear ratio	
100 W	1/5	R88G-VRSF05B100PCJ
	1/9	R88G-VRSF09B100PCJ
	1/15	R88G-VRSF15B100PCJ
	1/25	R88G-VRSF25B100PCJ
200 W	1/5	R88G-VRSF05B200PCJ
	1/9	R88G-VRSF09C200PCJ
	1/15	R88G-VRSF15C200PCJ
400 W	1/25	R88G-VRSF25C200PCJ
	1/5	R88G-VRSF05C400PCJ
	1/9	R88G-VRSF09C400PCJ
	1/15	R88G-VRSF15C400PCJ
400 W	1/25	R88G-VRSF25C400PCJ

**Note: 1.** The standard models have a straight shaft with a key.

**Note: 2.** The backlash is the value when a load of  $\pm 5\%$  of the allowable output torque is applied to the output shaft.

● Accessories and Cables

**Control Cables (for CN1)**

Specifications		Model
Connector-Terminal Block Cables	1 m	XW2Z-100J-B28
	2 m	XW2Z-200J-B28
General-purpose Control Cables	1 m	R7A-CPB001S
	2 m	R7A-CPB002S

**Encoder Cables (for CN2) \*1**

Specifications		Model
Standard Cables (connectors attached)	3 m	R88A-CRGB003C
	5 m	R88A-CRGB005C
	10 m	R88A-CRGB010C
	15 m	R88A-CRGB015C
	20 m	R88A-CRGB020C

**Servomotor Power Cables (for CNB) \*1**

Specifications		Model
Standard Cables (connectors attached)	3 m	R7A-CAB003S
	5 m	R7A-CAB005S
	10 m	R7A-CAB010S
	15 m	R7A-CAB015S
	20 m	R7A-CAB020S

**Brake Cables**

Specifications		Model
Standard Cables	3 m	R88A-CAGA003B
	5 m	R88A-CAGA005B
	10 m	R88A-CAGA010B
	15 m	R88A-CAGA015B
	20 m	R88A-CAGA020B

**Personal Computer Monitor Cable**

Specifications		Model
Personal Computer Monitor Cable	2 m	R88A-CCG002P2

**Power Supply Cables**

Specifications		Model
Power Supply Input Cable for Single-Phase Power (connectors attached)	2 m	R7A-CLB002S2
Power Supply Input Cable for Three-Phase Power (connectors attached)	2 m	R7A-CLB002S3
External Regenerative Resistor Connection Cable	2 m	R7A-CLB002RG

**Connectors**

Specifications	Model
Main Circuit Connector (CNA)	R7A-CNB01P
Servomotor Connector (CNB)	R7A-CNB01A
Control Input Connector (CN1)	R88A-CNW01C
Encoder Input Connector (CN2)	R88A-CNW01R
Servomotor Connector for Encoder Cable	R88A-CNG02R
Servomotor Connector for Servomotor Power Cable	R88A-CNG01A

**Connector-Terminal Block Conversion Units**

Specifications	Model
With M3 screws	XW2B-34G4
With M3.5 screws	XW2B-34G5
With M3 screws	XW2D-34G6

**External Regeneration Resistors**

Specifications	Model
220 W, 47 Ω	R88A-RR22047S
80 W, 100 Ω	R88A-RR080100S
80 W, 50 Ω	R88A-RR08050S

**Reactors**

Specifications	Applicable Servo Drive	Model
Single-phase 100 V	R7D-BPA5L	3G3AX-DL2002
	R7D-BP01L	3G3AX-DL2004
	R7D-BP02L	3G3AX-DL2007
Single-phase 200 V	R7D-BP01H	3G3AX-DL2004
	R7D-BP02HH	3G3AX-DL2004
	R7D-BP04H	3G3AX-DL2007
	R7D-BP01H	3G3AX-AL2025
Three-phase 200 V	R7D-BP02H	3G3AX-AL2025
	R7D-BP04H	3G3AX-AL2025

**DIN Rail Mounting Unit**

Specifications	Model
DIN Rail Mounting Unit	R7A-DIN01B

**Parameter Unit**

Specifications	Model
Parameter Unit	R88A-PR02G

\*1. Robot Cable are also available soon.

### Servo Relay Units (for CN1)

Specifications	Model
For CJ1W-NC133/-NC113 For CS1W-NC133/-NC113 For C200HW-NC113	XW2B-20J6-1B
For CJ1W-NC233/-NC433/-NC213/-NC413 For CS1W-NC233/-NC433/-NC213/-NC413 For C200HW-NC213/-NC413	XW2B-40J6-2B
For CJ1M-CPU21 For CJ1M-CPU22 For CJ1M-CPU23	XW2B-20J6-8A XW2B-40J6-9A (for 2 axis)
For FQM1-MMP22	XW2B-80J7-12A
For CQM1H-PLB21	XW2B-20J6-3B

### Servo Relay Unit Cables (for Servo Drives)

Specifications	Model
For Position Control Unit/CQM1 (XW2B-□J6-□B)	1 m XW2Z-100J-B29
	2 m XW2Z-200J-B29
For CJ1M (XW2B-20J6-8A/XW2B-40J6-9A)	1 m XW2Z-100J-B32
	2 m XW2Z-200J-B32
For FQM1-MMP22 (XW2B-80J7-12A)	1 m XW2Z-100J-B30
	2 m XW2Z-200J-B30

### Servo Relay Unit Cables (for Position Control Units)

Specifications	Model	
For CJ1W-NC133	0.5 m XW2Z-050J-A18	
	1 m XW2Z-100J-A18	
For CJ1W-NC233/-NC433	0.5 m XW2Z-050J-A19	
	1 m XW2Z-100J-A19	
For CS1W-NC133	0.5 m XW2Z-050J-A10	
	1 m XW2Z-100J-A10	
For CS1W-NC233/-NC433	0.5 m XW2Z-050J-A11	
	1 m XW2Z-100J-A11	
For CJ1W-NC113	0.5 m XW2Z-050J-A14	
	1 m XW2Z-100J-A14	
For CJ1W-NC213/-NC413	0.5 m XW2Z-050J-A15	
	1 m XW2Z-100J-A15	
For CS1W-NC113 For C200HW-NC113	0.5 m XW2Z-050J-A6	
	1 m XW2Z-100J-A6	
For CS1W-NC213/-NC413 For C200HW-NC213/-NC413	0.5 m XW2Z-050J-A7	
	1 m XW2Z-100J-A7	
For CJ1M-CPU21 For CJ1M-CPU22 For CJ1M-CPU23	0.5 m XW2Z-050J-A33	
	1 m XW2Z-100J-A33	
For FQM1-MMP22	General-purpose I/O Cables	0.5 m XW2Z-050J-A28
		1 m XW2Z-100J-A28
		2 m XW2Z-200J-A28
	Special I/O Cables	0.5 m XW2Z-050J-A30
		1 m XW2Z-100J-A30
		2 m XW2Z-200J-A30
For CQM1H-PLB21	0.5 m XW2Z-050J-A3	
	1 m XW2Z-100J-A3	

## Servo Drive-Servomotor Combinations

Only the Servomotor and Servo Drive combinations listed here can be used. Do not use other combinations.

### ● Cylindrical Servomotor

#### Servomotors Combinations

Voltage	Servo Drive	Servomotor		
	Pulse-string input	Rated output	Without brake	With brake
Single-phase 100VAC	R7D-BPA5L	50 W	R88M-G05030H	R88M-G05030H-B
	R7D-BP01L	100 W	R88M-G10030L	R88M-G10030L-B
	R7D-BP02L	200 W	R88M-G20030L	R88M-G20030L-B
Single-phase 200 VAC	R7D-BP01H	50 W	R88M-G05030H	R88M-G05030H-B
		100 W	R88M-G10030H	R88M-G10030H-B
	R7D-BP02HH	200 W	R88M-G20030H	R88M-G20030H-B
	R7D-BP04H	400 W	R88M-G40030H	R88M-G40030H-B
Three-phase 200 VAC	R7D-BP01H	50 W	R88M-G05030H	R88M-G05030H-B
		100 W	R88M-G10030H	R88M-G10030H-B
	R7D-BP02H	200 W	R88M-G20030H	R88M-G20030H-B
	R7D-BP04H	400 W	R88M-G40030H	R88M-G40030H-B

### ● Flat Servomotor

#### Servomotors Combinations

Voltage	Servo Drive	Servomotor		
	Pulse-string input	Rated output	Without brake	With brake
Single-phase 100VAC	R7D-BP01L	100 W	R88M-GP10030L	R88M-GP10030L-B
	R7D-BP02L	200 W	R88M-GP20030L	R88M-GP20030L-B
Single-phase 200 VAC	R7D-BP01H	100 W	R88M-GP10030H	R88M-GP10030H-B
	R7D-BP02HH	200 W	R88M-GP20030H	R88M-GP20030H-B
	R7D-BP04H	400 W	R88M-GP40030H	R88M-GP40030H-B
Three-phase 200 VAC	R7D-BP01H	100 W	R88M-GP10030H	R88M-GP10030H-B
	R7D-BP02H	200 W	R88M-GP20030H	R88M-GP20030H-B
	R7D-BP04H	400 W	R88M-GP40030H	R88M-GP40030H-B

## Servo Relay Units and Cables

Select the Servo Relay Unit and Cable according to the model number of the Position Control Unit being used.

Position Control Unit	Position Control Unit Cable		Servo Relay Unit	Servo Drive Cable
CJ1W-NC133	XW2Z-□□□J-A18		XW2B-20J6-1B	XW2Z-□□□J-B29
CJ1W-NC233	XW2Z-□□□J-A19		XW2B-40J6-2B	
CJ1W-NC433				
CS1W-NC133	XW2Z-□□□J-A10		XW2B-20J6-1B	
CS1W-NC233	XW2Z-□□□J-A11		XW2B-40J6-2B	
CS1W-NC433				
CJ1W-NC113				
CJ1W-NC213	XW2Z-□□□J-A15		XW2B-40J6-2B	
CJ1W-NC413				
CS1W-NC113	XW2Z-□□□J-A6		XW2B-20J6-1B	
C200HW-NC113				
CS1W-NC213	XW2Z-□□□J-A7		XW2B-40J6-2B	
CS1W-NC413				
C200HW-NC213				
C200HW-NC413				
CJ1M-CPU21	XW2Z-□□□J-A33		XW2B-20J6-8A XW2B-40J6-9A (for 2 axes)	XW2Z-□□□J-B32
CJ1M-CPU22				
CJ1M-CPU23				
FQM1-MMP22	General-purpose I/O Cable	XW2Z-□□□J-A28	XW2B-80J7-12A	XW2Z-□□□J-B30
	Special I/O Cable	XW2Z-□□□J-A30		
CQM1H-PLB21	XW2Z-□□□J-A3		XW2B-20J6-3B	XW2Z-□□□J-B29

**Note: 1.** Insert the cable length into the boxes in the model number (□□□). Position Control Unit cables come in two lengths: 0.5 m and 1 m (some are also available in lengths of 2 m). Servo Drive Cables also come in two lengths: 1 m and 2 m. For information on cable lengths, refer to Accessories and Cables on page 14.

**Note: 2.** Two Servo Drive Cables are required if 2-axis control is performed using one Position Control Unit.

## Cable Combinations

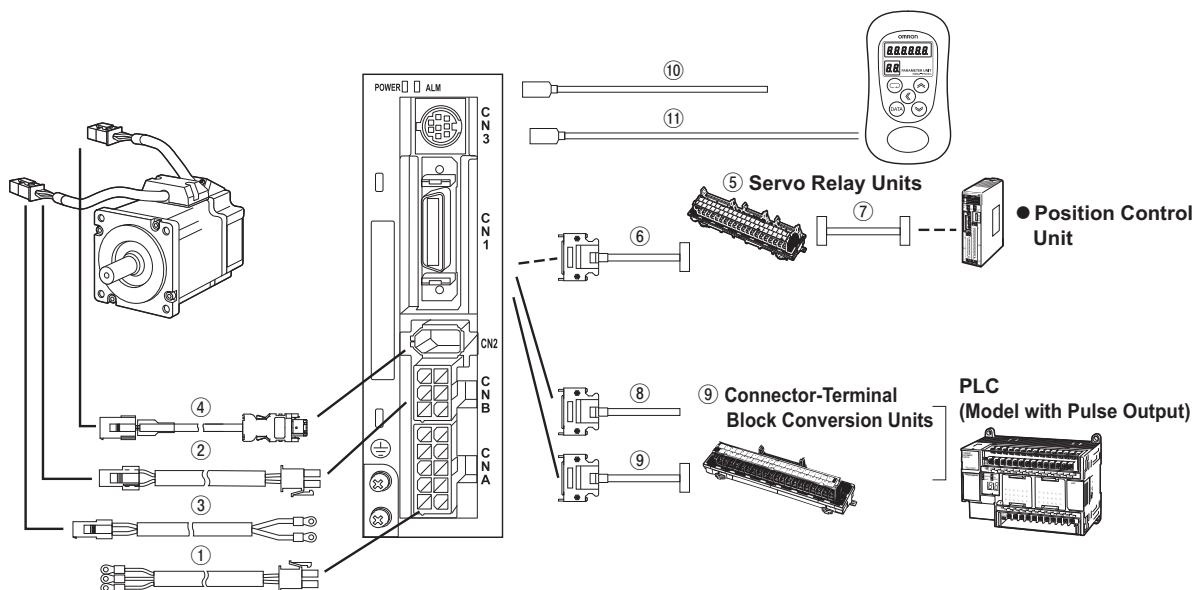

### Power Supply Cables (for CNA)

Symbol	Name	Connected to	Model	Description
①	Power Supply Input Cable for Single-Phase Power (connectors attached)	Single-phase 100 V/Single-phase 200 V R7D-BP	R7A-CLB002S2	<p>[Servo Drive Connector] Connector pins: 5556PBTL (Molex Japan Co., Ltd.) Connector case: 5557-10R-210 (Molex Japan Co., Ltd.)</p>
	Power Supply Input Cable for Three-Phase Power (connectors attached)	Three-Phase 200 V	R7A-CLB002S3	<p>[Servo Drive Connector] Connector pins: 5556PBTL (Molex Japan Co., Ltd.) Connector case: 5557-10R-210 (Molex Japan Co., Ltd.)</p>
	External Regenerative Resistor Connection Cable	Using the Servo Drive with External Regeneration Resistor Connected R88A-RR22047S R88A-RR080100S R88A-RR08050S	R7A-CLB002RG	

### Servomotor Power Cables (for CNB)

Symbol	Name	Connected to	Model	Description
②	Standard Servomotor Power Cables with Connectors	R88M-G□□□30□-□ R88M-G□□□30□-□S2 R88M-GP□□□30□-□ R88M-GP□□□30□-□S2	R7A-CAB□□□S The empty boxes in the model number are for the cable length. The cable can be 3, 5, 10, 15, or 20 m long.	<p>[Servo Drive Connector] Connector pins: 5556PBTL (Molex Japan Co., Ltd.) Connector case: 5557-06R-210 (Molex Japan Co., Ltd.)</p> <p>[Servomotor Connector] Connector pins: 170366-1 or 170362-1 (Tyco Electronics AMP KK) Connector case: 172159-1 (Tyco Electronics AMP KK)</p>
	Robot Servomotor Power Cables with Connectors	R88M-G□□□30□-□ R88M-G□□□30□-□S2 R88M-GP□□□30□-□ R88M-GP□□□30□-□S2	Available soon	—

### Brake Cables

Symbol	Name	Connected to	Model	Description
③	Standard Brake Cables	R88M-G□□□30□-B R88M-G□□□30□-BS2 R88M-GP□□□30□-B R88M-GP□□□30□-BS2	R88A-CAGA□□□B The empty boxes in the model number are for the cable length. The cable can be 3, 5, 10, 15, or 20 m long.	<p>[Servomotor Connector] Connector pins: 170366-1 or 170362-1 (Tyco Electronics AMP KK) Connector case: 172157-1 (Tyco Electronics AMP KK)</p>
	Robot Brake Cables	R88M-G□□□30□-B R88M-G□□□30□-BS2 R88M-GP□□□30□-B R88M-GP□□□30□-BS2	Available soon	—

● Encoder Cables (for CN2)

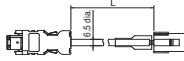
Symbol	Name	Connected to	Model	Description
④	Standard Encoder Cables with Connectors	R88M-G□□□30□-□ R88M-G□□□30□-□S2 R88M-GP□□□30□-□ R88M-GP□□□30□-□S2	R88A-CRGB□□□C The empty boxes in the model number are for the cable length. The cable can be 3, 5, 10, 15, or 20 m long.	<div style="display: flex; justify-content: space-between;"> <div style="width: 45%;"> <p><b>[Servo Drive Connector]</b> Connector pins: 50639-8028 (Molex Japan Co., Ltd.) Connector case: Crimped I/O connector: (Molex Japan Co., Ltd.)</p> </div> <div style="width: 10%; text-align: center;">  </div> <div style="width: 45%;"> <p><b>[Servomotor Connector]</b> Connector pins: 170365-1 (Tyco Electronics AMP KK) Connector case: 172160-1 (Tyco Electronics AMP KK)</p> </div> </div>
	Robot Encoder Cables with Connectors	R88M-□□□30□-□ R88M-G□□□30□-□S2 R88M-GP□□□30□-□ R88M-GP□□□30□-□S2	Available soon	—

● Control Cables (for CN1)

Symbol	Name	Connected to	Model
⑤	Servo Relay Units	CJ1W-NC113/NC133 CS1W-NC113/NC133 C200HW-NC113	XW2B-20J6-1B
		CJ1W-NC213/NC233/NC413/NC433 CS1W-NC213/NC233/NC413/NC433 C200HW-NC213/NC413	XW2B-40J6-2B
		CJ1M-CPU21/CPU22/CPU23 (one axis)	XW2B-20J6-8A
		CJ1M-CPU21/CPU22/CPU23 (two axes)	XW2B-40J6-9A
		FQM1-MMP22	XW2B-80J7-12A
		CQM1H-PLB21	XW2B-20J6-3B
⑥	Servo Drive Cables	Position Control Unit/CQM1H (XW2B-□J6-□B)	XW2Z-□□□J-B29 The empty boxes in the model number are for the cable length. The cable can be 1, or 2 m long.
		CJ1M (XW2B-□J6-□A)	XW2Z-□□□J-B32 The empty boxes in the model number are for the cable length. The cable can be 1, or 2 m long.
		FQM1-MMP22 (XW2B-80J7-12A)	XW2Z-□□□J-B30 The empty boxes in the model number are for the cable length. The cable can be 1, or 2 m long.
⑦	Position Control Units Cables	CJ1W-NC133	XW2Z-□□□J-A18 The empty boxes in the model number are for the cable length. The cable can be 0.5, or 1 m long.
		CJ1W-NC233/NC433	XW2Z-□□□J-A19 The empty boxes in the model number are for the cable length. The cable can be 0.5, or 1 m long.
		CS1W-NC133	XW2Z-□□□J-A10 The empty boxes in the model number are for the cable length. The cable can be 0.5, or 1 m long.
		CS1W-NC233/NC433	XW2Z-□□□J-A11 The empty boxes in the model number are for the cable length. The cable can be 0.5, or 1 m long.
		CJ1W-NC113	XW2Z-□□□J-A14 The empty boxes in the model number are for the cable length. The cable can be 0.5, or 1 m long.
		CJ1W-NC213/NC413	XW2Z-□□□J-A15 The empty boxes in the model number are for the cable length. The cable can be 0.5, or 1 m long.
		CS1W-NC113 C200HW-NC113	XW2Z-□□□J-A6 The empty boxes in the model number are for the cable length. The cable can be 0.5, or 1 m long.
		CS1W-NC213/NC413 C200HW-NC213/NC413	XW2Z-□□□J-A7 The empty boxes in the model number are for the cable length. The cable can be 0.5, or 1 m long.
		CJ1M-CPU21/CPU22/CPU23	XW2Z-□□□J-A33 The empty boxes in the model number are for the cable length. The cable can be 0.5, or 1 m long.
		FQM1-MMP22 (General-purpose I/O Cable)	XW2Z-□□□J-A28 The empty boxes in the model number are for the cable length. The cable can be 0.5, 1m, or 2 m long.
		FQM1-MMP22 (Special I/O Cable)	XW2Z-□□□J-A30 The empty boxes in the model number are for the cable length. The cable can be 0.5, 1m, or 2 m long.
		CQM1H-PLB21	XW2Z-□□□J-A3 The empty boxes in the model number are for the cable length. The cable can be 0.5, or 1 m long.
⑧	General-purpose Control Cables	Cables for General-purpose Controllers	R7A-CPB□□□S The empty boxes in the model number are for the cable length. The cable can be 1, or 2 m long.
⑨	Connector Terminal Block Cables	Cables for General-purpose Controllers	XW2Z-□□□J-B28 The empty boxes in the model number are for the cable length. The cable can be 1, or 2 m long.
	Connector-Terminal Block Conversion Units	Conversion Unit for General-purpose Controllers (M3 screws)	XW2B-34G4
		Conversion Unit for General-purpose Controllers (M3.5 screws)	XW2B-34G5
		Conversion Unit for General-purpose Controllers (M3 screws)	XW2D-34G6

● Communications Cables (for CN3)

Symbol	Name	Connected to	Model
⑩	Personal Computer Monitor Cable (2 m)	Windows	R88A-CCG002P2
⑪	Parameter Unit	—	R88A-PR02G

## Servo Drive Specifications (R7D-B)

### ● General Specifications

Item		Specifications
Ambient operating temperature Ambient operating humidity		0 to 55°C, 90% max. (with no condensation)
Ambient storage temperature Ambient storage humidity		-20 to 65°C, 90% max. (with no condensation)
Storage and operating atmosphere		No corrosive gasses, no dust, no iron dust, no exposure to moisture or cutting oil
Vibration resistance		10 to 60 Hz; acceleration: 5.9 m/s <sup>2</sup> (0.6 G) max.
Impact resistance		Acceleration of 19.6 m/s <sup>2</sup> max. 3 times each in X, Y, and Z directions.
Insulation resistance		Between power supply/power line terminals and frame ground: 0.5 MΩ min. (at 500 VDC)
Dielectric strength		Between power supply/power line terminals and frame ground: 1,500 VAC for 1 min at 50/60 Hz Between each control signal and frame ground: 500 VAC for 1 min
Altitude		1,000 m above sea level max. (860 hp min.)
Degree of protection		Built into panel (IP10).
International standards	EC Directives	EMC Directive
		Low Voltage Directive
	UL standards	UL 508C
	cUL standards	cUL C22.2 No.14

Note: 1. The above items reflect individual evaluation testing. The results may differ under compound conditions.

Note: 2. Depending on the operating conditions, some Servo Drive parts will require maintenance.

Note: 3. The service life of the Servo Drive is 50,000 hours at an average ambient temperature of 40°C at 80% of the rated torque (excluding axial-flow fan).

### ● Characteristics

#### 100 VAC specification

Item	Servo Drive model		
	R7D-BPA5L	R7D-BP01L	R7D-BP02L
Continuous output current (rms)	1.0 A	1.6 A	2.5 A
Momentary maximum output current (rms)	3.3 A	5.1 A	7.5 A
Power supply capacity	0.16 KVA	0.25 KVA	0.42 KVA
Input power supply voltage (main circuit)	Single-phase 100 to 115 VAC (85 to 127 V), 50/60 Hz		
Input power supply current (rms) (main circuit)	1.4 A	2.2 A	3.7 A
Heat generated (main circuit)	12 W	16 W	22 W
Control method	All-digital servo		
Inverter method	IGBT-driven PWM method		
PWM frequency	12 kHz		6 kHz
Maximum response frequency (command pulses)	Line drive: 500 kpps, Open collector: 200 kpps		
Weight	0.35 kg		0.42 kg
Applicable motor capacity	50 W	100 W	200 W

#### 200 VAC specification

Item	Servo Drive model			
	R7D-BP01H	R7D-BP02HH	R7D-BP02H	R7D-BP04H
Continuous output current (rms)	1.0 A	1.6 A	1.6 A	2.5 A
Momentary maximum output current (rms)	3.3 A	4.9 A	4.9 A	7.8 A
Power supply capacity	0.27 KVA (0.30 KVA) See note	0.35 KVA	0.42 KVA	0.69 KVA (0.77 KVA) See note
Input power supply voltage (main circuit)	Both single-phase and three-phase 200 to 240 VAC (170 to 264 V), 50/60 Hz			
Input power supply current (rms) (main circuit)	0.7 A (1.5 A) See note	1.6 A	1.1 A	1.8 A (3.5 A) See note
Heat generated (main circuit)	14 W	16 W	20 W	26 W
Control method	All-digital servo			
Inverter method	IGBT-driven PWM method			
PWM frequency	12 kHz			6 kHz
Maximum response frequency (command pulses)	Line drive: 500 kpps, Open collector: 200 kpps			
Weight	0.35 kg		0.42 kg	
Applicable motor capacity	100 W	200 W	200 W	400 W

Note: Values inside parentheses ( ) are for single-phase 200-V use.

## Servomotor Specifications (R88M-G)

### ● General Specifications

Item		Specifications
Ambient operating temperature Ambient operating humidity		0 to 40°C, 85% max. (with no condensation)
Ambient storage temperature Ambient storage humidity		-20 to 65°C, 85% max. (with no condensation)
Storage and operating atmosphere		No corrosive gases
Vibration resistance		49 m/s <sup>2</sup> max. in the X, Y, and Z directions
Impact resistance		Acceleration of 98 m/s <sup>2</sup> max. 3 times each in the X, Y, and Z directions
Insulation resistance		20 MΩ min. at 500 VDC between the power terminals and FG terminal
Dielectric strength		1,500 VAC (50 or 60 Hz) for 1 minute between the power terminals and FG terminal
Operating position		Any direction
Insulation class		Type B
Construction		Totally-enclosed, self-cooling
Degree of protection		IP65 (excluding the through-shaft portion)
Vibration class		V-15
Mounting method		Flange-mounting
International standards	EC Directives	EMC Directive EN 60034-1:2004
		Low Voltage Directive IEC 60034-5:2001
	UL standards	UL 1004 File No. E179189
	cUL standards	cUL 22.2, No.100

● Characteristics

3,000-r/min Cylindrical Servomotors  
100 VAC specification

Item		Unit	R88M-G05030H	R88M-G10030L	R88M-G20030L
Rated output <sup>*1</sup>		W	50	100	200
Rated torque <sup>*1</sup>		N·m	0.16	0.32	0.64
Rated rotation speed		r/min	3000		
Max. rotation speed		r/min	5000		
Max. momentary torque <sup>*1</sup>		N·m	0.48	0.95	1.78
Rated current <sup>*1</sup>		A (rms)	1.1	1.7	2.5
Max. momentary current <sup>*1</sup>		A (rms)	3.4	5.1	7.6
Rotor inertia		kg·m <sup>2</sup>	2.5 × 10 <sup>-6</sup>	5.1 × 10 <sup>-6</sup>	1.4 × 10 <sup>-5</sup>
Applicable load inertia		---	30 times rotor inertia max.		
Power rate <sup>*1</sup>		kW/s	10.4	20.1	30.3
Allowable radial load <sup>*2</sup>		N	68	68	245
Allowable thrust load <sup>*2</sup>		N	58	58	98
Weight	Without brake	kg	0.3	0.5	0.8
	With brake	kg	0.5	0.7	1.3
Radiation shield dimensions (material)		---	100 × 80 × t10 (Al)		130 × 120 × t12 (Al)
Brake specifications	Brake inertia	kg·m <sup>2</sup>	2.0 × 10 <sup>-7</sup>	2.0 × 10 <sup>-7</sup>	1.8 × 10 <sup>-6</sup>
	Excitation voltage <sup>*3</sup>	V	24 VDC ±10%		
	Power consumption (at 20°C)	W	7	7	9
	Current consumption (at 20°C)	A	0.30	0.30	0.36
	Static friction torque	N·m	0.29 min.	0.29 min.	1.27 min.
	Attraction time <sup>*4</sup>	ms	35 max.	35 max.	50 max.
	Release time <sup>*4</sup>	ms	20 max.	20 max.	15 max.
	Backlash		±1° max.		
	Allowable work per braking operation	J	39.2	39.2	137
	Allowable total work	J	4.9 × 10 <sup>3</sup>	4.9 × 10 <sup>3</sup>	44.1 × 10 <sup>3</sup>
Allowable angular acceleration	rad/s <sup>2</sup>	30,000 max. (Speed of 2,800 r/min minimum must not be stopped in less than 10 ms)			
Brake life	---	10,000,000 operations min.			
Rating	---	Continuous			

- \* 1. These are the values when the Servomotor is combined with a Servo Drive at room temperature. The momentary maximum torque shown above indicates the standard value.
- \* 2. The allowable radial and thrust loads are the values determined for a service life of 20,000 hours at normal operating temperatures. The values are also for the locations shown in the following diagram.
- \* 3. The brakes operate when the circuit is open (i.e., they are released when voltage is applied).
- \* 4. The operation time is the measured value (reference value) with a varistor installed as a surge suppressor.

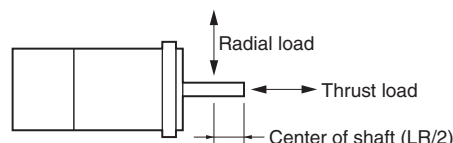

Torque and Rotation Speed Characteristics

● 3,000-r/min Cylindrical Servomotors

The following graphs show the characteristics with a 3-m standard cable and a 100-VAC input.

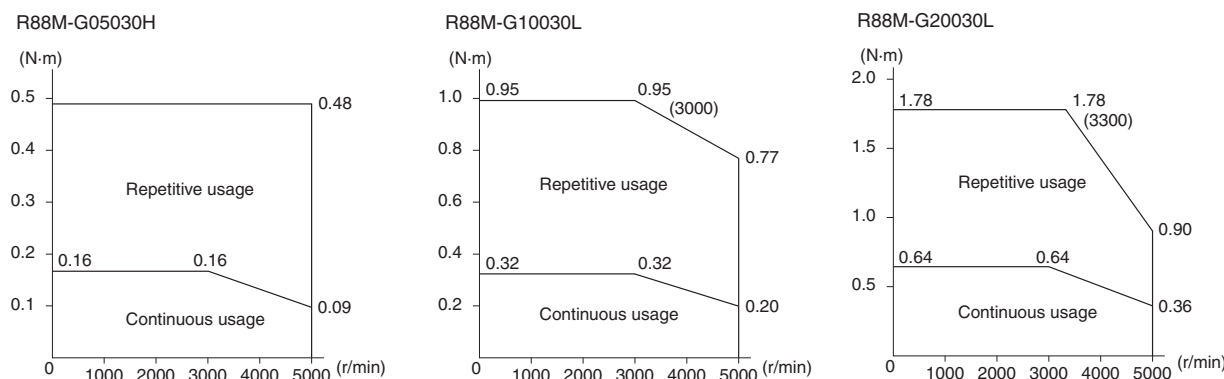

## Servomotor Specifications (R88M-G)

### ● Characteristics

#### 3,000-r/min Cylindrical Servomotors

#### 200 VAC specification

Item	Unit	R88M-G05030H	R88M-G10030H	R88M-G20030H	R88M-G40030H	
Rated output <sup>*1</sup>	W	50	100	200	400	
Rated torque <sup>*1</sup>	N·m	0.16	0.32	0.64	1.3	
Rated rotation speed	r/min	3000				
Max. rotation speed	r/min	5000				
Max. momentary torque <sup>*1</sup>	N·Em	0.48	0.95	1.78	3.60	
Rated current <sup>*1</sup>	A (rms)	1.1	1.1	1.6	2.6	
Max. momentary current <sup>*1</sup>	A (rms)	3.4	3.4	4.9	7.9	
Rotor inertia	kg·m <sup>2</sup>	2.5 × 10 <sup>-6</sup>	5.1 × 10 <sup>-6</sup>	1.4 × 10 <sup>-5</sup>	2.6 × 10 <sup>-5</sup>	
Applicable load inertia	---	30 times rotor inertia max.				
Power rate <sup>*1</sup>	kW/s	10.4	20.1	30.3	62.5	
Allowable radial load <sup>*2</sup>	N	68	68	245	245	
Allowable thrust load <sup>*2</sup>	N	58	58	98	98	
Weight	Without brake	kg	0.3	0.5	0.8	1.2
	With brake	kg	0.5	0.7	1.3	1.7
Radiation shield dimensions (material)	---	100 × 80 × t10 (Al)		130 × 120 × t12 (Al)		
Brake specifications	Brake inertia	kg·m <sup>2</sup>	2.0 × 10 <sup>-7</sup>	2.0 × 10 <sup>-7</sup>	1.8 × 10 <sup>-6</sup>	7.5 × 10 <sup>-6</sup>
	Excitation voltage <sup>*3</sup>	V	24 VDC ±10%			
	Power consumption (at 20°C)	W	7	7	9	9
	Current consumption (at 20°C)	A	0.30	0.30	0.36	0.36
	Static friction torque	N·m	0.29 min.	0.29 min.	1.27 min.	1.27 min.
	Attraction time <sup>*4</sup>	ms	35 max.	35 max.	50 max.	50 max.
	Release time <sup>*4</sup>	ms	20 max.	20 max.	15 max.	15 max.
	Backlash		±1° max.			
	Allowable work per braking operation	J	39.2	39.2	137	196
	Allowable total work	J	4.9 × 10 <sup>3</sup>	4.9 × 10 <sup>3</sup>	44.1 × 10 <sup>3</sup>	147 × 10 <sup>3</sup>
	Allowable angular acceleration	rad/s <sup>2</sup>	30,000 max. (Speed of 2,800 r/min minimum must not be stopped in less than 10 ms)			
	Brake life	---	10,000,000 operations min.			
Rating	---	Continuous				

- \* 1. These are the values when the Servomotor is combined with a Servo Drive at room temperature. The momentary maximum torque shown above indicates the standard value.
- \* 2. The allowable radial and thrust loads are the values determined for a service life of 20,000 hours at normal operating temperatures. The values are also for the locations shown in the following diagram.
- \* 3. The brakes operate when the circuit is open (i.e., they are released when voltage is applied).
- \* 4. The operation time is the measured value (reference value) with a varistor installed as a surge suppressor.

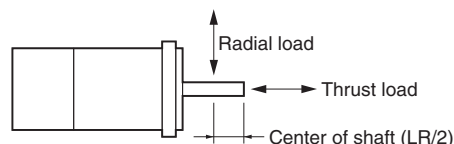

## Torque and Rotation Speed Characteristics

### ● 3,000-r/min Cylindrical Servomotors

The following graphs show the characteristics with a 3-m standard cable and a 200-VAC input.

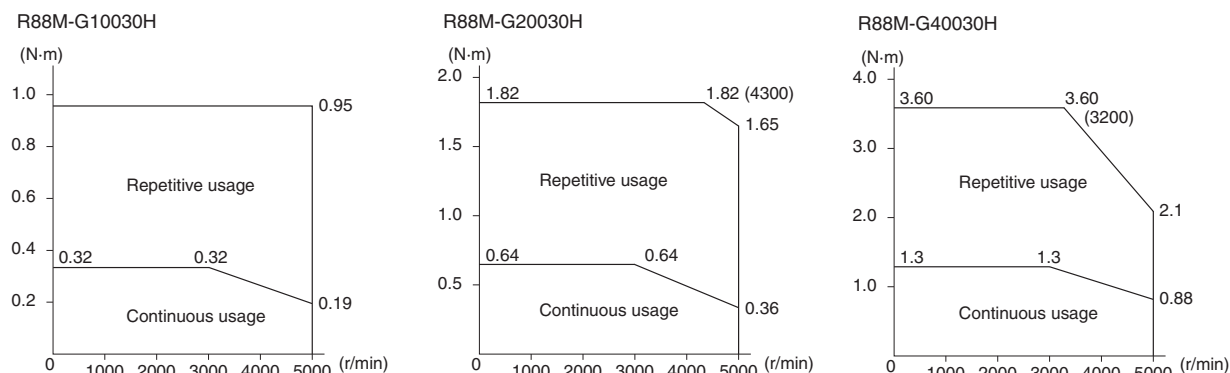

## Servomotor Specifications (R88M-G)

### ● 3,000-r/min Flat Servomotors

#### 100 VAC specification

Item		Unit	R88M-GP10030L	R88M-GP20030L
Rated output <sup>*1</sup>		W	100	200
Rated torque <sup>*1</sup>		N·m	0.32	0.64
Rated rotation speed		r/min	3,000	
Max. rotation speed		r/min	5,000	
Max. momentary torque <sup>*1</sup>		N·m	0.85	1.86
Rated current <sup>*1</sup>		A(rms)	1.6	2.5
Max. momentary current <sup>*1</sup>		A(0-p)	6.9	10.5
Rotor inertia		kg·m <sup>2</sup>	9.0 × 10 <sup>-6</sup>	3.4 × 10 <sup>-5</sup>
Applicable load inertia		---	20 times rotor inertia max.	
Power rate <sup>*1</sup>		kW/s	11.4	12.0
Allowable radial load <sup>*2</sup>		N	68	245
Allowable thrust load <sup>*2</sup>		N	58	98
Weight	Without brake	kg	0.65	1.3
	With brake	kg	0.90	2.0
Radiation shield dimensions (material)		---	130 × 120 × t10 (Al)	170 × 160 × t12 (Al)
Brake specifications	Brake inertia	kg·m <sup>2</sup>	3.0 × 10 <sup>-6</sup>	9.0 × 10 <sup>-6</sup>
	Excitation voltage <sup>*3</sup>	V	24 VDC ±10%	
	Power consumption (at 20°C)	W	7	10
	Current consumption (at 20°C)	A	0.29	0.41
	Static friction torque	N·m	0.29 min.	1.27 min.
	Attraction time <sup>*4</sup>	ms	50 max.	60 max.
	Release time <sup>*4</sup>	ms	15 max.	15 max.
	Backlash		±1° max.	
	Allowable work per braking operation	J	137	196
	Allowable total work	J	44.1 × 10 <sup>3</sup>	147 × 10 <sup>3</sup>
	Allowable angular acceleration	rad/s <sup>2</sup>	10,000 max. (Speed of 950 r/min minimum must not be stopped in less than 10 ms)	
	Brake life	---	10,000,000 operations min.	
Rating	---	Continuous		

- \* 1. These are the values when the Servomotor is combined with a Servo Drive at room temperature. The momentary maximum torque shown above indicates the standard value.
- \* 2. The allowable radial and thrust loads are the values determined for a service life of 20,000 hours at normal operating temperatures. The values are also for the locations shown in the following diagram.
- \* 3. The brakes operate when the circuit is open (i.e., they are released when voltage is applied).
- \* 4. The operation time is the measured value (reference value) with a varistor installed as a surge suppressor.

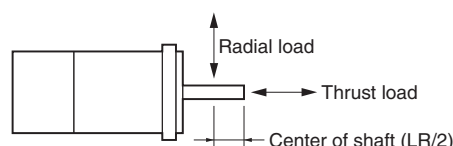

## Torque and Rotation Speed Characteristics

### ● 3,000-r/min Flat Servomotors

The following graphs show the characteristics with a 3-m standard cable and a 100-VAC input.

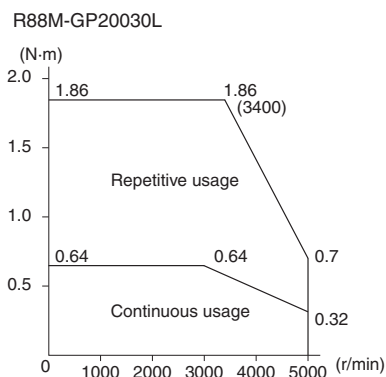
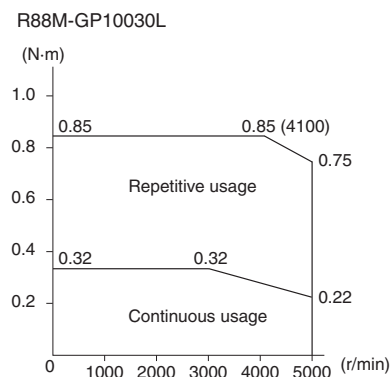

## Servomotor Specifications (R88M-G)

### ● 3,000-r/min Flat Servomotors

#### 200 VAC specification

Item	Unit	R88M-GP10030H	R88M-GP20030H	R88M-GP40030H	
Rated output *1	W	100	200	400	
Rated torque *1	N·m	0.32	0.64	1.3	
Rated rotation speed	r/min	3000			
Max. rotation speed	r/min	5000			
Max. momentary torque *1	N·m	0.90	1.82	3.60	
Rated current *1	A(rms)	1.0	1.6	4.4	
Max. momentary current *1	A(0-p)	4.3	6.8	18.6	
Rotor inertia	kg·m <sup>2</sup>	9.0 × 10 <sup>-6</sup>	3.4 × 10 <sup>-5</sup>	6.4 × 10 <sup>-5</sup>	
Applicable load inertia	---	20 times rotor inertia max.			
Power rate *1	kW/s	11.4	11.8	25.5	
Allowable radial load *2	N	68	245	245	
Allowable thrust load *2	N	58	98	98	
Weight	Without brake	kg	0.7	1.3	
	With brake	kg	0.9	2.0	
Radiation shield dimensions (material)	---	130 × 120 × t10 (Al)	170 × 160 × t12 (Al)		
Brake specifications	Brake inertia	kg·m <sup>2</sup>	3.0 × 10 <sup>-6</sup>	9.0 × 10 <sup>-6</sup>	9.0 × 10 <sup>-6</sup>
	Excitation voltage *3	V	24 VDC ±10%		
	Power consumption (at 20°C)	W	7	10	10
	Current consumption (at 20°C)	A	0.29	0.41	0.41
	Static friction torque	N·m	0.29 min.	1.27 min.	1.27 min.
	Attraction time *4	ms	50 max.	60 max.	60 max.
	Release time *4	ms	15 max.	15 max.	15 max.
	Backlash		±1° max.		
	Allowable work per braking operation	J	137	196	196
	Allowable total work	J	44.1 × 10 <sup>3</sup>	147 × 10 <sup>3</sup>	147 × 10 <sup>3</sup>
	Allowable angular acceleration	rad/s <sup>2</sup>	10,000 max. (Speed of 950 r/min minimum must not be stopped in less than 10 ms)		
Brake life	---	10,000,000 operations min.			
Rating	---	Continuous			

- \* 1. These are the values when the Servomotor is combined with a Servo Drive at room temperature. The momentary maximum torque shown above indicates the standard value.
- \* 2. The allowable radial and thrust loads are the values determined for a service life of 20,000 hours at normal operating temperatures. The values are also for the locations shown in the following diagram.
- \* 3. The brakes operate when the circuit is open (i.e., they are released when voltage is applied).
- \* 4. The operation time is the measured value (reference value) with a varistor installed as a surge suppressor.

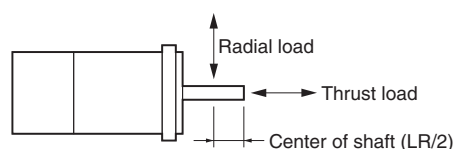

## Torque and Rotation Speed Characteristics

### ● 3,000-r/min Flat Servomotors

The following graphs show the characteristics with a 3-m standard cable and a 200-VAC input.

R88M-GP10030H

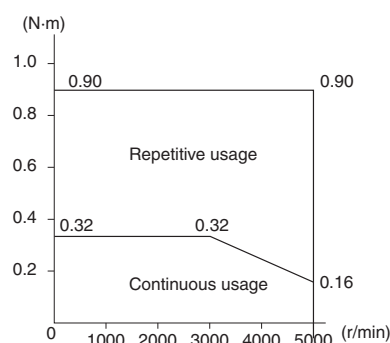

R88M-GP20030H

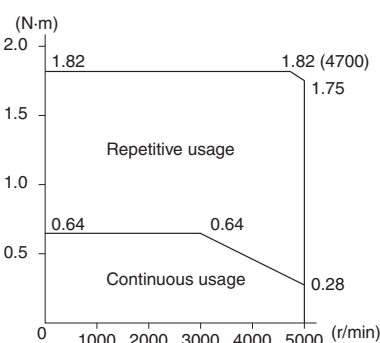

R88M-GP40030H

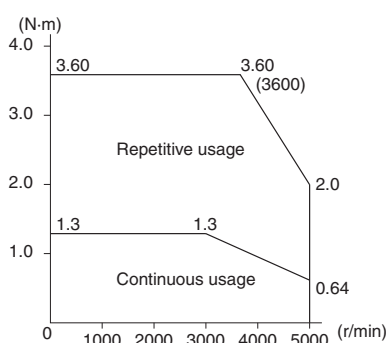

## Decelerator Specifications

### Standard Models and Specifications

● Backlash: 3 Arcminutes Max.

#### Decelerators for Cylindrical Servomotors

Model (R88G-)			Rated speed	Rated torque	Ratio	Maximum momentary speed	Maximum momentary torque	Decelerator inertia	Allowable radial load	Allowable thrust load	Weight
			r/min	N-m	%	r/min	N-m	kg-m <sup>2</sup>	N	N	kg
50 W	1/5	HPG11A05100B	600	0.60	75	1000	1.80	5.00×10 <sup>-7</sup>	135	538	0.29
	1/9	HPG11A09050B	333	1.17	81	555	3.51	3.00×10 <sup>-7</sup>	161	642	0.29
	1/21	HPG14A21100B	143	2.18	65	238	6.54	5.00×10 <sup>-6</sup>	340	1358	1.04
	1/33	HPG14A33050B	91	3.73	71	151	11.2	4.40×10 <sup>-6</sup>	389	1555	1.04
	1/45	HPG14A45050B	67	5.09	71	111	15.2	4.40×10 <sup>-6</sup>	427	1707	1.04
100 W	1/5	HPG11A05100B	600	1.37	86	1000	4.07	5.00×10 <sup>-7</sup>	135	538	0.29
	1/11	HPG14A11100B	273	2.63	75	454	7.80	6.00×10 <sup>-6</sup>	280	1119	1.04
	1/21	HPG14A21100B	143	5.40	80	238	16.0	5.00×10 <sup>-6</sup>	340	1358	1.04
	1/33	HPG20A33100B	91	6.91	65	151	20.5	6.50×10 <sup>-5</sup>	916	3226	2.4
	1/45	HPG20A45100B	67	9.42	65	111	27.9	6.50×10 <sup>-5</sup>	1006	3541	2.4
200 W	1/5	HPG14A05200B	600	2.49	78	1000	7.44	2.07×10 <sup>-5</sup>	221	883	1.02
	1/11	HPG14A11200B	273	6.01	85	454	17.9	1.93×10 <sup>-5</sup>	280	1119	1.09
	1/21	HPG20A21200B	143	10.2	76	238	30.6	4.90×10 <sup>-5</sup>	800	2817	2.9
	1/33	HPG20A33200B	91	17.0	81	151	50.8	4.50×10 <sup>-5</sup>	916	3226	2.9
	1/45	HPG20A45200B	67	23.2	81	111	69.3	4.50×10 <sup>-5</sup>	1006	3541	2.9
400 W	1/5	HPG14A05400B	600	5.66	87	1000	16.5	2.07×10 <sup>-5</sup>	221	883	1.09
	1/11	HPG20A11400B	273	11.7	82	454	34.2	5.70×10 <sup>-5</sup>	659	2320	2.9
	1/21	HPG20A21400B	143	23.5	86	238	68.8	4.90×10 <sup>-5</sup>	800	2547	2.9
	1/33	HPG32A33400B	91	34.7	81	151	101.7	6.20×10 <sup>-5</sup>	1565	6240	7.5
	1/45	HPG32A45400B	67	47.4	81	111	138.6	6.10×10 <sup>-5</sup>	1718	6848	7.5

Note: 1. The Decelerator inertia is the Servomotor shaft conversion value.

Note: 2. The enclosure rating for Servomotors with Decelerators is IP44.

Note: 3. The allowable radial load is the value at the LR/2 position.

Note: 4. The standard models have a straight shaft. To order a Servomotor with a straight shaft with a key, add a "J" to the end of the model number, in the place indicated by the box.

#### Decelerator for Flat Servomotors

Model (R88G-)			Rated speed	Rated torque	Ratio	Maximum momentary speed	Maximum momentary torque	Decelerator inertia	Allowable radial load	Allowable thrust load	Weight
			r/min	N-m	%	r/min	N-m	kg-m <sup>2</sup>	N	N	kg
100 W	1/5	HPG11A05100PB	600	1.37	85	1000	3.84 (3.63)	5.00×10 <sup>-7</sup>	135	538	0.34
	1/11	HPG14A11100PB	273	2.63	75	454	7.39 (6.98)	6.00×10 <sup>-6</sup>	280	1119	1.04
	1/21	HPG14A21100PB	143	5.40	80	238	15.2 (14.6)	5.00×10 <sup>-6</sup>	340	1358	1.04
	1/33	HPG20A33100PB	91	6.91	65	151	19.4 (18.3)	4.50×10 <sup>-5</sup>	916	3226	2.9
	1/45	HPG20A45100PB	67	9.42	65	111	26.5 (25.0)	4.50×10 <sup>-5</sup>	1006	3541	2.9
200 W	1/5	HPG14A05200PB	600	2.49	78	1000	7.09	2.07×10 <sup>-5</sup>	221	883	0.99
	1/11	HPG20A11200PB	273	4.75	68	454	13.5	5.80×10 <sup>-5</sup>	659	2320	3.1
	1/21	HPG20A21200PB	143	10.2	76	238	29.2	4.90×10 <sup>-5</sup>	800	2817	3.1
	1/33	HPG20A33200PB	91	17.0	81	151	48.5	4.50×10 <sup>-5</sup>	916	3226	3.1
	1/45	HPG20A45200PB	67	23.2	81	111	66.1	4.50×10 <sup>-5</sup>	1006	3541	3.1
400 W	1/5	HPG20A05400PB	600	4.67	72	1000	12.9	7.10×10 <sup>-5</sup>	520	1832	3.1
	1/11	HPG20A11400PB	273	11.7	82	454	32.4	5.80×10 <sup>-5</sup>	659	2320	3.1
	1/21	HPG20A21400PB	143	23.5	86	238	65.2	4.90×10 <sup>-5</sup>	800	2817	3.1
	1/33	HPG32A33400PB	91	34.7	81	151	96.2	2.80×10 <sup>-4</sup>	1565	6240	7.8
	1/45	HPG32A45400PB	67	47.4	81	111	131.2	2.80×10 <sup>-4</sup>	1718	6848	7.8

Note: 1. The Decelerator inertia is the Servomotor shaft conversion value.

Note: 2. The enclosure rating for Servomotors with Decelerators is IP44.

Note: 3. The allowable radial load is the value at the LR/2 position.

Note: 4. The standard models have a straight shaft. To order a Servomotor with a straight shaft with a key, add a "J" to the end of the model number, in the place indicated by the box.

Note: 5. The values inside parentheses ( ) are those when using a 100-V motor.

● Backlash: 15 Arcminutes Max.

Decelerators for Cylindrical Servomotors

Model (R88G-)			Rated speed	Rated torque	Ratio	Maximum momentary speed	Maximum momentary torque	Decelerator inertia	Allowable radial load	Allowable thrust load	Weight
			r/min	N-m	%	r/min	N-m	kg-m <sup>2</sup>	N	N	kg
50 W	1/5	VRSF05B100CJ	600	0.52	65	1000	1.55	4.00×10 <sup>-6</sup>	392	196	0.55
	1/9	VRSF09B100CJ	333	0.93	65	556	2.79	3.50×10 <sup>-6</sup>	441	220	0.55
	1/15	VRSF15B100CJ	200	1.67	70	333	5.01	3.50×10 <sup>-6</sup>	588	294	0.70
	1/25	VRSF25B100CJ	120	2.78	70	200	8.34	3.25×10 <sup>-6</sup>	686	343	0.70
100 W	1/5	VRSF05B100CJ	600	1.19	75	1000	3.57	4.00×10 <sup>-6</sup>	392	196	0.55
	1/9	VRSF09B100CJ	333	2.29	80	556	6.87	3.50×10 <sup>-6</sup>	441	220	0.55
	1/15	VRSF15B100CJ	200	3.81	80	333	11.4	3.50×10 <sup>-6</sup>	588	294	0.70
	1/25	VRSF25B100CJ	120	6.36	80	200	19.0	3.25×10 <sup>-6</sup>	686	343	0.70
200 W	1/5	VRSF05B200CJ	600	2.70	85	1000	8.10	1.18×10 <sup>-5</sup>	392	196	0.72
	1/9	VRSF09C200CJ	333	3.77	66	556	11.3	2.75×10 <sup>-5</sup>	931	465	1.70
	1/15	VRSF15C200CJ	200	6.29	66	333	18.8	3.00×10 <sup>-5</sup>	1176	588	2.10
	1/25	VRSF25C200CJ	120	11.1	70	200	33.3	2.88×10 <sup>-5</sup>	1323	661	2.10
400 W	1/5	VRSF05C400CJ	600	5.40	85	1000	16.2	3.63×10 <sup>-5</sup>	784	392	1.70
	1/9	VRSF09C400CJ	333	9.50	83	556	28.5	2.75×10 <sup>-5</sup>	931	465	1.70
	1/15	VRSF15C400CJ	200	15.8	83	333	47.4	3.00×10 <sup>-5</sup>	1176	588	2.10
	1/25	VRSF25C400CJ	120	26.4	83	200	79.2	2.88×10 <sup>-5</sup>	1323	661	2.10

Note: 1. The Decelerator inertia is the Servomotor shaft conversion value.

Note: 2. The enclosure rating for Servomotors with Decelerators is IP44.

Note: 3. The allowable radial load is the value at the LR/2 position.

Note: 4. The standard models have a straight shaft.

Decelerator for Flat Servomotors

Model (R88G-)			Rated speed	Rated torque	Ratio	Maximum momentary speed	Maximum momentary torque	Decelerator inertia	Allowable radial load	Allowable thrust load	Weight
			r/min	N-m	%	r/min	N-m	kg-m <sup>2</sup>	N	N	kg
100 W	1/5	VRSF05B100PCJ	600	1.19	75	1000	3.38 (3.19)	4.00×10 <sup>-6</sup>	392	196	0.72
	1/9	VRSF09B100PCJ	333	2.29	80	556	6.48 (6.12)	3.50×10 <sup>-6</sup>	441	220	0.72
	1/15	VRSF15B100PCJ	200	3.81	80	333	10.8 (10.2)	3.50×10 <sup>-6</sup>	588	294	0.87
	1/25	VRSF25B100PCJ	120	6.36	80	200	18.0 (17.0)	3.25×10 <sup>-6</sup>	686	343	0.87
200 W	1/5	VRSF05B200PCJ	600	2.70	85	1000	7.74	1.18×10 <sup>-5</sup>	392	196	0.85
	1/9	VRSF09C200PCJ	333	3.77	66	556	10.8	2.75×10 <sup>-5</sup>	931	465	1.80
	1/15	VRSF15C200PCJ	200	6.29	66	333	18.0	3.00×10 <sup>-5</sup>	1176	588	2.20
	1/25	VRSF25C200PCJ	120	11.1	70	200	31.8	2.88×10 <sup>-5</sup>	1323	661	2.20
400 W	1/5	VRSF05C400PCJ	600	5.40	85	1000	15.3	3.63×10 <sup>-5</sup>	784	392	1.80
	1/9	VRSF09C400PCJ	333	9.50	83	556	26.9	2.75×10 <sup>-5</sup>	931	465	1.80
	1/15	VRSF15C400PCJ	200	15.8	83	333	44.8	3.00×10 <sup>-5</sup>	1176	588	2.20
	1/25	VRSF25C400PCJ	120	26.4	83	200	74.7	2.88×10 <sup>-5</sup>	1323	661	2.20

Note: 1. The Decelerator inertia is the Servomotor shaft conversion value.

Note: 2. The enclosure rating for Servomotors with Decelerators is IP44.

Note: 3. The allowable radial load is the value at the LR/2 position.

Note: 4. The standard models have a straight shaft.

Note: 5. The values inside parentheses ( ) are those when using a 100-V motor.

## Encoder, External Regeneration Resistors, Reactor and Parameter Unit Specifications

### Encoder Specifications

Item	Specifications
Encoder system	Optical encoder (incremental encoder)
No. of output pulses	Phases A and B: 2,500 pulses/rotation, Phase Z: 1 pulse/rotation
Power supply voltage	5 V ±5%
Power supply current	180 mA (max.)
Output signals	+S, -S
Output interface	EIA RS-485 compliance
	Duplex serial communications data

### External Regeneration Resistors Specifications

Model	Resistance	Nominal capacity	Regeneration absorption for 120°C temperature rise	Heat radiation condition	Thermal switch output specifications
R88A-RR08050S	50 Ω	80 W	20 W	Aluminum 250 × 250, Thickness: 3.0	Operating temperature: 150°C±5%, NC contact, Rated output: 30 VDC, 50 mA max.
R88A-RR080100S	100 Ω	80 W	20 W	Aluminum 250 × 250, Thickness: 3.0	Operating temperature: 150°C±5%, NC contact, Rated output: 30 VDC, 50 mA max.
R88A-RR22047S	47 Ω	220 W	70 W	Aluminum 350 × 350, Thickness: 3.0	Operating temperature: 170°C±5%, NC contact, Rated output: 3 A

### Reactor Specifications

Reactor type	Specifications			
	Model	Rated current (A)	Inductance (mH)	Weight (kg)
Single-phase Reactors	3G3AX-DL2002	1.6 A	21.4 mH	0.8 kg
	3G3AX-DL2004	3.2 A	10.7 mH	1.0 kg
	3G3AX-DL2007	6.1 A	6.75 mH	1.3 kg
Three-phase Reactor	3G3AX-AL2025	10 A	2.8 mH	2.8 kg

### Parameter Unit Specifications

#### General Specifications

Item	Specifications
Operating ambient temperature	0 to 55°C
Operating ambient humidity	90% max. (with no condensation)
Storage ambient temperature	-20 to 80°C
Storage ambient humidity	90% max. (with no condensation)
Storage and operating atmosphere	No corrosive gases
Vibration resistance	5.9 m/s <sup>2</sup> max.

#### Performance Specifications

Item	Specifications	
Type	Hand-held	
Cable length	1.5 m	
Connectors	Mini DIN 8-pin MD connector	
Display	7-segment LED	
External dimensions	62 × 114 × 15 mm (W × H × D)	
Weight	Approx. 0.1 kg (including cable that is provided)	
Communications specifications	Standard	RS-232
	Communications method	Asynchronous (ASYNC)
	Baud rate	9,600 bps
	Start bits	1 bit
	Data	8 bits
	Parity	None
	Stop bits	1 bit

## Connections

### Peripheral Device Connection Examples

#### R7D-BPA5L/-BP01L/-BP02L/-BP04L/-BP01H/-BP02HH/-BP04H

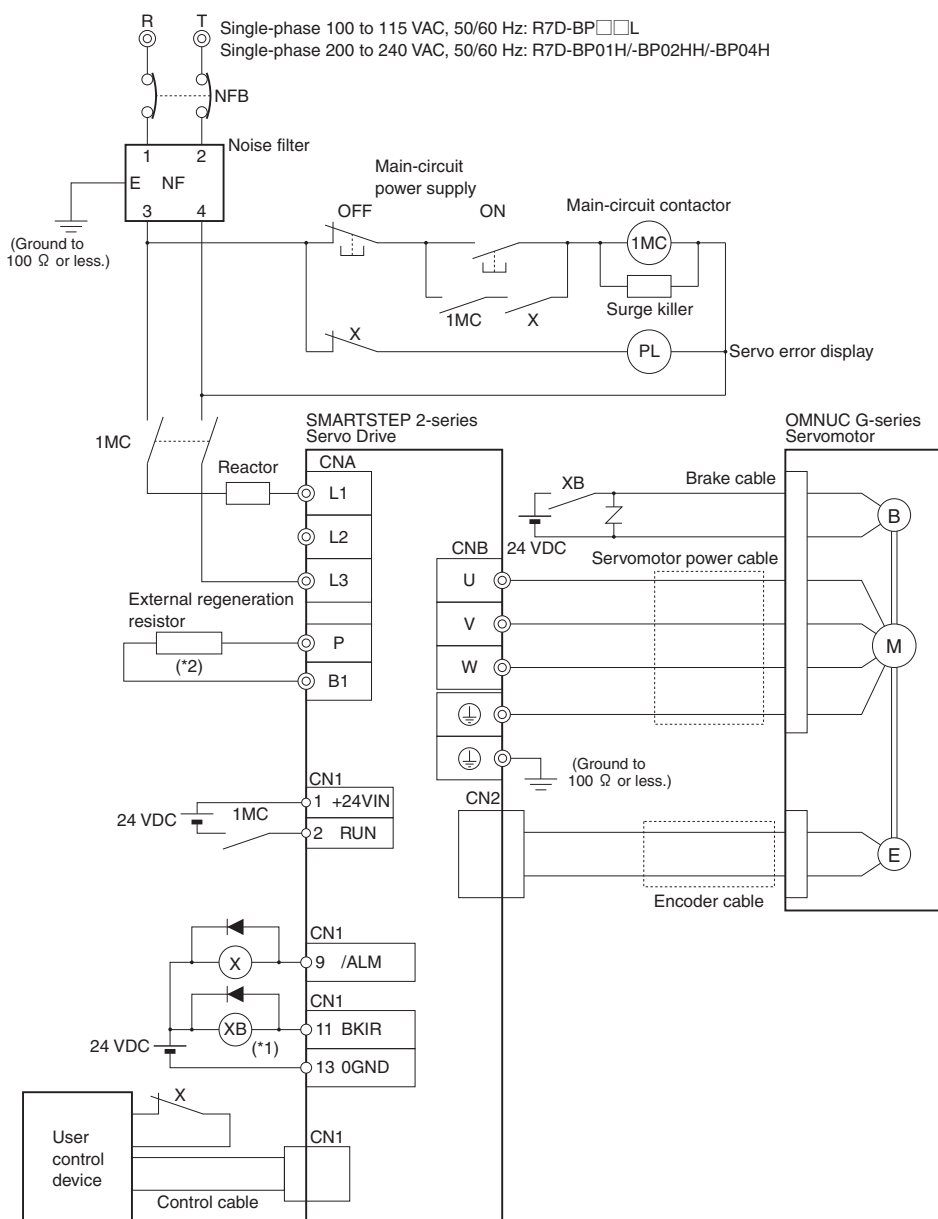

\* 1. Recommended Relay: OMRON G7T Relay (24-VDC model)

\* 2. An External Regeneration Resistor can be connected.

Connect this resistor if the regenerative energy exceeds regeneration absorption capacity in the Servo Drive.

**Note: 1.** The dynamic brake will operate while the main circuit power supply or the control circuit power supply is OFF.

**Note: 2.** When turning OFF the main circuit power supply, turn OFF the RUN Command Input (RUN) at the same time.

R7D-BP01H/-BP02H/-BP04H

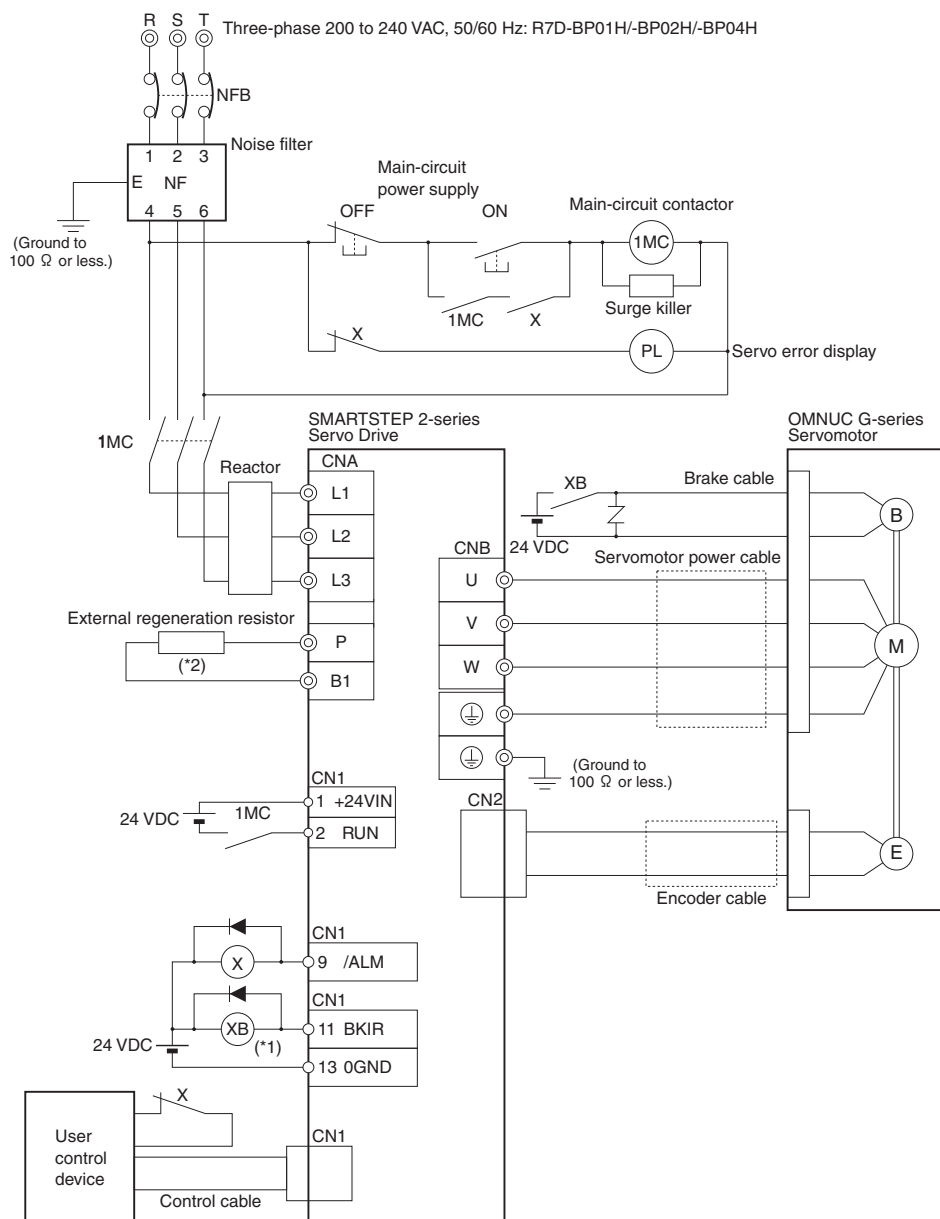

\* 1. Recommended Relay: OMRON G7T Relay (24-VDC model)

\* 2. An External Regeneration Resistor can be connected.

Connect this resistor if the regenerative energy exceeds regeneration absorption capacity in the Servo Drive.

**Note: 1.** The dynamic brake will operate while the main circuit power supply or the control circuit power supply is OFF.

**Note: 2.** When turning OFF the main circuit power supply, turn OFF the RUN Command Input (RUN) at the same time.

## I/O Circuit Diagrams

### Control I/O Specifications (CN1)

#### Control I/O Signal Connections and External Signal Processing

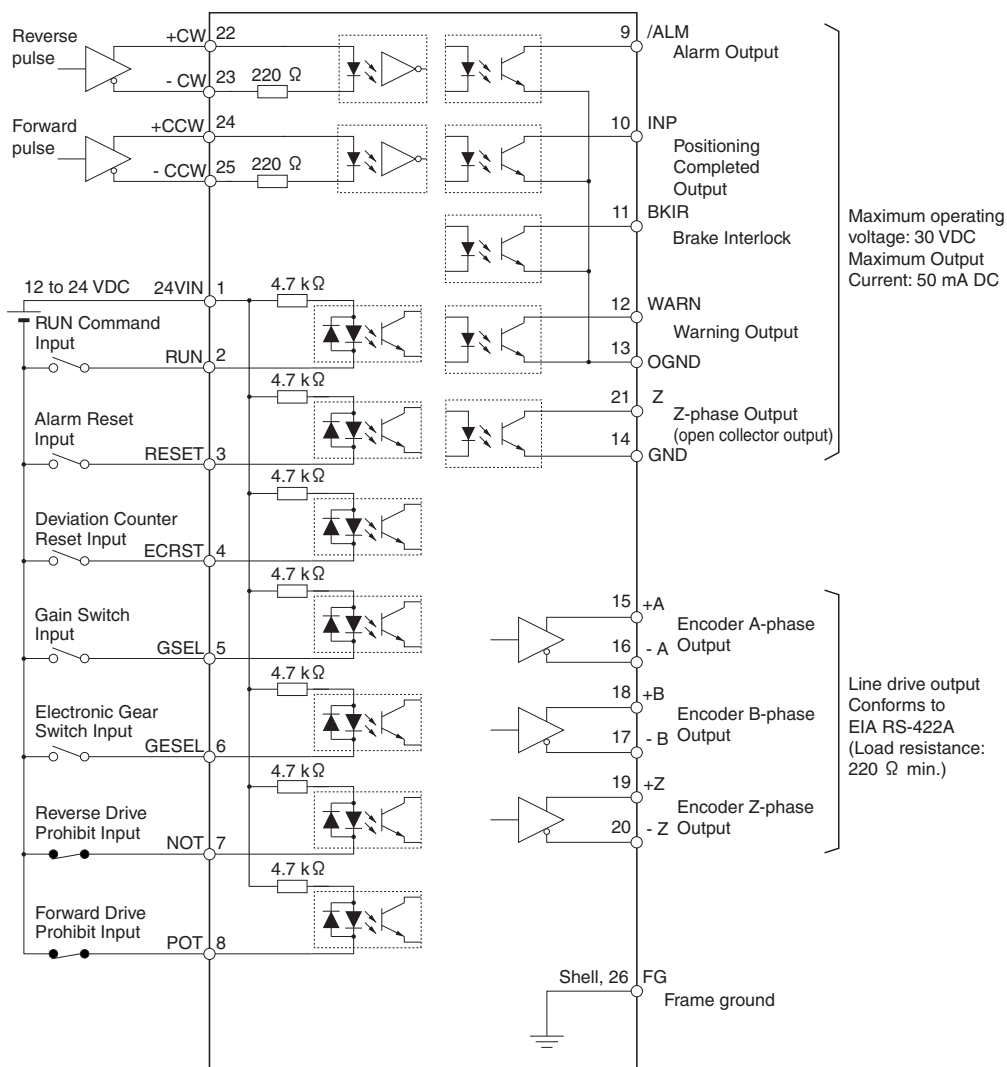

● Control Input Circuits

● Position Command Pulse Inputs

Line Drive Input

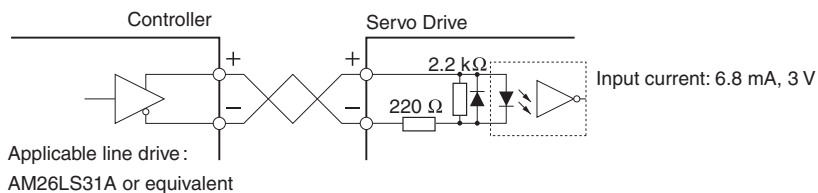

Open-collector Input

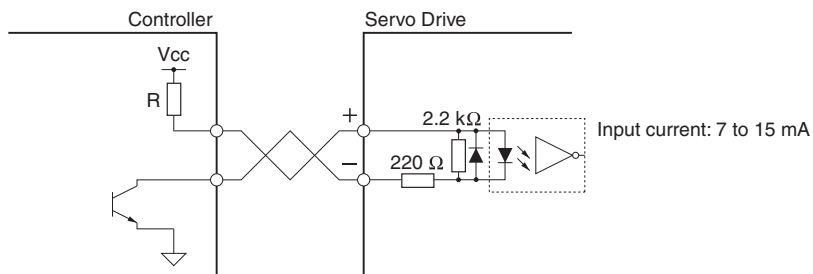

**Note:** Select a value for resistance R so that the input current will be from 7 to 15 mA. Refer to the following table.

Vcc	R
24 V	2 kΩ
12 V	1 kΩ

● Sequence Inputs

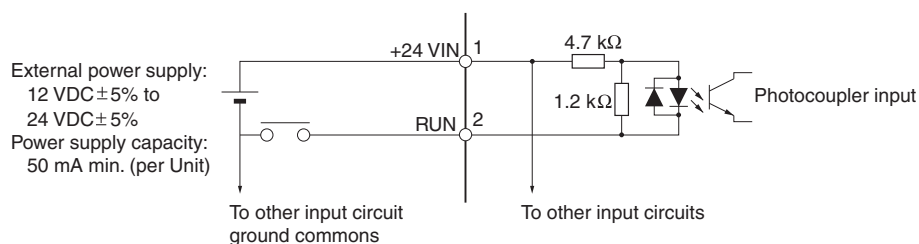

● Control Output Circuits

● Position Feedback Output

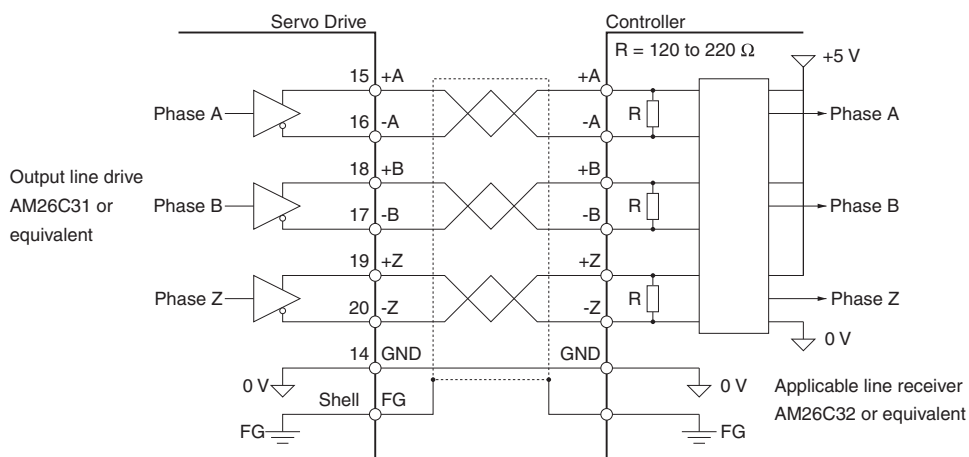

● Sequence and Alarm Outputs

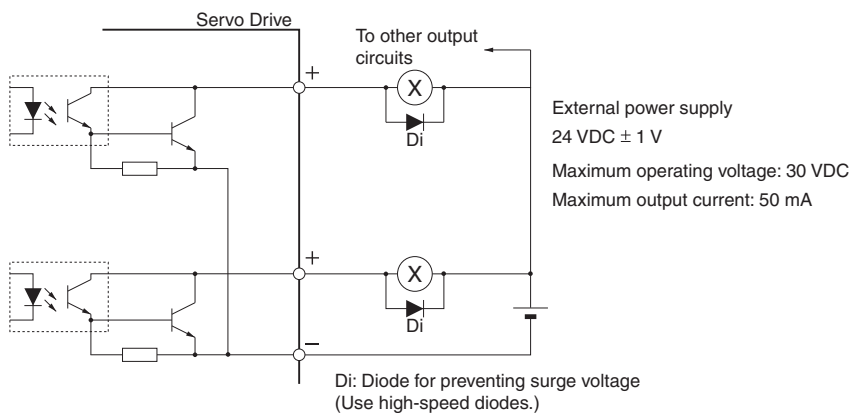

● Phase-Z Output (Open-collector Output)

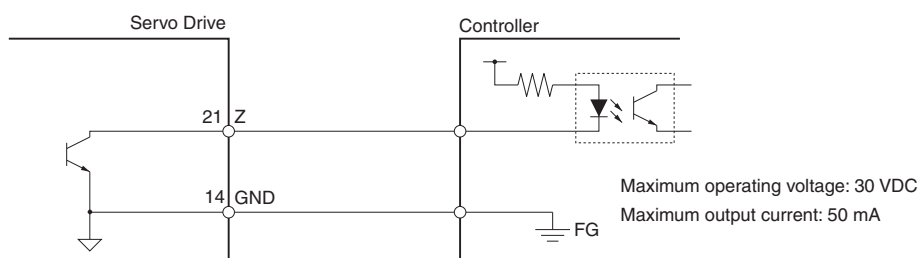

## Nomenclature and Functions

### ■ Serbo Drive Nomenclature

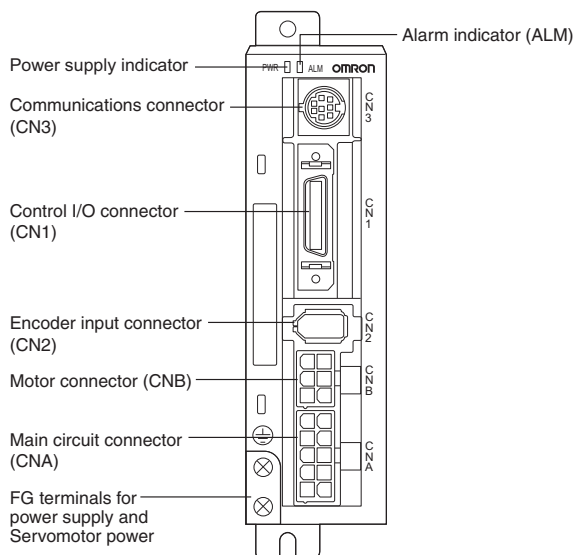

#### ● R7A-CN201P Main Circuit Connector (CNA)

Terminal label	Pin No.	Name
L1	10	Main circuits power supply input
L2	8	
L3	6	
P	5	External Regeneration Resistance Unit connection terminal
B1	3	
FG	1	Frame ground

#### ● R7A-CNB01A Servomotor Connector (CNB) Specifications

Terminal label	Pin No.	Name
U	1	Servomotor connection Terminals
V	4	
W	6	
⊕	3	Frame ground

#### ● Power Supply Indicator (PWR)

Indicator	Status
Lit green	Main power is ON.
Lit orange	Flashes at a 1-second intervals when there is a warning (i.e., overload, excessive regenerative energy, or fan speed error).
Lit red	An alarm has occurred.

#### ● Alarm Indicator (ALM)

This indicator lights when an alarm has occurred.

#### ● CN1 Control Inputs

Pin No.	Signal name	Function
1	+24VIN	DC power supply input for control
2	RUN	RUN Command Input
3	RESET	Alarm Reset Input *1
4	ECRST/VSEL2	Deviation Counter Reset Input or Internally Set Speed Selection 2 Input
5	GSEL/VZERO/TLSEL	Gain Switch Input, Zero Speed Designation Input, or Torque Limit Switch Input
6	GESEL/VSEL1	Electronic Gear Switch Input or Internally Set Speed Selection 1 Input *2
7	NOT	Reverse Drive Prohibit Input
8	POT	Forward Drive Prohibit Input
22	+CW/PULS/FA	Reverse Pulses Input, Feed Pulses Input, or 90° Phase Difference Pulses (Phase A)
23	-CW/PULS/FA	
24	+CCW/SIGN/FB	Forward Pulses, Direction Signal, or 90° Phase Difference Pulses (Phase B)
25	-CCW/SIGN/FB	

- \* 1. Some alarms cannot be cleared using this input.
- \* 2. Do not input command pulses for 10 ms before or after switching the electronic gear.

#### ● CN1 Control Outputs

Pin No.	Signal name	Function
9	/ALM	Alarm Output *1
10	INP/TGON	Positioning Completed Output or Servomotor Rotation Amount Detection Output
11	BKIR	Brake Interlock Output
12	WARN	Warning Output
13	OGND	Output Ground Common
14	GND	Ground Common
15	+A	Encoder Phase-A Output
16	-A	
17	-B	Encoder Phase-B Output
18	+B	
19	+Z	Encoder Phase-Z Output
20	-Z	
21	Z	Phase-Z Output

- \* 1. This is OFF for approximately 2 seconds after turning ON the power.
- Note:** This is OFF for approximately 2 seconds after turning ON the power. An open-collector output interface is used for sequence outputs (maximum operating voltage: 30 VDC; maximum output current: 50 mA).

## ■ R88A-PR02G Parameter Unit Nomenclature

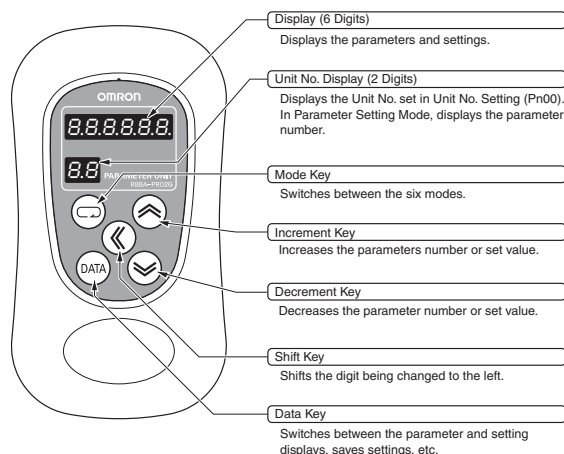

## ● Function Selection Parameters

Parameter name	Explanation
Unit No. Setting	Set the unit number.
Default Display	Set the data to display on the Parameter Unit when the power supply is turned ON.
Control Mode Selection	Set the control mode to be used.
Drive Prohibit Input Selection	You can stop the Servomotor from rotating beyond the device's travel range by connecting limit inputs.
Zero Speed Designation/Speed Command Direction Switch	Set the function of the Zero Speed Designation Input (VZERO) and Torque Limit Switch Input (TLSEL).
Warning Output Selection	Allocate the function of the Warning Output (WARN).

## ● Servo Gain Parameters

Parameter name	Explanation
Position Loop Gain *1	Set to adjust the position loop responsiveness.
Speed Loop Gain *1	Set to adjust the speed loop responsiveness.
Speed Loop Integration Constant *1	Set the speed loop integral time constant.
Speed Feedback Filter Time Constant *1	Set the time constant for the low pass filter through which the signal passes after the speed signal from the encoder signal is converted.
Torque Command Filter Time Constant *1	Set the primary lag filter constant for the torque command section.
Feed-forward Amount *1	Set the position control feed-forward compensation value.
Feed-forward Command Filter *1	Set the position control feed-forward command filter.
Position Loop Gain 2 *1	Set to adjust the position loop responsiveness.
Speed Loop Gain 2 *1	Set to adjust the speed loop responsiveness.
Speed Loop Integration Constant 2 *1	Set the speed loop integral time constant.
Speed Feedback Filter Time Constant 2 *1	Set the time constant for the low pass filter through which the signal passes after the speed signal from the encoder signal is converted.
Torque Command Filter Time Constant 2 *1	Set the primary lag filter constant for the torque command section.
Notch Filter 1 Frequency	Set the notch frequency of the resonance suppression notch filter.
Notch Filter 1 Width	Set the width to one of five levels for the resonance suppression notch filter. Normally, use the default setting.
Inertia Ratio *1	Set the ratio between the mechanical system inertia and the Servomotor rotor inertia.
Realtime Autotuning Mode Selection	Set the operating mode for realtime autotuning.
Realtime Autotuning Machine Rigidity Selection	Set the machine rigidity for executing realtime autotuning to one of 16 levels. The higher the machine rigidity, the greater the setting needs to be. The higher the setting, the higher the responsiveness.
Autotuning Operation Setting	Set the operating pattern for autotuning.
Overrun Limit Setting	Set the possible operating range for the Servomotor. The overwrite limit function is disabled if this parameter is set to 0.
Vibration Frequency	Set the vibration frequency for dampening to suppress vibration at the end of the load.
Vibration Filter Setting	Set vibration filter for dampening to suppress vibration at the end of the load.
Adaptive Filter Table Number *1	Gives the table entry number corresponding to the frequency of the adaptive filter. This parameter is set automatically and cannot be changed if the adaptive filter is enabled (i.e., if the Realtime Autotuning Mode Selection (Pn21) is set to 1 to 3 or 7).
Gain Switching Input Operating Mode Selection	Enable or disable gain switching. If switching is enabled, the setting of the Gain Switch Setting (Pn31) is used as the condition for switching between gain 1 and gain 2.
Gain Switch Setting	Select the condition for switching between gain 1 and gain 2. The Gain Switching Input Operating Mode (Pn30) must be set to 1 (enabled).
Gain Switch Time *1	This parameter is enabled when the Gain Switch Setting (Pn31) is set to 3, or 5 to 10. Set the delay time from the point at which status no longer meets the switching condition selected in Pn31 until returning to gain 1.
Gain Switch Level Setting *1	This parameter is enabled when the Gain Switch Setting (Pn31) is set to 3, 5, 6, 9, or 10. Set the judgment level for switching between gain 1 and gain 2. The unit for the setting depends on the condition set for the Gain Switch Setting (Pn31).
Gain Switch Hysteresis Setting *1	Set the hysteresis width above and below the judgment level set in the Gain Switch 1 Level Setting (Pn33).
Position Loop Gain Switching Time *1	When switching between gain 1 and gain 2 is enabled, set the switching time to use for the position loop gain to switch the gain stepwise.

\* 1. These parameters are automatically changed by executing realtime autotuning. To set them manually, set the Realtime Autotuning Mode Selection (Pn21) to 0.

● Position Control Parameters

Parameter name	Explanation
Command Pulse Input Setting	The command pulses can be multiplied by a factor of 2 or 4 when 90° phase differential signal inputs is selected as the input format for the command pulses in the Command Pulse Mode (Pn42).
Command Pulse Rotation Direction Switch	Set the Servomotor rotation direction for the command pulse input.
Command Pulse Mode	Set the form of the pulse inputs sent as the command to the Servo Drive from a position controller.
Encoder Divider Rate Setting	Set the number of encoder pulses to be output from the Servo Drive for each rotation. The setting can be made from 1 to 16,384 pulses/rotation, but the setting will not be valid if it exceeds 2,500 pulses/rotation.
Encoder Output Direction Switch	Set to reverse the logic of encoder pulses output from the Servo Drive.
Electronic Gear Ratio Numerator 1	Set the pulse rate for command pulses and Servomotor travel distance.
Electronic Gear Ratio Numerator 2	Electronic Gear Ratio Numerator 1 (Pn46) or $\times 2$ Electronic Gear Ratio Numerator Exponent (Pn4A) Electronic Gear Ratio Numerator 2 (Pn47) Electronic Gear Ratio Denominator (Pn4B)
Electronic Gear Ratio Numerator Exponent	Set the pulse rate for command pulses and Servomotor travel distance.
Electronic Gear Ratio Numerator Exponent	Electronic Gear Ratio Numerator 1 (Pn46) or $\times 2$ Electronic Gear Ratio Numerator Exponent (Pn4A) Electronic Gear Ratio Numerator 2 (Pn47) Electronic Gear Ratio Denominator (Pn4B)
Position Command Filter Time Constant Setting	Set the time constant for the primary lag filter for the command pulse input. If the parameter is set to 0, the filter will not function. The larger the setting, the larger the time constant.
Smoothing Filter Setting	Select the FIR filter time constant used for the command pulse input. The higher the setting, the smoother the command pulses.

● Internally Set Speed Control Parameters

Parameter name	Explanation
No. 1 Internal Speed Setting	Set the No. 1 internal speed.
No. 2 Internal Speed Setting	Set the No. 2 internal speed.
No. 3 Internal Speed Setting	Set the No. 3 internal speed.
No. 4 Internal Speed Setting	Set the No. 4 internal speed.
Jog Speed	Set the speed for jogging.
Soft Start Acceleration Time	Set the acceleration time for internal speed control. Set the time (setting $\times$ 2 ms) until 1,000 r/min is reached.
Soft Start Deceleration Time	Set the deceleration time for internal speed control. Set the time (setting $\times$ 2 ms) until operation stops from 1000 r/min.
Torque Limit	Set the limit to the Servomotor's maximum torque.

● Sequence Parameters

Parameter name	Explanation
Positioning Completion Range	Set the range for the Positioning Completed Output (INP).
Zero Speed Detection	Set the speed for the Warning Output for zero speed detection.
Rotation Speed for Motor Rotation Detection	Set the speed for the Servomotor Rotation Amount Detection Output (TGON) for Internally Set Speed Control.
Deviation Counter Overflow Level	Set the detection level for the Deviation Counter Overflow Alarm. The alarm level will be the setting times 256 pulses.
Deviation Counter Overflow Alarm Disabled	Enable or disable the Deviation Counter Overflow Alarm.
Stop Selection for Drive Prohibition Input	Set the operation used to decelerate to a stop after the Forward Drive Prohibit Input (POT) or Reverse Drive Prohibit Input (NOT) has been received.
Stop Selection for Alarm Generation	Set the operation to use during deceleration and after stopping when an error occurs for any protective function of the Servo Drive. The deviation counter will be cleared when an alarm occurs.
Stop Selection with Servo OFF	Set the operation to use during deceleration and after stopping and set the deviation counter status when the RUN Command Input (RUN) is turned OFF.
Brake Timing when Stopped	Set the brake timing when stopped. When the Servomotor is stopped and the RUN Command Input (RUN) is turned OFF, the Brake Interlock Output (BKIR) will turn OFF, and the Servomotor will turn OFF after waiting for the time period set for this parameter (i.e., setting $\times$ 2 ms).
Brake Timing during Operation	Set the brake timing during operation. When the Servomotor is operating and the RUN Command Input (RUN) is turned OFF, the Servomotor will decelerate to reduce speed, and the Brake Interlock Output (BKIR) will turn OFF after a set time (i.e., setting $\times$ 2 ms) has elapsed. BKIR will also turn OFF if the speed drops to 30 r/min or lower before the set time.
Regeneration Resistor Selection	Set this parameter to 1 or 2 if an external generation resistor is mounted.
Overspeed Detection Level Setting	Set the No. 1 overspeed detection level if torque limit switching is enabled by setting the Zero-speed Designation/Torque Limit Switch (Pn06).
No. 2 Torque Limit	Set the No. 2 torque limit if torque limit switching is enabled by setting the Zero-speed Designation/Torque Limit Switch (Pn06).
No. 2 Deviation Counter Overflow Level	Set the No. 2 deviation counter overflow level if torque limit switching is enabled by setting the Zero-speed Designation/Torque Limit Switch (Pn06).
No. 2 Overspeed Detection Level Setting	Set the No. 2 overspeed detection level if torque limit switching is enabled by setting the Zero-speed Designation/Torque Limit Switch (Pn06).

## Dimensions

### ● Servo Drives

#### • 50 W/100 W/200 W

R7D-BPA5L

R7D-BP01L

R7D-BP01H

R7D-BP02H

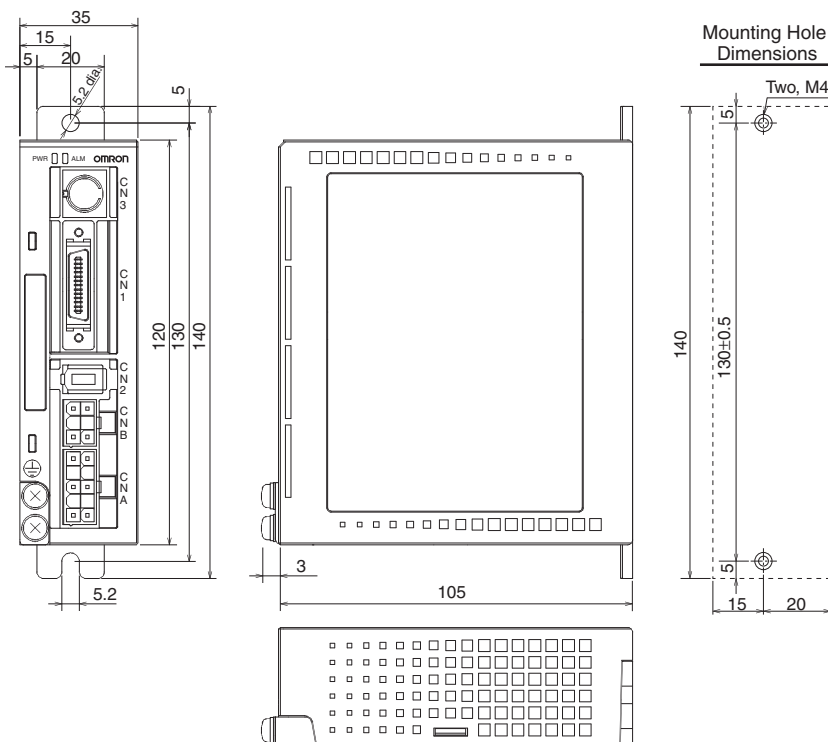

#### • 200 W/400 W

R7D-BP02L

R7D-BP02HH

R7D-BP04H

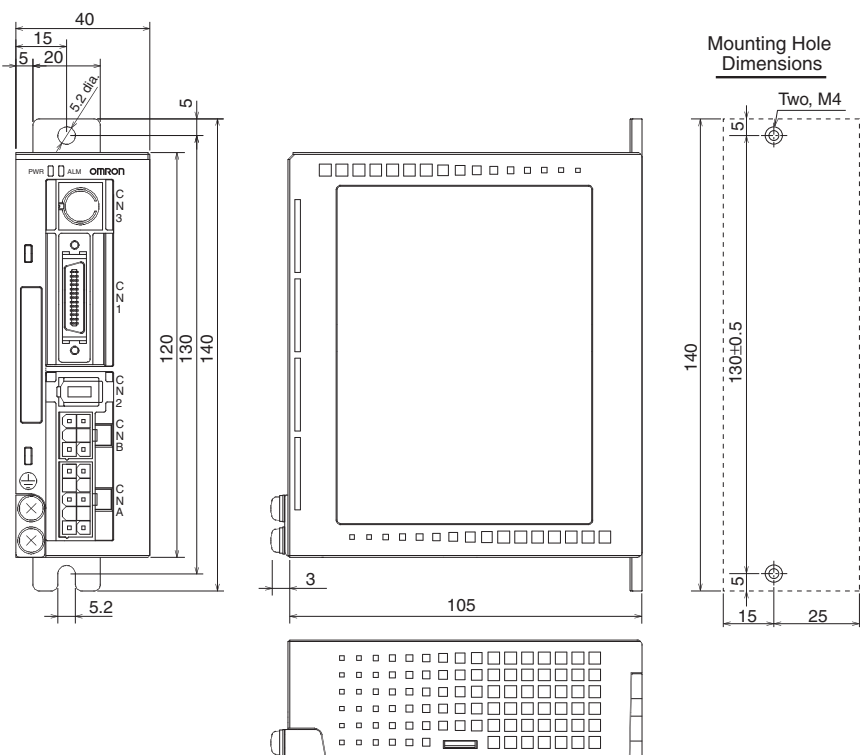

● Servomotors

3,000-r/min Cylindrical Servomotors

• 50 W/100 W

**Without brake** R88M-G05030H (-S2)  
R88M-G10030L (-S2)  
R88M-G10030H (-S2)

**With brake** R88M-G05030H (-S2)  
R88M-G10030L (-S2)  
R88M-G10030H (-S2)

Model	LL	LN
R88M-G05030H	72	26.5
R88M-G05030H-B <sup>*1</sup>	102	26.5
R88M-G10030□ <sup>*2</sup>	92	46.5
R88M-G10030□-B <sup>*1,*2</sup>	122	46.5

\* 1. This is the model number for the Servomotor with a brake.  
\* 2. Put "L" or "H" in the place indicated by the box.

**Note:** The standard models have a straight shaft. To order a Servomotor with a straight shaft with a key, add "S2" to the end of the model number.

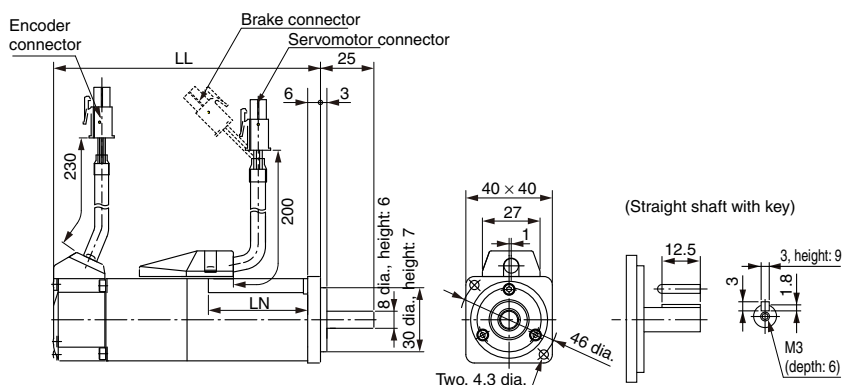

• 200 W/400 W

**Without brake** R88M-G20030L (-S2)  
R88M-G20030H (-S2)  
R88M-G40030H (-S2)

**With brake** R88M-G20030L-B (S2)  
R88M-G20030H-B (S2)  
R88M-G40030H-B (S2)

Model	LL	S	Dimensions for models with key and tap <sup>*3</sup>						
			QK	b	h	t1	M	L	
R88M-G20030□ <sup>*1</sup>	79	11	18	4h9	4	2.5	M4	8	
R88M-G20030□-B <sup>*1,*2</sup>	115.5	11	18	4h9	4	2.5	M4	8	
R88M-G40030H	98.5	14	22.5	5h9	5	3	M5	10	
R88M-G40030H-B <sup>*2</sup>	135	14	22.5	5h9	5	3	M5	10	

\* 1. Put "L" or "H" in the place indicated by the box.  
\* 2. This is the model number for the Servomotor with a brake.  
\* 3. To order a Servomotor with a straight shaft with a key, add "S2" to the end of the model number.

**Note:** The standard models have a straight shaft.

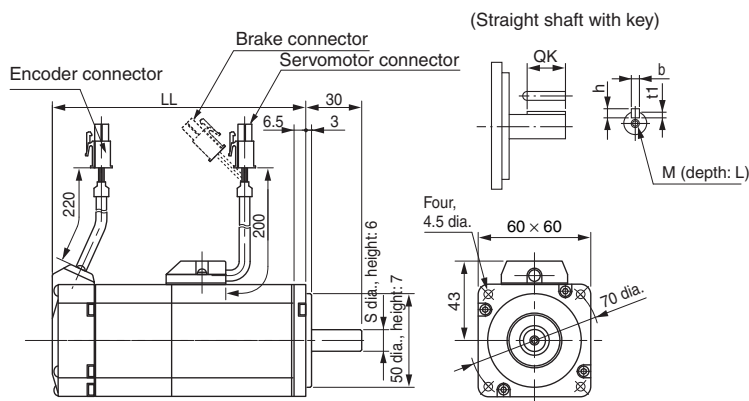

3,000-r/min Flat Servomotors

• 100 W/200 W/400 W

**Without brake** R88M-GP10030L (-S2)  
 R88M-GP10030H (-S2)  
 R88M-GP20030L (-S2)  
 R88M-GP20030H (-S2)  
 R88M-GP40030H (-S2)

**With brake** R88M-GP10030L-B (S2)  
 R88M-GP10030H-B (S2)  
 R88M-GP20030L-B (S2)  
 R88M-GP20030H-B (S2)  
 R88M-GP40030H-B (S2)

Model	LL	LR	S	D1	D2	C	F	G	KL1	Z	Dimensions for models with key and tap <sup>3</sup>					
											QK	b	h	t1	M	L
R88M-GP10030□ <sup>1</sup>	60	25	8	70	50	60	3	7	43	4.5	12.5	3h9	3	1.8	M3	6
R88M-GP10030□-B <sup>1,2</sup>	84	25	8	70	50	60	3	7	43	4.5	12.5	3h9	3	1.8	M3	6
R88M-GP20030□ <sup>1</sup>	67	30	11	90	70	80	5	8	53	5.5	18	4h9	4	2.5	M4	8
R88M-GP20030□-B <sup>1,2</sup>	99.5	30	11	90	70	80	5	8	53	5.5	18	4h9	4	2.5	M4	8
R88M-GP40030H	82	30	14	90	70	80	5	8	53	5.5	22.5	5h9	5	3	M5	10
R88M-GP40030H-B <sup>2</sup>	114.5	30	14	90	70	80	5	8	53	5.5	22.5	5h9	5	3	M5	10

- \* 1. Put "L" or "H" in the place indicated by the box.
- \* 2. This is the model number for the Servomotor with a brake.
- \* 3. To order a Servomotor with a straight shaft with a key, add "S2" to the end of the model number.

**Note:** The standard models have a straight shaft.

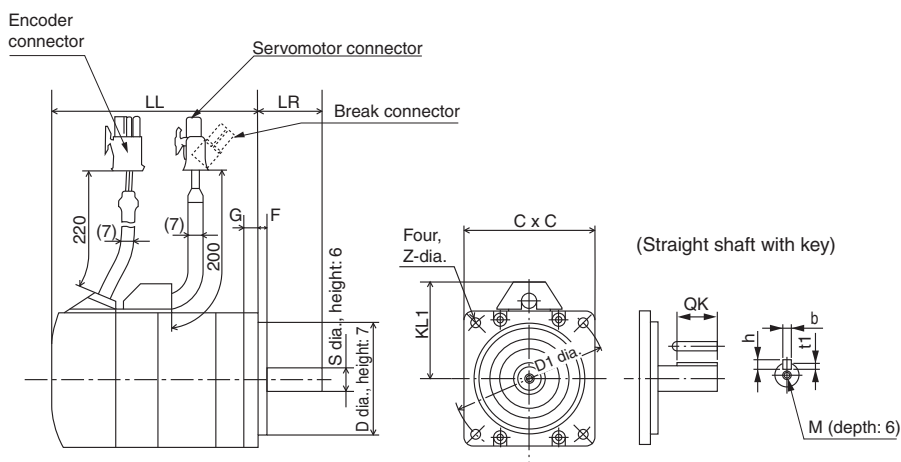

● Decelerators

Decelerators for Cylindrical Servomotors

Backlash: 3 Arcminutes Max.

Model			Dimensions (mm)												
			LM	LR	C1	C2	D1	D2	D3	D4	D5	E	F1	F2	G
50 W	1/5	R88G-HPG11A05100B	39.5	42	40	40 × 40	46	46	40.0	39.5	29	27	2.2	15	5
	1/9	R88G-HPG11A09050B	39.5	42	40	40 × 40	46	46	40.0	39.5	29	27	2.2	15	5
	1/21	R88G-HPG14A21100B	64.0	58	60	60 × 60	70	46	56.0	55.5	40	37	2.5	21	8
	1/33	R88G-HPG14A33050B	64.0	58	60	60 × 60	70	46	56.0	55.5	40	37	2.5	21	8
	1/45	R88G-HPG14A45050B	64.0	58	60	60 × 60	70	46	56.0	55.5	40	37	2.5	21	8
100 W	1/5	R88G-HPG11A05100B	39.5	42	40	40 × 40	46	46	40.0	39.5	29	27	2.2	15	5
	1/11	R88G-HPG14A11100B	64.0	58	60	60 × 60	70	46	56.0	55.5	40	37	2.5	21	8
	1/21	R88G-HPG14A21100B	64.0	58	60	60 × 60	70	46	56.0	55.5	40	37	2.5	21	8
	1/33	R88G-HPG20A33100B	66.5	80	90	55 dia.	105	46	85.0	84.0	59	53	7.5	27	10
	1/45	R88G-HPG20A45100B	66.5	80	90	55 dia.	105	46	85.0	84.0	59	53	7.5	27	10
200 W	1/5	R88G-HPG14A05200B	64.0	58	60	60 × 60	70	70	56.0	55.5	40	37	2.5	21	8
	1/11	R88G-HPG14A11200B	64.0	58	60	60 × 60	70	70	56.0	55.5	40	37	2.5	21	8
	1/21	R88G-HPG20A21200B	71.0	80	90	89 dia.	105	70	85.0	84.0	59	53	7.5	27	10
	1/33	R88G-HPG20A33200B	71.0	80	90	89 dia.	105	70	85.0	84.0	59	53	7.5	27	10
	1/45	R88G-HPG20A45200B	71.0	80	90	89 dia.	105	70	85.0	84.0	59	53	7.5	27	10
400 W	1/5	R88G-HPG14A05400B	64.0	58	60	60 × 60	70	70	56.0	55.5	40	37	2.5	21	8
	1/11	R88G-HPG20A11400B	71.0	80	90	89 dia.	105	70	85.0	84.0	59	53	7.5	27	10
	1/21	R88G-HPG20A21400B	71.0	80	90	89 dia.	105	70	85.0	84.0	59	53	7.5	27	10
	1/33	R88G-HPG32A33400B	104.0	133	120	122 dia.	135	70	115.0	114.0	84	98	12.5	35	13
	1/45	R88G-HPG32A45400B	104.0	133	120	122 dia.	135	70	115.0	114.0	84	98	12.5	35	13

**Note:** The standard models have a straight shaft. To order a Decelerator with a straight shaft with a key, add "J" to the end of the model number, in the place indicated by the box.

\* 1. This is the set bolt.

Outline Drawings

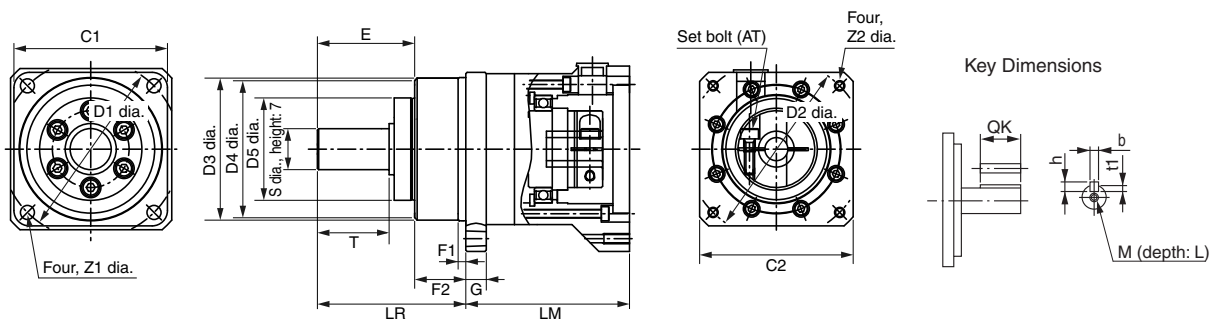

	Dimensions (mm)						Key dimensions (mm)					Weight (kg)	Model		
	S	T	Z1	Z2	AT <sup>*1</sup>	QK	b	h	t1	M	L				
	8	20	3.4	M4	M3	15	3	3	1.8	M3	6	0.29	R88G-HPG11A05100B	1/5	50 W
	8	20	3.4	M4	M3	15	3	3	1.8	M3	6	0.29	R88G-HPG11A09050B	1/9	
	16	28	5.5	M4	M3	25	5	5	3	M4	8	1.04	R88G-HPG14A21100B	1/21	
	16	28	5.5	M4	M3	25	5	5	3	M4	8	1.04	R88G-HPG14A33050B	1/33	
	16	28	5.5	M4	M3	25	5	5	3	M4	8	1.04	R88G-HPG14A45050B	1/45	
	8	20	3.4	M4	M3	15	3	3	1.8	M3	6	0.29	R88G-HPG11A05100B	1/5	100 W
	16	28	5.5	M4	M3	25	5	5	3	M4	8	1.04	R88G-HPG14A11100B	1/11	
	16	28	5.5	M4	M3	25	5	5	3	M4	8	1.04	R88G-HPG14A21100B	1/21	
	25	42	9.0	M4	M4	36	8	7	4.0	M6	12	2.4	R88G-HPG20A33100B	1/33	
	25	42	9.0	M4	M4	36	8	7	4.0	M6	12	2.4	R88G-HPG20A45100B	1/45	
	16	28	5.5	M4	M3	25	5	5	3	M4	8	1.02	R88G-HPG14A05200B	1/5	200 W
	16	28	5.5	M4	M3	25	5	5	3	M4	8	1.09	R88G-HPG14A11200B	1/11	
	25	42	9.0	M4	M4	36	8	7	4.0	M6	12	2.9	R88G-HPG20A21200B	1/21	
	25	42	9.0	M4	M4	36	8	7	4.0	M6	12	2.9	R88G-HPG20A33200B	1/33	
	25	42	9.0	M4	M4	36	8	7	4.0	M6	12	2.9	R88G-HPG20A45200B	1/45	
	16	28	5.5	M4	M3	25	5	5	3	M4	8	1.09	R88G-HPG14A05400B	1/5	400 W
	25	42	9.0	M4	M4	36	8	7	4.0	M6	12	2.9	R88G-HPG20A11400B	1/11	
	25	42	9.0	M4	M4	36	8	7	4.0	M6	12	2.9	R88G-HPG20A21400B	1/21	
	40	82	11.0	M4	M4	70	12	8	5.0	M10	20	7.5	R88G-HPG32A33400B	1/33	
	40	82	11.0	M4	M4	70	12	8	5.0	M10	20	7.5	R88G-HPG32A45400B	1/45	

Decelerators for Flat Servomotors

Backlash: 3 Arcminutes Max.

Model			Dimensions (mm)												
			LM	LR	C1	C2	D1	D2	D3	D4	D5	E	F1	F2	G
100 W	1/5	R88G-HPG11A05100PB	39.5	42	40	60 × 60	46	70	40.0	39.5	29	27	2.2	15	5
	1/11	R88G-HPG14A11100PB	64.0	58	60	60 × 60	70	70	56.0	55.5	40	37	2.5	21	8
	1/21	R88G-HPG14A21100PB	64.0	58	60	60 × 60	70	70	56.0	55.5	40	37	2.5	21	8
	1/33	R88G-HPG20A33100PB	71.0	80	90	89 dia.	105	70	85.0	84.0	59	53	7.5	27	10
	1/45	R88G-HPG20A45100PB	71.0	80	90	89 dia.	105	70	85.0	84.0	59	53	7.5	27	10
200 W	1/5	R88G-HPG14A05200PB	65.0	58	60	80 × 80	70	90	56.0	55.5	40	37	2.5	21	8
	1/11	R88G-HPG20A11200PB	78.0	80	90	80 × 80	105	90	85.0	84.0	59	53	7.5	27	10
	1/21	R88G-HPG20A21200PB	78.0	80	90	80 × 80	105	90	85.0	84.0	59	53	7.5	27	10
	1/33	R88G-HPG20A33200PB	78.0	80	90	80 × 80	105	90	85.0	84.0	59	53	7.5	27	10
	1/45	R88G-HPG20A45200PB	78.0	80	90	80 × 80	105	90	85.0	84.0	59	53	7.5	27	10
400 W	1/5	R88G-HPG20A05400PB	78.0	80	90	80 × 80	105	90	85.0	84.0	59	53	7.5	27	10
	1/11	R88G-HPG20A11400PB	78.0	80	90	80 × 80	105	90	85.0	84.0	59	53	7.5	27	10
	1/21	R88G-HPG20A21400PB	78.0	80	90	80 × 80	105	90	85.0	84.0	59	53	7.5	27	10
	1/33	R88G-HPG32A33400PB	104.0	133	120	122 dia.	135	90	115.0	114.0	84	98	12.5	35	13
	1/45	R88G-HPG32A45400PB	104.0	133	120	122 dia.	135	90	115.0	114.0	84	98	12.5	35	13

Note: The standard models have a straight shaft. To order a Decelerator with a straight shaft with a key, add "J" to the end of the model number, in the place indicated by the box.

\* 1. This is the set bolt.

Outline Drawings

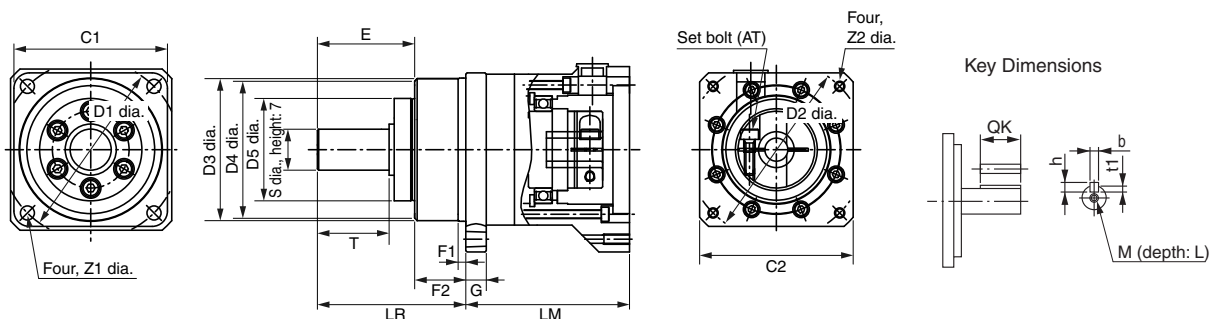

	Dimensions (mm)						Key dimensions (mm)					Weight (kg)	Model		
	S	T	Z1	Z2	AT <sup>1</sup>	QK	b	h	t1	M	L				
	8	20	3.4	M4	M3	15	3	3	1.8	M3	6	0.34	R88G-HPG11A05100PB	1/5	100 W
	16	28	5.5	M4	M3	25	5	5	3.0	M4	8	1.04	R88G-HPG14A11100PB	1/11	
	16	28	5.5	M4	M3	25	5	5	3.0	M4	8	1.04	R88G-HPG14A21100PB	1/21	
	25	42	9.0	M4	M3	36	8	7	4.0	M6	12	2.9	R88G-HPG20A33100PB	1/33	
	25	42	9.0	M4	M3	36	8	7	4.0	M6	12	2.9	R88G-HPG20A45100PB	1/45	
	16	28	5.5	M4	M4	25	5	5	3.0	M4	8	0.99	R88G-HPG14A05200PB	1/5	200 W
	25	42	9.0	M5	M4	36	8	7	4.0	M6	12	3.1	R88G-HPG20A11200PB	1/11	
	25	42	9.0	M5	M4	36	8	7	4.0	M6	12	3.1	R88G-HPG20A21200PB	1/21	
	25	42	9.0	M5	M4	36	8	7	4.0	M6	12	3.1	R88G-HPG20A33200PB	1/33	
	25	42	9.0	M5	M4	36	8	7	4.0	M6	12	3.1	R88G-HPG20A45200PB	1/45	
	25	42	9.0	M5	M4	36	8	7	4.0	M6	12	3.1	R88G-HPG20A05400PB	1/5	400 W
	25	42	9.0	M5	M4	36	8	7	4.0	M6	12	3.1	R88G-HPG20A11400PB	1/11	
	25	42	9.0	M5	M4	36	8	7	4.0	M6	12	3.1	R88G-HPG20A21400PB	1/21	
	40	82	11.0	M5	M6	70	12	8	5.0	M10	20	7.8	R88G-HPG32A33400PB	1/33	
	40	82	11.0	M5	M6	70	12	8	5.0	M10	20	7.8	R88G-HPG32A45400PB	1/45	

Decelerators for Cylindrical Servomotors

Backlash: 15 Arcminutes Max.

Model (R88G-)			Dimensions (mm)																	Key dimensions (mm)				Weight (kg)
			LM	LR	C1	C2	D1	D2	D3	D4	E3	F	G	S	T	Z1	Z2	AT *1	L	QK	b	h	t1	
50 W	1/5	VRSF05B100CJ	67.5	32	52	40	46	60	50	45	10	3	6	12	20	M4	M5	M3	12	16	4	4	2.5	0.55
	1/9	VRSF09B100CJ	67.5	32	52	40	46	60	50	45	10	3	6	12	20	M4	M5	M3	12	16	4	4	2.5	0.55
	1/15	VRSF15B100CJ	78.0	32	52	40	46	60	50	45	10	3	6	12	20	M4	M5	M3	12	16	4	4	2.5	0.70
	1/25	VRSF25B100CJ	78.0	32	52	40	46	60	50	45	10	3	6	12	20	M4	M5	M3	12	16	4	4	2.5	0.70
100 W	1/5	VRSF05B100CJ	67.5	32	52	40	46	60	50	45	10	3	6	12	20	M4	M5	M3	12	16	4	4	2.5	0.55
	1/9	VRSF09B100CJ	67.5	32	52	40	46	60	50	45	10	3	6	12	20	M4	M5	M3	12	16	4	4	2.5	0.55
	1/15	VRSF15B100CJ	78.0	32	52	40	46	60	50	45	10	3	6	12	20	M4	M5	M3	12	16	4	4	2.5	0.70
	1/25	VRSF25B100CJ	78.0	32	52	40	46	60	50	45	10	3	6	12	20	M4	M5	M3	12	16	4	4	2.5	0.70
200 W	1/5	VRSF05B200CJ	72.5	32	52	60	70	60	50	45	10	3	10	12	20	M4	M5	M4	12	16	4	4	2.5	0.72
	1/9	VRSF09C200CJ	89.5	50	78	60	70	90	70	62	17	3	8	19	30	M4	M6	M4	20	22	6	6	3.5	1.70
	1/15	VRSF15C200CJ	100.0	50	78	60	70	90	70	62	17	3	8	19	30	M4	M6	M4	20	22	6	6	3.5	2.10
	1/25	VRSF25C200CJ	100.0	50	78	60	70	90	70	62	17	3	8	19	30	M4	M6	M4	20	22	6	6	3.5	2.10
400 W	1/5	VRSF05C400CJ	89.5	50	78	60	70	90	70	62	17	3	8	19	30	M4	M6	M4	20	22	6	6	3.5	1.70
	1/9	VRSF09C400CJ	89.5	50	78	60	70	90	70	62	17	3	8	19	30	M4	M6	M4	20	22	6	6	3.5	1.70
	1/15	VRSF15C400CJ	100.0	50	78	60	70	90	70	62	17	3	8	19	30	M4	M6	M4	20	22	6	6	3.5	2.10
	1/25	VRSF25C400CJ	100.0	50	78	60	70	90	70	62	17	3	8	19	30	M4	M6	M4	20	22	6	6	3.5	2.10

\* 1. This is the set bolt.

Note: The standard models have a straight shaft with a key.

Outline Drawings

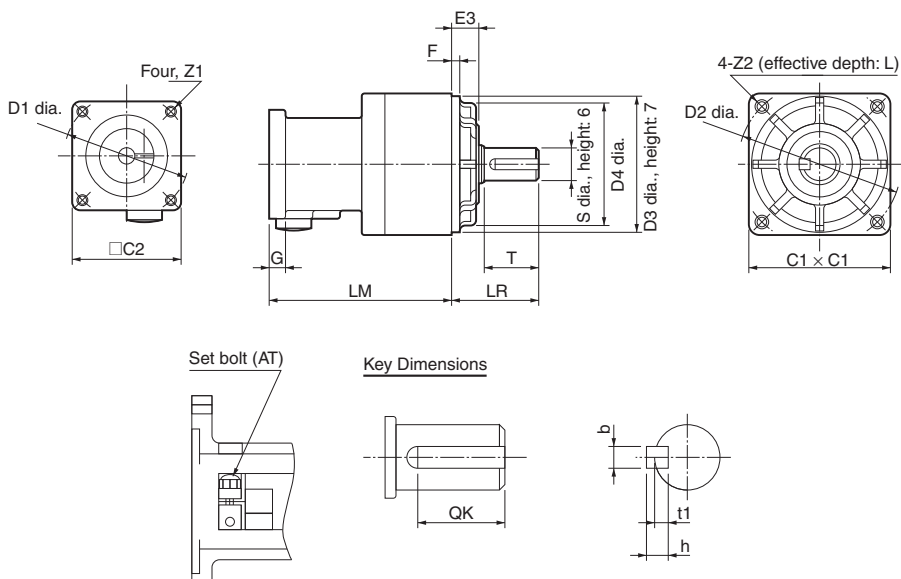

Decelerators for Flat Servomotors

**Backlash: 15 Arcminutes Max.**

Model (R88G-)		Dimensions (mm)											Dimensions (mm)					Key dimensions (mm)				Weight (kg)		
		LM	LR	C1	C2	D1	D2	D3	D4	E3	F	G	S	T	Z1	Z2	AT *1	L	QK	b	h		t1	
100 W	1/5	VRSF05B100PCJ	67.5	32	52	60	70	60	50	45	10	3	8	12	20	M4	M5	M3	12	16	4	4	2.5	0.72
	1/9	VRSF09B100PCJ	67.5	32	52	60	70	60	50	45	10	3	8	12	20	M4	M5	M3	12	16	4	4	2.5	0.72
	1/15	VRSF15B100PCJ	78.0	32	52	60	70	60	50	45	10	3	8	12	20	M4	M5	M3	12	16	4	4	2.5	0.87
	1/25	VRSF25B100PCJ	78.0	32	52	60	70	60	50	45	10	3	8	12	20	M4	M5	M3	12	16	4	4	2.5	0.87
200 W	1/5	VRSF05B200PCJ	72.5	32	52	80	90	60	50	45	10	3	12	12	20	M5	M5	M4	12	16	4	4	2.5	0.85
	1/9	VRSF09C200PCJ	89.5	50	78	80	90	90	70	62	17	3	12	19	30	M5	M6	M4	20	22	6	6	3.5	1.80
	1/15	VRSF15C200PCJ	100.0	50	78	80	90	90	70	62	17	3	12	19	30	M5	M6	M4	20	22	6	6	3.5	2.20
400 W	1/25	VRSF25C200PCJ	100.0	50	78	80	90	90	70	62	17	3	12	19	30	M5	M6	M4	20	22	6	6	3.5	2.20
	1/5	VRSF05C400PCJ	89.5	50	78	80	90	90	70	62	17	3	12	19	30	M5	M6	M4	20	22	6	6	3.5	1.80
	1/9	VRSF09C400PCJ	89.5	50	78	80	90	90	70	62	17	3	12	19	30	M5	M6	M4	20	22	6	6	3.5	1.80
	1/15	VRSF15C400PCJ	100.0	50	78	80	90	90	70	62	17	3	12	19	30	M5	M6	M4	20	22	6	6	3.5	2.20
	1/25	VRSF25C400PCJ	100.0	50	78	80	90	90	70	62	17	3	12	19	30	M5	M6	M4	20	22	6	6	3.5	2.20

\* 1. This is the set bolt.

**Note:** The standard models have a straight shaft with a key.

**Outline Drawings**

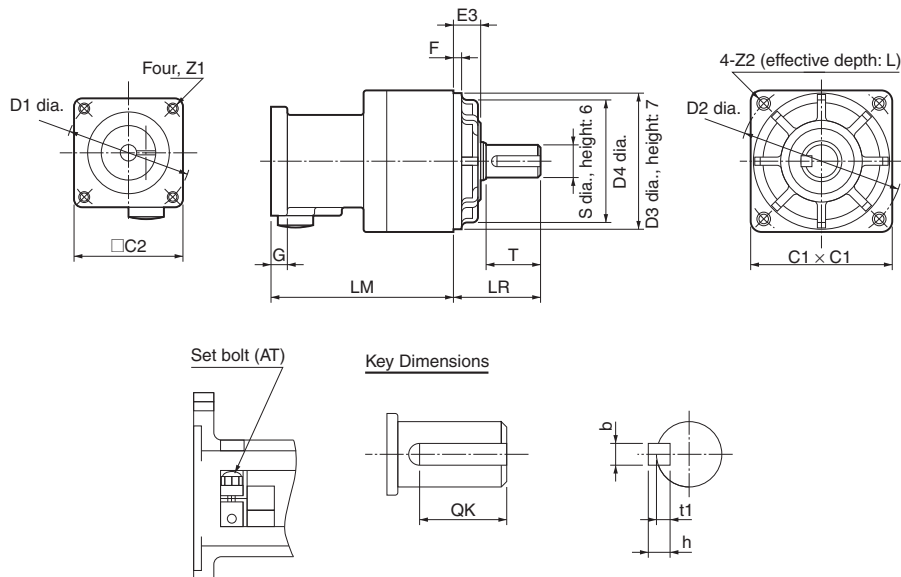

● Parameter Unit

**R88A-PR02G**

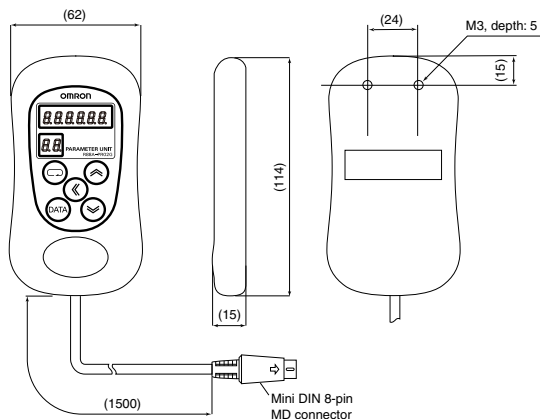

● DIN Rail Mounting Unit

**R7A-DIN01B**

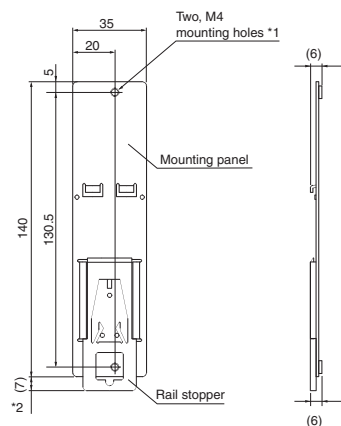

- \* 1. Two mounting screws (M4, length: 8) are included.
- \* 2. When the rail stopper is extended, this dimension becomes 10 mm.

● External Regeneration Resistor

**R88A-RR22047S**

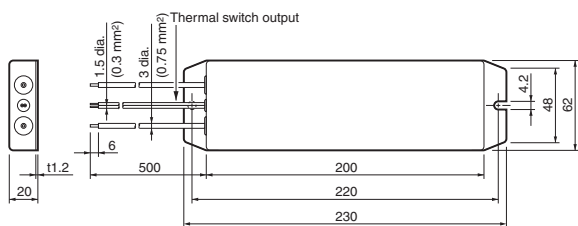

**R88A-RR08050S/RR080100S**

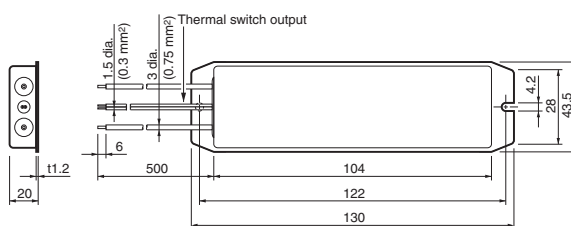

● Reactor

**3G3AX-DL2002**

**3G3AX-DL2004**

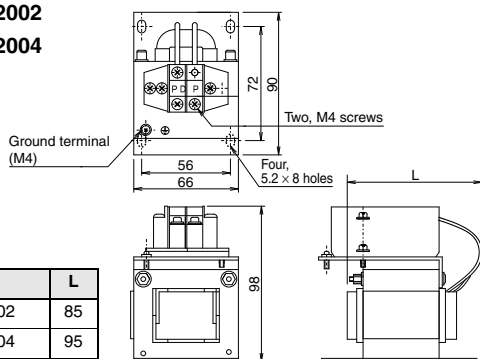

Model	L
3G3AX-DL2002	85
3G3AX-DL2004	95

**3G3AX-DL2007**

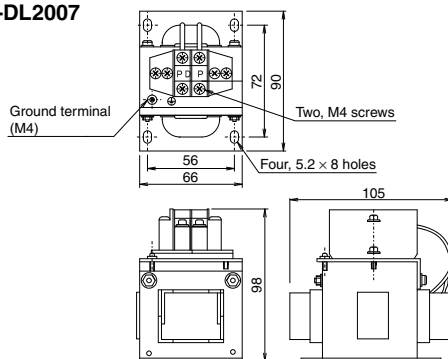

**3G3AX-AL2025**

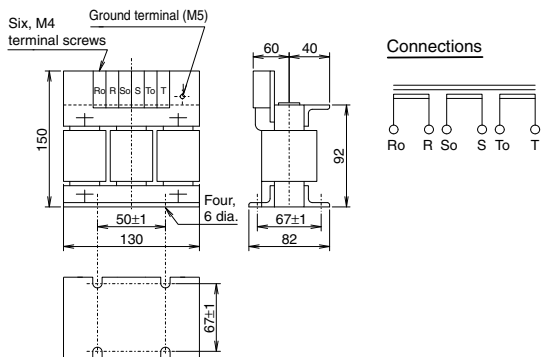

## Read and Understand this Catalog

Please read and understand this catalog before purchasing the product. Please consult your OMRON representative if you have any questions or comments.

## Warranty and Limitations of Liability

### WARRANTY

OMRON's exclusive warranty is that the products are free from defects in materials and workmanship for a period of one year (or other period if specified) from date of sale by OMRON.

OMRON MAKES NO WARRANTY OR REPRESENTATION, EXPRESS OR IMPLIED, REGARDING NON-INFRINGEMENT, MERCHANTABILITY, OR FITNESS FOR PARTICULAR PURPOSE OF THE PRODUCTS. ANY BUYER OR USER ACKNOWLEDGES THAT THE BUYER OR USER ALONE HAS DETERMINED THAT THE PRODUCTS WILL SUITABLY MEET THE REQUIREMENTS OF THEIR INTENDED USE. OMRON DISCLAIMS ALL OTHER WARRANTIES, EXPRESS OR IMPLIED.

### LIMITATIONS OF LIABILITY

OMRON SHALL NOT BE RESPONSIBLE FOR SPECIAL, INDIRECT, OR CONSEQUENTIAL DAMAGES, LOSS OF PROFITS OR COMMERCIAL LOSS IN ANY WAY CONNECTED WITH THE PRODUCTS, WHETHER SUCH CLAIM IS BASED ON CONTRACT, WARRANTY, NEGLIGENCE, OR STRICT LIABILITY.

In no event shall the responsibility of OMRON for any act exceed the individual price of the product on which liability is asserted.

IN NO EVENT SHALL OMRON BE RESPONSIBLE FOR WARRANTY, REPAIR, OR OTHER CLAIMS REGARDING THE PRODUCTS UNLESS OMRON'S ANALYSIS CONFIRMS THAT THE PRODUCTS WERE PROPERLY HANDLED, STORED, INSTALLED, AND MAINTAINED AND NOT SUBJECT TO CONTAMINATION, ABUSE, MISUSE, OR INAPPROPRIATE MODIFICATION OR REPAIR.

## Application Considerations

### SUITABILITY FOR USE

OMRON shall not be responsible for conformity with any standards, codes, or regulations that apply to the combination of the product in the customer's application or use of the product.

Take all necessary steps to determine the suitability of the product for the systems, machines, and equipment with which it will be used.

Know and observe all prohibitions of use applicable to this product.

NEVER USE THE PRODUCT FOR AN APPLICATION INVOLVING SERIOUS RISK TO LIFE OR PROPERTY WITHOUT ENSURING THAT THE SYSTEM AS A WHOLE HAS BEEN DESIGNED TO ADDRESS THE RISKS, AND THAT THE OMRON PRODUCT IS PROPERLY RATED AND INSTALLED FOR THE INTENDED USE WITHIN THE OVERALL EQUIPMENT OR SYSTEM.

### PROGRAMMABLE PRODUCTS

OMRON shall not be responsible for the user's programming of a programmable product, or any consequence thereof.

## Disclaimers

### CHANGE IN SPECIFICATIONS

Product specifications and accessories may be changed at any time based on improvements and other reasons. Consult with your OMRON representative at any time to confirm actual specifications of purchased product.

### DIMENSIONS AND WEIGHTS

Dimensions and weights are nominal and are not to be used for manufacturing purposes, even when tolerances are shown.

### PERFORMANCE DATA

Performance data given in this catalog is provided as a guide for the user in determining suitability and does not constitute a warranty. It may represent the result of OMRON's test conditions, and the users must correlate it to actual application requirements. Actual performance is subject to the OMRON Warranty and Limitations of Liability.

**Note: Do not use this document to operate the Unit.**

**OMRON Corporation**

Control Devices Division H.Q.  
Shiokoji Horikawa, Shimogyo-ku,  
Kyoto, 600-8530  
Japan  
Tel: (81)75-344-7109  
Fax: (81)75-344-7149

**Regional Headquarters**

**OMRON EUROPE B.V.**

Wegalaan 67-69, NL-2132 JD Hoofddorp  
The Netherlands  
Tel: (31)2356-81-300/  
Fax: (31)2356-81-388

**OMRON ELECTRONICS LLC**

1 East Commerce Drive, Schaumburg,  
IL 60173 U.S.A.  
Tel: (1)847-843-7900/Fax: (1)847-843-8568

**OMRON ASIA PACIFIC PTE. LTD.**

83 Clemenceau Avenue,  
#11-01, UE Square,  
Singapore 239920  
Tel: (65)6835-3011/Fax: (65)6835-2711

**OMRON (CHINA) CO., LTD.**

Room 2211, Bank of China Tower,  
200 Yin Cheng Zhong Road,  
PuDong New Area, Shanghai, 200120 China  
Tel: (86)21-5037-2222/Fax: (86)21-5037-2200

**Authorized Distributor:**

Note: Specifications subject to change without notice.

Cat. No. I813-E1-01  
Printed in Japan  
0208(0208)