

Transistor Remote Terminal Blocks

SRT2-□D16T

CompoBus/S Transistor I/O Terminal Blocks Offer Individual Common Terminals for Each Point

- SRT2 terminals support both high-speed communications (750 kbps) and long-distance communications (500 m) systems, switch selected
- Removable circuit blocks simplify long-term maintenance
- 3 tiers of terminals provide individual common wiring points
- DIN track and screw mounting



Ordering Information

I/O points	I/O classification	Internal I/O circuit common	Rated voltage	I/O rated voltage	Part number
16	Input	NPN (+ common)	24 VDC	24 VDC	SRT2-ID16T
		PNP (- common)			SRT2-ID16T-1
8 each	Inputs and outputs	NPN (+ common)			SRT2-MD16T
		PNP (- common)			SRT2-MD16T-1
16	Output	NPN (- common)			SRT2-OD16T
		PNP (+ common)			SRT2-OD16T-1

■ ACCESSORIES

Item	Specification	Part number
Communications cable	Flat cable, 100 m length, 4 conductor (0.75 mm ² each)	SCA1-4F10
Branch connector	Sold in packs of 10	SCN1-TH4
Extension connector	Sold in packs of 10	SCN1-TH4E
Connector terminator	Sold in packs of 10	SCN1-TH4T
Terminal block terminator	Sold in packs of 10	SRS1-T

Specifications

■ RATINGS

Inputs

Input current	6 mA max./point at 24 V and 3 mA min./point at 17 V
ON delay time	1.5 ms max.
OFF delay time	1.5 ms max.
ON voltage	15 VDC min. between each input terminal and V terminals 15 VDC min. between each input terminal and G terminals
OFF voltage	5 VDC max. between each input terminal and V terminals 5 VDC max. between each input terminal and G terminals
OFF current	1 mA max.
Insulation method	Photocoupler
Input indicators	LED (green)

Outputs

Rated output current	0.5 A/point
Residual voltage	1.2 V max.
ON delay time	0.5 ms max.
OFF delay time	1.0 ms max.
Leakage current	0.1 mA max.
Insulation method	Photocoupler
Output indicators	LED (green)

■ CHARACTERISTICS

Communications power supply voltage	14 to 26.4 VDC
I/O power supply voltage	24 VDC +10%/-15%
I/O power supply current	4 A max./common
Current consumption (See Note)	50 mA max. at 24 VDC
Connection method	Multi-drop method and T-branch method Secondary branches cannot be connected to T-branch lines.
Dielectric strength	500 VAC for 1 min between insulated circuits
Noise immunity	±1.5 kV with a pulse width of 100 ns to 1 μs
Vibration resistance	10 to 150 Hz, 1.0 mm double amplitude or 70 m/s ²
Shock resistance	200 m/s ²
Mounting strength	No damage when 100 N pull load was applied in all directions
Terminal strength	No damage when 100 N pull load was applied
Screw tightening torque	0.3 to 0.5 N • m
Ambient temperature	Operating: -10°C to 55°C (14°F to 131°F) with no icing or condensation Storage: -25°C to 65°C (-13°F to 149°F) with no icing or condensation
Ambient humidity	Operating: 35% to 85% RH with no condensation
Weight	300 g max.

Note: The above current consumption is the value with all points turned ON excluding the current consumption of the external sensor connected to the input Remote Terminal and the current consumption of the load connected to the output Remote Terminal.

Nomenclature

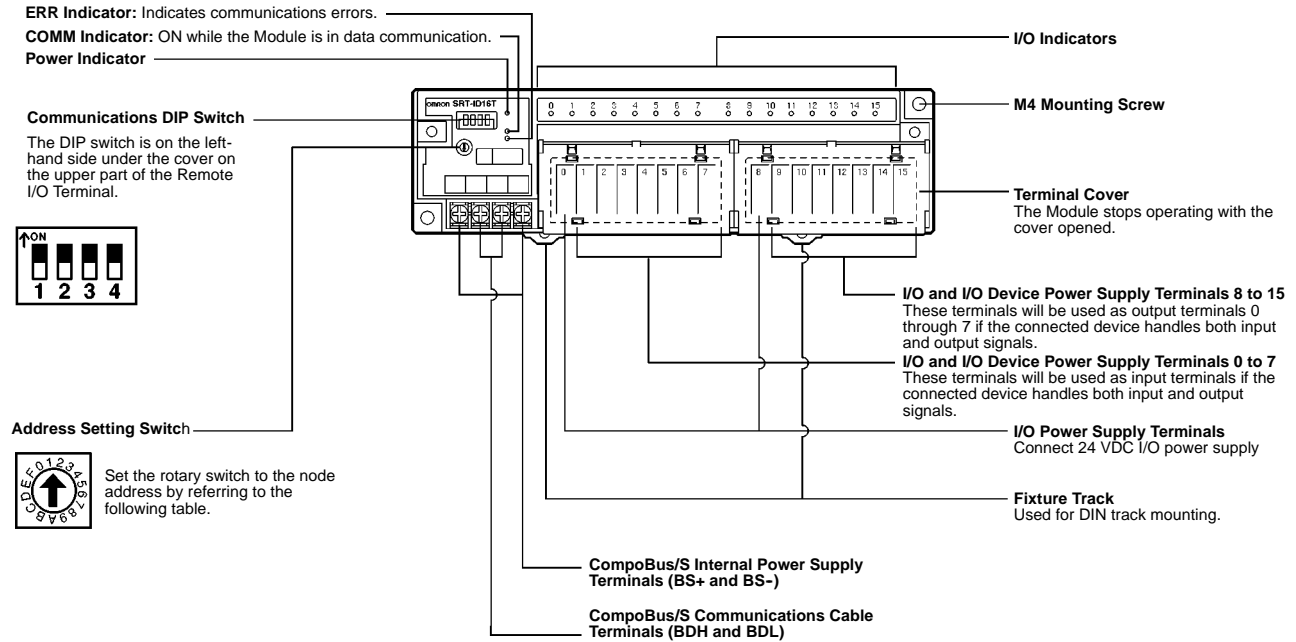

INDICATORS

Indicator	Display	Color	Meaning
PWR	Lit	Green	The communications power supply is ON.
	Not lit		The communications power supply is OFF.
COMM	Lit	Yellow	Normal communications
	Not lit		A communications error has occurred or the Module is in standby status.
ERR	Lit	Red	A communications error has occurred.
	Not lit		Normal communications or the Module is in standby status.
0 to 15	Lit	Yellow	The corresponding I/O signal is ON.
	Not lit		The corresponding I/O signal is OFF.

DIP SWITCH SETTINGS

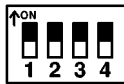

Pins 1 and 2 are reserved. The default setting is always OFF.

Baud Rate Setting

Mode	Pin 3	Setting
Long distance	ON	Sets the I/O block to communicate in a long distance (500 m at 93.75 kbps) CompoBus/S system.
High speed	OFF (default)	Sets the I/O block to communicate in a high speed (750 kbps at 100 m) CompoBus/S system.

Output HOLD/CLEAR Mode

Mode	Pin 4	Setting
HOLD	ON	Output status is maintained.
CLEAR	OFF (default)	Output status is cleared when a communications error occurs.

Node Number Settings



Node address	Setting (Hex)	Node address	Setting (Hex)	Node address	Setting (Hex)
0	0	6	6	12	C
1	1	7	7	13	D
2	2	8	8	14	E
3	3	9	9	15	F
4	4	10	A	-	-
5	5	11	B	-	-

Note: For node number settings, refer to the *CompoBus/S Operation Manual (W266)*.

Dimensions

Unit: mm (inch)

SRT2-ID16T (-1)
 SRT2-MD16T (-1)
 SRT2-OD16T (-1)

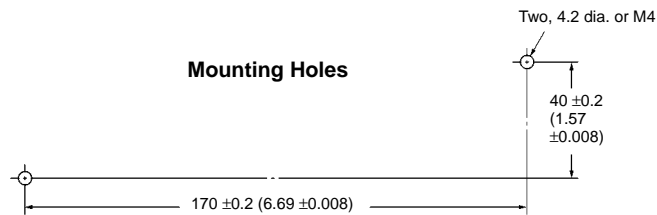
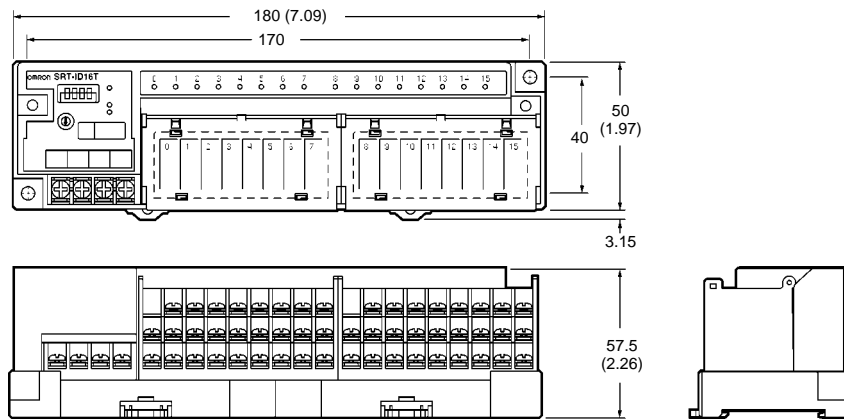
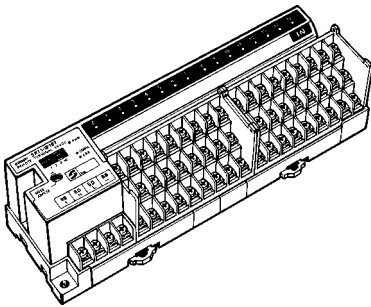

Installation

INTERNAL CIRCUIT CONFIGURATION

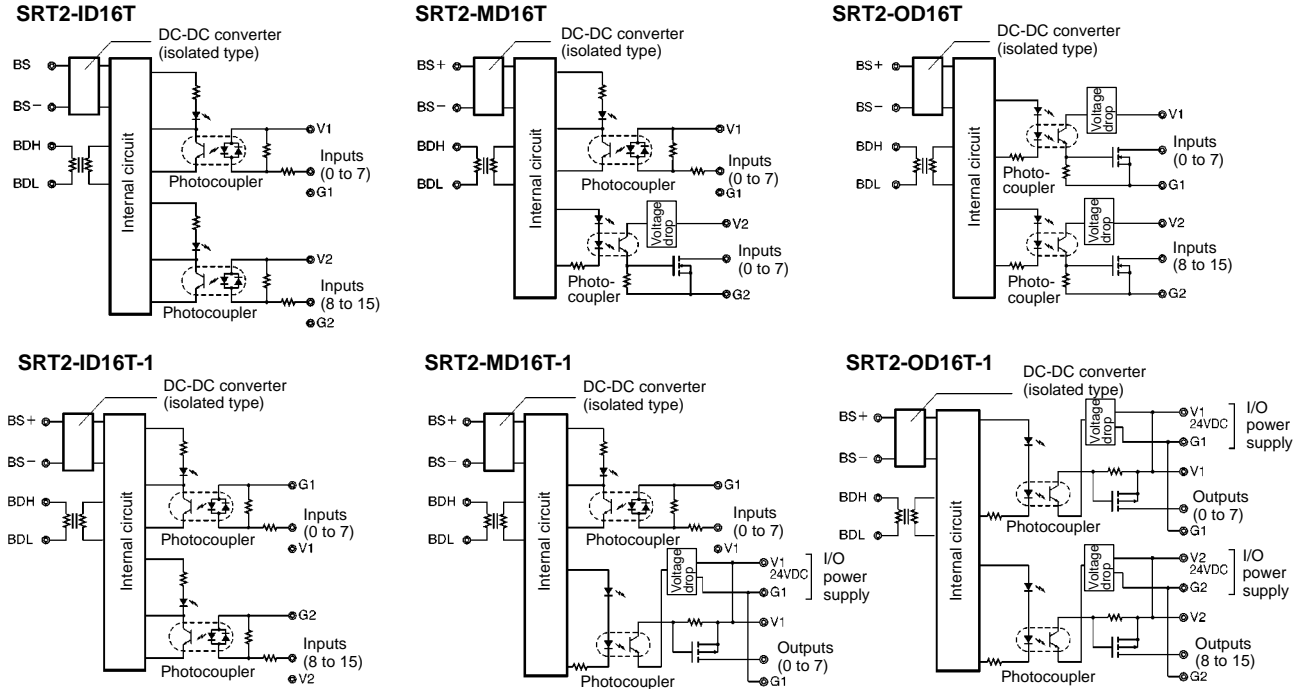

EXTERNAL CONNECTIONS

Input (NPN Models)

SRT2-ID16T, SRT2-MD16T

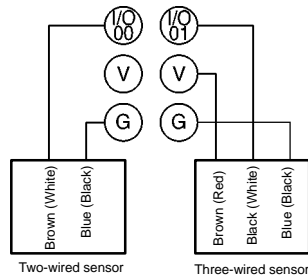

Output (NPN Models)

SRT2-OD16T, SRT2-MD16T

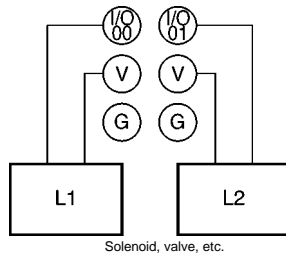

Input (PNP Models)

SRT2-ID16T-1, SRT2-MD16T-1

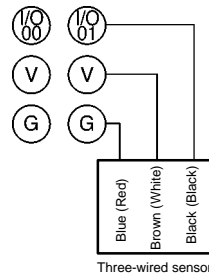

Output (PNP Models)

SRT2-OD16T-1, SRT2-MD16T-1

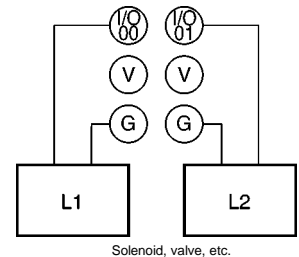

Precautions

Refer to the *CompoBus/S Operation Manual (W266)* before using the Unit.

NOTE: DIMENSIONS SHOWN ARE IN MILLIMETERS. To convert millimeters to inches divide by 25.4.

OMRON[®]**OMRON ELECTRONICS, INC.**

One East Commerce Drive
Schaumburg, IL 60173

1-800-55-OMRON**OMRON CANADA, INC.**

885 Milner Avenue
Scarborough, Ontario M1B 5V8

416-286-6465