

AC centrifugal fan

backward-curved, single-intake

ebm-papst Mulfingen GmbH & Co. KG

Bachmühle 2 · D-74673 Mulfingen

Phone +49 7938 81-0

Fax +49 7938 81-110

info1@de.ebmpapst.com

www.ebmpapst.com

Limited partnership · Headquarters Mulfingen

Amtsgericht (court of registration) Stuttgart · HRA 590344

General partner Elektrobau Mulfingen GmbH · Headquarters Mulfingen

Amtsgericht (court of registration) Stuttgart · HRB 590142

Nominal data

Type	R2E250-AL05-16		
Motor	M2E068-GA		
Phase		1~	1~
Nominal voltage	VAC	230	230
Frequency	Hz	60	60
Method of obtaining data		fa	fa
Valid for approval/standard		CE	UL 2111
Speed (rpm)	min ⁻¹	3000	3000
Power consumption	W	295	310
Current draw	A	1.3	
Capacitor	µF	5	5
Capacitor voltage	VDB	400	400
Capacitor standard		P2 (CE)	
Min. back pressure	Pa	0	0
Min. back pressure	inH ₂ O	0	0
Min. ambient temperature	°C	-25	-25
Max. ambient temperature	°C	60	60

ml = Max. load · me = Max. efficiency · fa = Free air · cs = Customer specification · ce = Customer equipment
Subject to change



Technical description

Weight	4 kg
Fan size	250 mm
Rotor surface	Painted black
Impeller material	Sheet steel, galvanized and painted black
Number of blades	11
Direction of rotation	Clockwise, viewed toward rotor
Degree of protection	IP00; (motor)
Insulation class	"B"
Moisture (F) / Environmental (H) protection class	H0+
Max. permitted ambient temp. for motor (transport/storage)	+ 80 °C
Min. permitted ambient temp. for motor (transport/storage)	- 40 °C
Installation position	Any
Condensation drainage holes	None, open rotor
Mode	S1
Motor bearing	Ball bearing
Touch current according to IEC 60990 (measuring circuit Fig. 4, TN system)	< 0.75 mA
Motor protection	Thermal overload protector (TOP) internally connected
With cable	Variable
Protection class	I (if protective earth is connected by customer to the housing's connection point)
Conformity with standards	EN 60335-1; CE
Approval	UL 2111; CSA C22.2 No. 77; CCC

AC centrifugal fan

backward-curved, single-intake

Product drawing

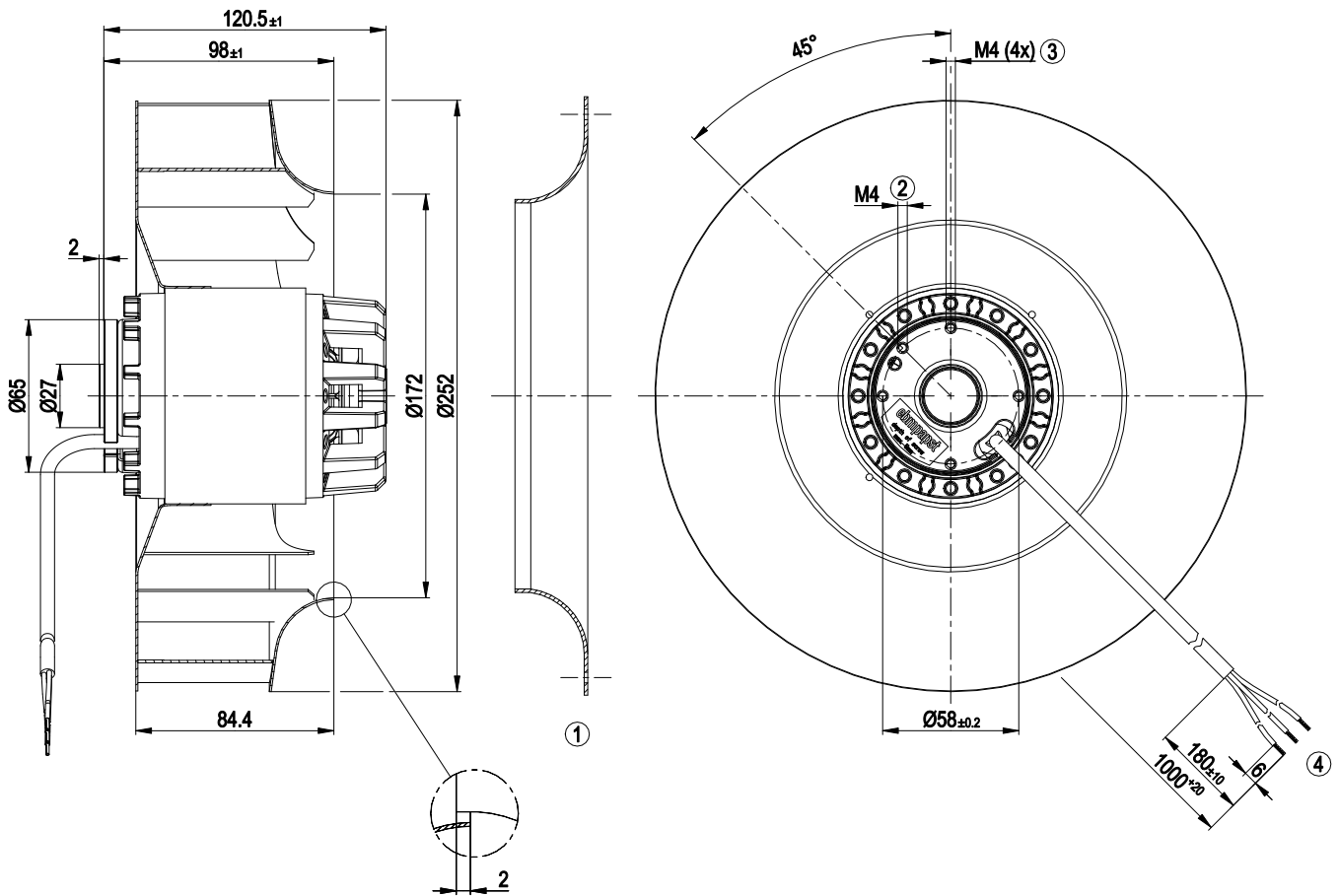

1	Accessory part: inlet ring 96359-2-4013 not included in scope of delivery
2	Ground connection point
	Max. clearance for screw 5 mm
3	Max. clearance for screw 5 mm
4	Cable PFA AWG20, 3x crimped splices



Accessory part

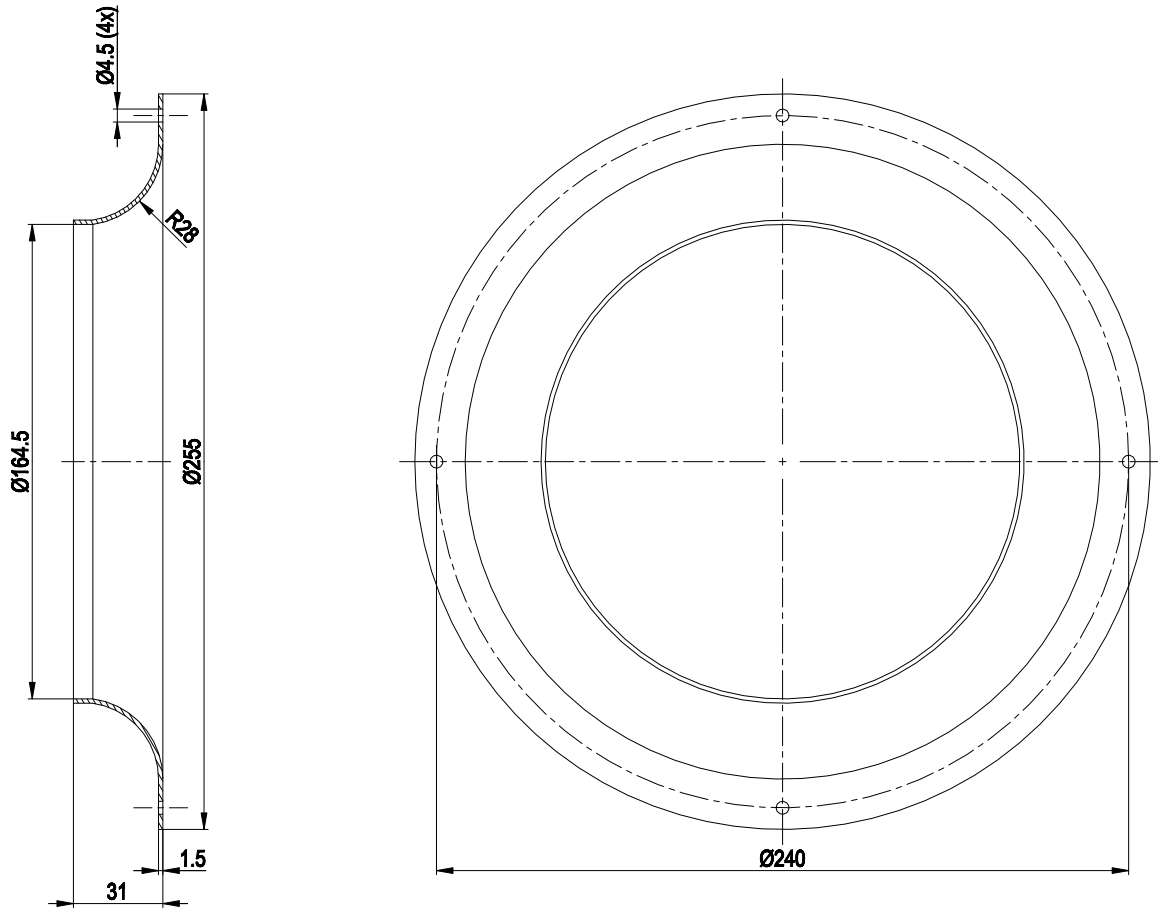

Accessory part: inlet ring 96359-2-4013 not included in scope of delivery

Connection diagram

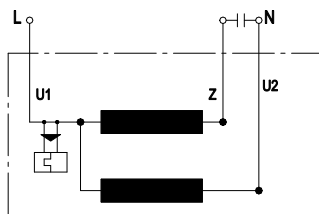

U1	blue	Z	brown	U2	black
----	------	---	-------	----	-------

Curves: Air performance 60 Hz

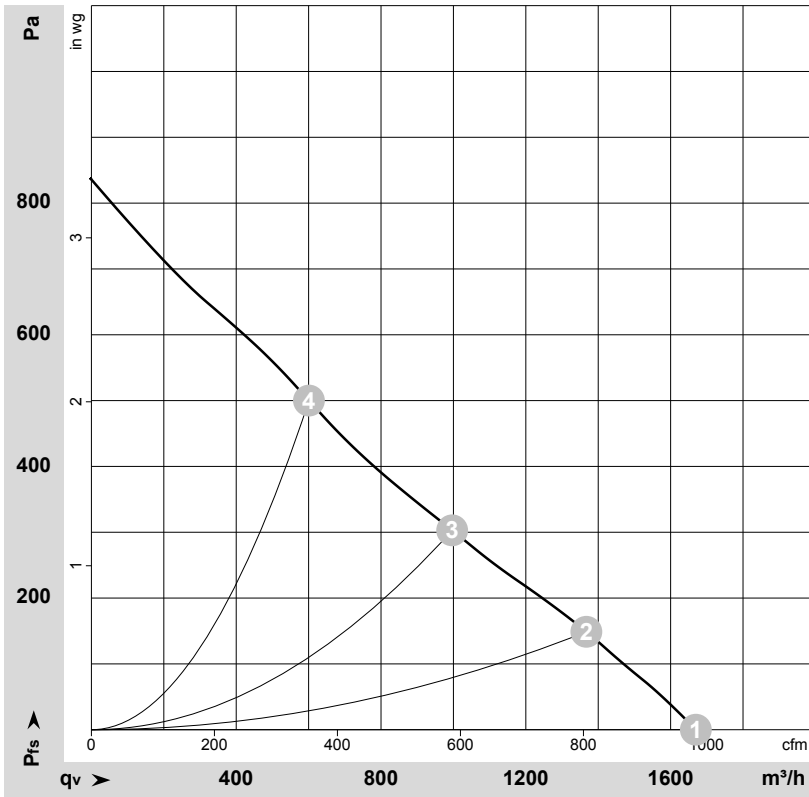

$\rho = 1.15 \text{ kg/m}^3 \pm 2 \%$

Measurement: LU-31361-1

Air performance measured according to ISO 5801 installation category A. For detailed information on the measurement setup, contact ebmpapst. Intake sound level: Sound power level according to ISO 13347 / sound pressure level measured at 1 m distance from fan axis. The values given are valid under the specified measuring conditions and may vary due to conditions of installation. For deviations from the standard configuration, the parameters have to be checked on the installed unit.

Measured values

	U	f	n	P _e	I	q _v	P _{fs}	q _v	P _{fs}
	V	Hz	min ⁻¹	W	A	m ³ /h	Pa	cfm	inH ₂ O
1	230	60	3000	295	1.30	1670	0	985	0.00
2	230	60	2860	338	1.48	1365	150	805	0.60
3	230	60	2670	383	1.69	995	300	585	1.20
4	230	60	2770	358	1.58	600	500	355	2.01

U = Power supply · f = Frequency · n = Speed (rpm) · P_e = Power consumption · I = Current draw · q_v = Air flow · P_{fs} = Pressure increase