

## Engraving material - GPE 20X 8 WH - 0806945

Please be informed that the data shown in this PDF Document is generated from our Online Catalog. Please find the complete data in the user's documentation. Our General Terms of Use for Downloads are valid (<http://phoenixcontact.com/download>)

Engraving material, Sheet, white, unlabeled, can be labeled with: PLOTMARK, ENGRAVING UNIT, CMS-P1-PLOTTER, P1 ENGRAVING UNIT, mounting type: adhesive, lettering field size: 20 mm x 8 mm, Number of individual labels: 88



### Your advantages

- ✔ Can be labeled easily using the CMS-P1-PLOTTER
- ✔ Can be engraved using the P1 ENGRAVING UNIT
- ✔ Labeling service: Phoenix Contact can custom-label all GPE ... markers according to your requirements
- ✔ The adhesive foil used ensures good adhesive properties, even on uneven surfaces
- ✔ Two-layer material
- ✔ The label sheet consists of prefabricated, individual self-adhesive labels

### Key Commercial Data

Packing unit	1 pc
Minimum order quantity	10 pc
GTIN	 4 017918 145019
GTIN	4017918145019
Weight per Piece (excluding packing)	18.860 g
Custom tariff number	39203000
Country of origin	Germany

### Technical data

#### Dimensions

Length (b)	8 mm
Width (a)	20 mm
Height (c)	8 mm

## Engraving material - GPE 20X 8 WH - 0806945

### Technical data

#### Ambient conditions

Ambient temperature (operation)	-20 °C ... 85 °C
Recommended storage conditions	20°C/50% relative humidity. Storage in the original packaging is recommended.

#### General

Note	Can be labeled with CMS
Color	white
Components	free from silicone and halogen
Material	TRANSPLY-ABS
Wipe resistance	DIN EN 61010-1 (VDE 0411-1)
Number of individual labels	88
Number of individual labels per row	4
Adhesive	Acrylic
Printability	Engraving
	Plotter
Device	5144615 CMS-P1-PLOTTER
	5145546 P1 ENGRAVING UNIT
Adhesive strength	50 µm
Marking mounting type	adhesive

#### Standards and Regulations

Wipe resistance	DIN EN 61010-1 (VDE 0411-1)
-----------------	-----------------------------

### Drawings

# Engraving material - GPE 20X 8 WH - 0806945

Dimensional drawing

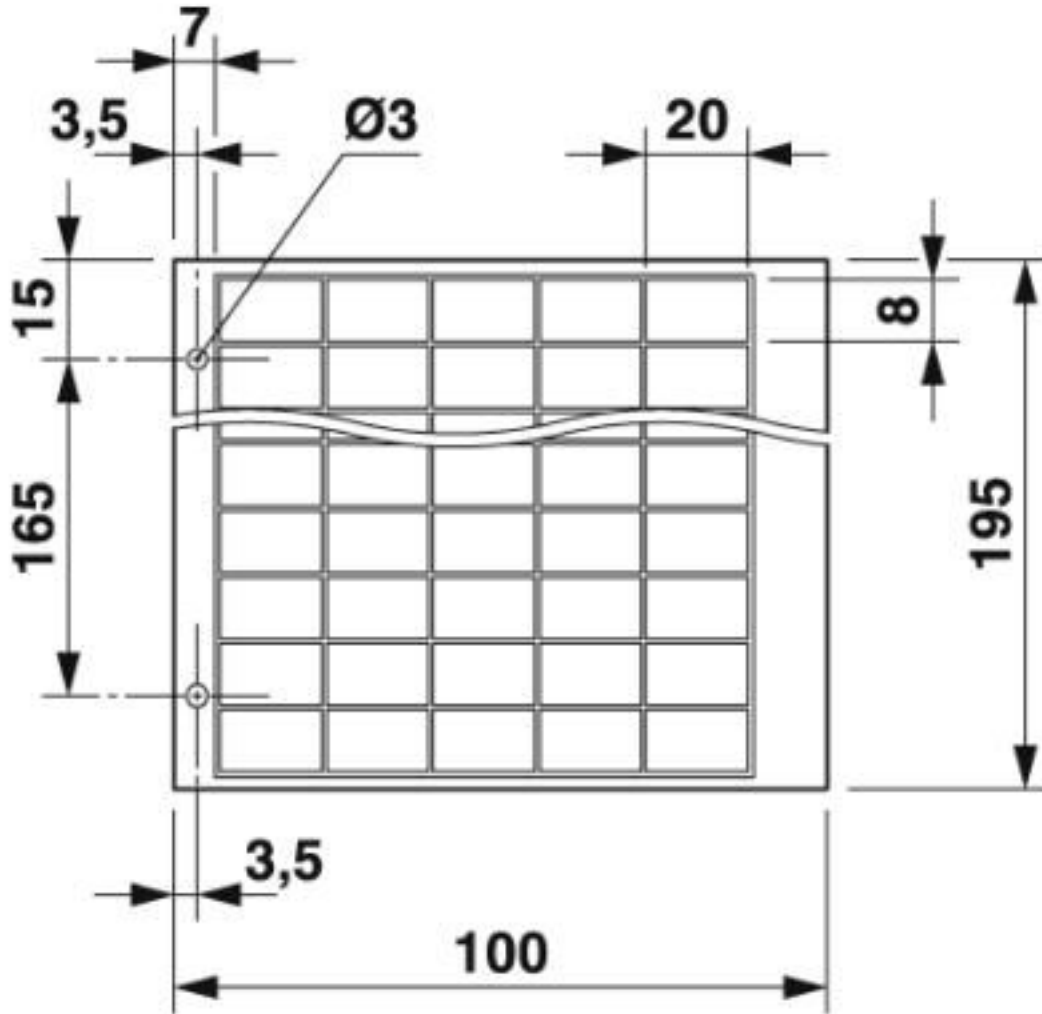

## Classifications

eCl@ss

eCl@ss 10.0.1	27400629
eCl@ss 4.0	24190200
eCl@ss 4.1	24190200
eCl@ss 5.0	27149100
eCl@ss 5.1	27141100
eCl@ss 6.0	27149100
eCl@ss 7.0	27149129
eCl@ss 8.0	27149129

## Engraving material - GPE 20X 8 WH - 0806945

### Classifications

#### eCl@ss

eCl@ss 9.0	27400629
------------	----------

#### ETIM

ETIM 2.0	EC000761
ETIM 3.0	EC000761
ETIM 4.0	EC000761
ETIM 5.0	EC001288
ETIM 6.0	EC001288
ETIM 7.0	EC001288

#### UNSPSC

UNSPSC 6.01	30211811
UNSPSC 7.0901	39121410
UNSPSC 11	39121410
UNSPSC 12.01	39121410
UNSPSC 13.2	39131504
UNSPSC 18.0	39131504
UNSPSC 19.0	39131504
UNSPSC 20.0	39131504
UNSPSC 21.0	39131504