

Seal - HC-B 16-FL-MDI - 1410945

Please be informed that the data shown in this PDF Document is generated from our Online Catalog. Please find the complete data in the user's documentation. Our General Terms of Use for Downloads are valid (<http://phoenixcontact.com/download>)



Flange seal, for HEAVYCON type B16 panel mounting base, self-adhesive, foam rubber made from cellular rubber, color: black

RoHS

Key Commercial Data

Packing unit	1 pc
Minimum order quantity	10 pc
GTIN	 4 046356 893459
GTIN	4046356893459
Custom tariff number	40169300
Country of origin	Germany

Technical data

Dimensions

Height	3 mm
--------	------

Ambient conditions

Ambient temperature (operation)	-40 °C ... 125 °C
---------------------------------	-------------------

General

Material	Cellular rubber
Assembly instructions	Not for HC-...EMC housings

Environmental Product Compliance

China RoHS	Environmentally friendly use period: unlimited = EFUP-e
	No hazardous substances above threshold values

Seal - HC-B 16-FL-MDI - 1410945

Drawings

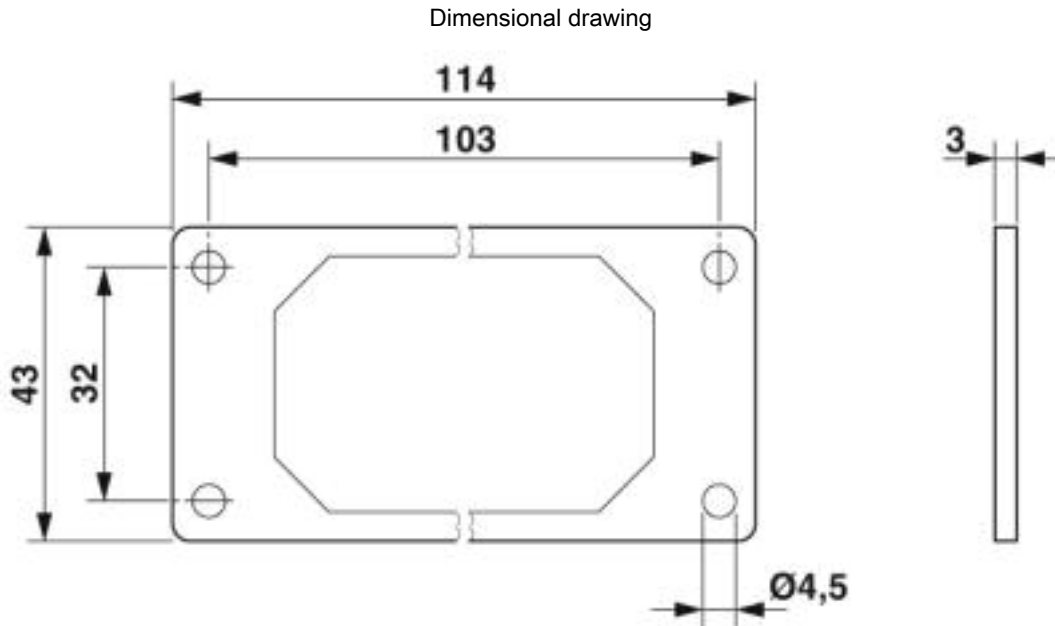

Dimensional drawing

Classifications

eCl@ss

eCl@ss 5.1	27379100
eCl@ss 6.0	27379200
eCl@ss 7.0	27379201
eCl@ss 8.0	27379201
eCl@ss 9.0	27141137

ETIM

ETIM 4.0	EC002498
ETIM 5.0	EC002498
ETIM 6.0	EC000761

UNSPSC

UNSPSC 13.2	39131505
UNSPSC 19.0	39131505