

Panel feed-through - QPD W 4PE2,5 M25 FC BK - 1582567

Please be informed that the data shown in this PDF Document is generated from our Online Catalog. Please find the complete data in the user's documentation. Our General Terms of Use for Downloads are valid (<http://phoenixcontact.com/download>)



Panel feed-through, QUICKON connection, number of positions: 4+PE, 1 mm² ... 2.5 mm², 690 V, 20 A, black, without QUICKON nut, assembly thread: M25, Slip-on connection (For slip-on sleeves according to DIN 46247-2)

Your advantages

- ✓ Innovative and time saving - QUICKON fast connection for time saving of up to 80 % for on-site connection
- ✓ Convenient: quick and easy assembly without special tools
- ✓ Robust throughout: housing with IP68/IP69K and IK07 protection for a wide range of applications
- ✓ Safer connection thanks to polarization against mismatching and touch-proof protection according to DIN EN 0105
- ✓ Efficient - by using panel feed-throughs, devices no longer need to be opened in order to connect cables



Key Commercial Data

Packing unit	1 pc
GTIN	 4 046356 662000
GTIN	4046356662000
Weight per Piece (excluding packing)	40.000 g
Custom tariff number	85366990
Country of origin	Poland

Technical data

General

Type	QPD 5x2,5
Color	black
Locking type	Screw locking
Connection method	QUICKON connection
	IDC connection

Panel feed-through - QPD W 4PE2,5 M25 FC BK - 1582567

Technical data

General

Number of positions	5
Note number of positions	4+PE
Wrench size, union nut	27 mm
Tightening torque, union nut	10 Nm
Tightening torque, counter nut	5 Nm
Wrench size, counter nut	30 mm
Number of connections	10
Conductor cross section flexible min.	1 mm ²
Conductor cross section flexible max.	2.5 mm ²
Conductor cross section solid min.	1 mm ²
Conductor cross section solid max.	2.5 mm ²
Conductor cross section AWG min.	16
Conductor cross section AWG max.	14
Dimensions of slip-on connection	4.8 x 0.8 mm

Cabel

Structure of individual litz in acc. with VDE 0295 / smallest wire diameter	VDE 0295 class 1 to 6/min. 0.15 mm
Wire insulation material	PVC/PE/TPE/rubber
Wire diameter including insulation	2 mm ... 3.8 mm
Position marking	1, 2, 3, N, PE

Ambient conditions

Degree of protection	IP66
	IP68 (2 m / 24 h)
	IP69K
Ambient temperature (operation)	-40 °C ... 100 °C
Ambient temperature (storage/transport)	-40 °C ... 80 °C
Temperature when conductor connected	-5 °C ... 50 °C

Electrical characteristics

Nominal current I _N	20 A
Nominal voltage U _N	690 V AC
	690 V DC
Rated current	20 A
Rated voltage (III/3)	690 V
Rated voltage (III/2)	1000 V
Rated voltage (II/2)	1000 V
Rated surge voltage (III/3)	6 kV
Rated surge voltage (III/2)	8 kV

Panel feed-through - QPD W 4PE2,5 M25 FC BK - 1582567

Technical data

Electrical characteristics

Rated surge voltage (II/2)	8 kV
----------------------------	------

Mechanical characteristics

QUICKON connectability	max. 10
Category of shock impact	IK07

Material data

Contact material	Cu
Contact surface material	silver-plated
Contact carrier material	PA
Insulating material	PA
Flammability rating according to UL 94	V0
Overvoltage category	III
Degree of pollution	3

Standards and Regulations

Category of shock impact	IK07
Flammability rating according to UL 94	V0

Environmental Product Compliance

China RoHS	Environmentally friendly use period: unlimited = EFUP-e
	No hazardous substances above threshold values

Drawings

Panel feed-through - QPD W 4PE2,5 M25 FC BK - 1582567

Diagram

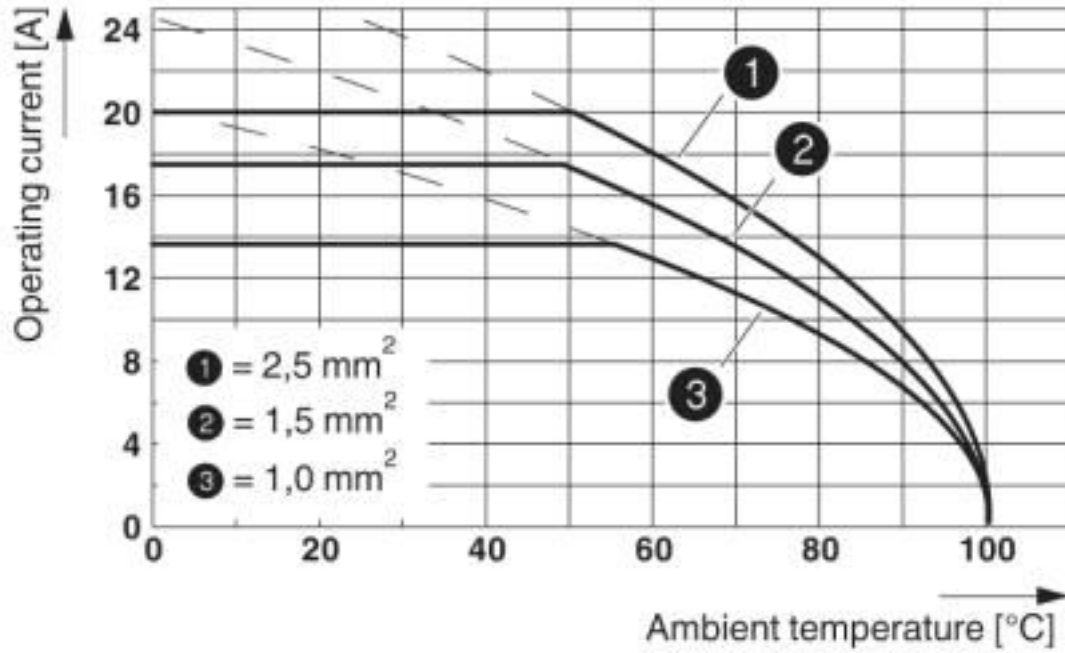

Dimensional drawing

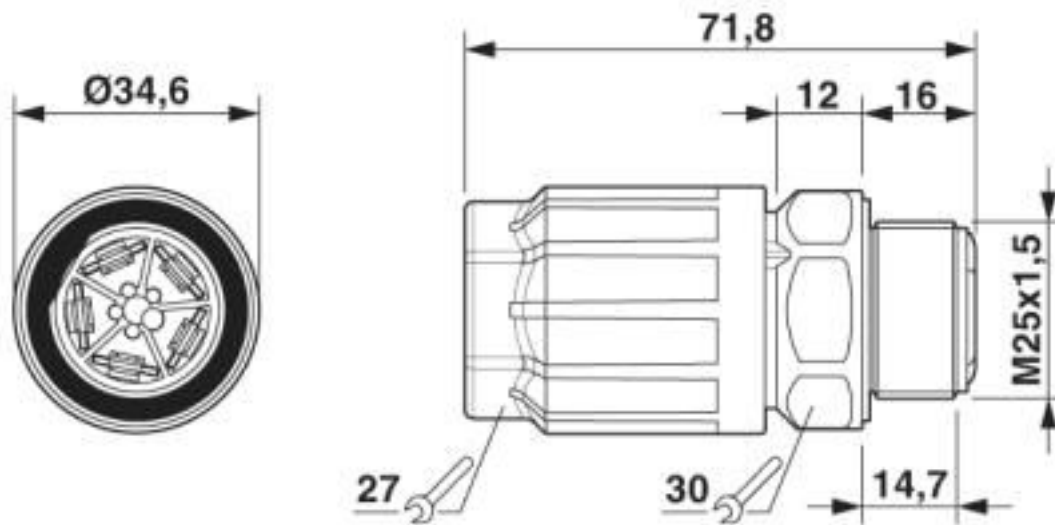

QPD W 4PE2.5 M25 dimensional drawing

Panel feed-through - QPD W 4PE2,5 M25 FC BK - 1582567

Dimensional drawing

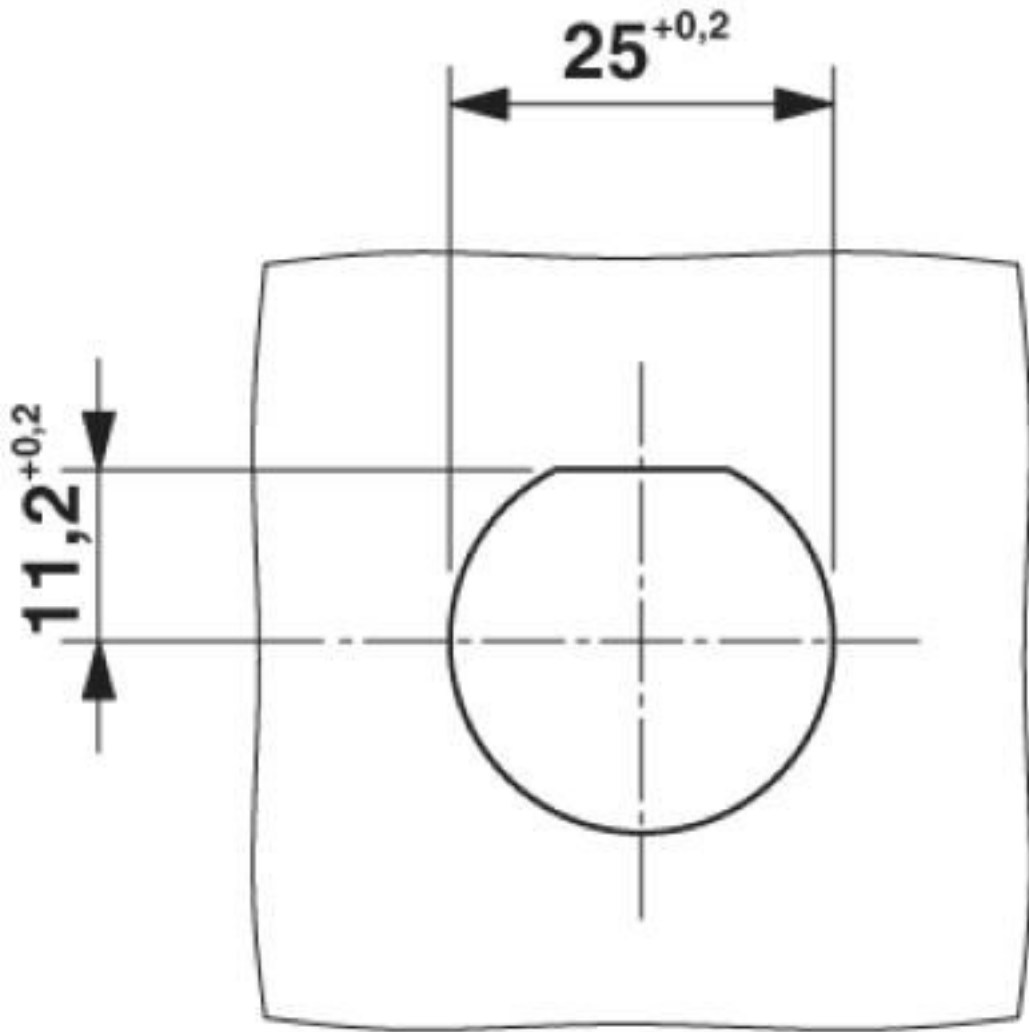

Panel cutout

Classifications

eCl@ss

eCl@ss 10.0.1	27440602
eCl@ss 4.0	27140800
eCl@ss 4.1	27140800
eCl@ss 5.0	27143400
eCl@ss 5.1	27143400

Panel feed-through - QPD W 4PE2,5 M25 FC BK - 1582567

Classifications

eCl@ss

eCl@ss 6.0	27143400
eCl@ss 7.0	27440602
eCl@ss 8.0	27440602
eCl@ss 9.0	27440602

ETIM

ETIM 3.0	EC000516
ETIM 4.0	EC000516
ETIM 5.0	EC002566
ETIM 6.0	EC002566
ETIM 7.0	EC002566

UNSPSC

UNSPSC 6.01	30211923
UNSPSC 7.0901	39121522
UNSPSC 11	39121522
UNSPSC 12.01	39121522
UNSPSC 13.2	39121522
UNSPSC 18.0	39121522
UNSPSC 19.0	39121522
UNSPSC 20.0	39121522
UNSPSC 21.0	39121522

Approvals

Approvals

Approvals

EAC / EAC / DNV GL / IECCEB Scheme / UL Listed / cUL Listed / VDE Zeichengenehmigung / cULus Listed

Ex Approvals

Approval details

EAC		RU C- DE.AI30.B.01102
-----	--	--------------------------

Panel feed-through - QPD W 4PE2,5 M25 FC BK - 1582567

Approvals

EAC			RU C- DE.BL08.B.00511
-----	---	--	--------------------------

DNV GL		https://approvalfinder.dnvgl.com/	TAE00003J5
--------	---	---	------------

IECEE CB Scheme		http://www.iecee.org/	DE1-61559
-----------------	---	---	-----------

UL Listed		http://database.ul.com/cgi-bin/XYV/template/LISEXT/1FRAME/index.htm	FILE E 221474
Nominal voltage UN		600 V	
Nominal current IN		10 A	
mm ² /AWG/kcmil		16	

cUL Listed		http://database.ul.com/cgi-bin/XYV/template/LISEXT/1FRAME/index.htm	FILE E 221474
Nominal voltage UN		600 V	
Nominal current IN		10 A	
mm ² /AWG/kcmil		16	

VDE Zeichengenehmigung		http://www2.vde.com/de/Institut/Online-Service/VDE-gepruefteProdukte/Seiten/Online-Suche.aspx	40029149
Nominal voltage UN		690 V	
Nominal current IN		20 A	
mm ² /AWG/kcmil		1-2.5	

Panel feed-through - QPD W 4PE2,5 M25 FC BK - 1582567

Approvals

cULus Listed



Accessories

Accessories

Coding element

Coding profile - CP-QPD 5X2,5 - 1404530



Coding profile, red, for insertion into the 5-pos. QUICKON dome and connector, can be positioned in 72° increments.

Mounting material

Nut - Q-MU M25 - 1640715



Nut (plastic) to lock the contact carrier from the inside of the device

Protective cap

Protective cap - QPD QSK BK 5X2,5 FS - 1404525



Protective cap, plastic, for QUICKON connection, black, with retaining cord, IP68

Panel feed-through - QPD W 4PE2,5 M25 FC BK - 1582567

Accessories

Protective cap - QPD QSK 5X2,5 - 1404528



Protective cap, transparent plastic, for 5x 2.5 mm² QPD QUICKON connection, IP50.

Socket spanner

Socket wrench - QSS 27 - 1670646



Allen wrench, for loosening and fastening the QUICKON union nut, WAF 27 mm