

Contact insert - VS-15-ST-DSUB-EG - 1688874

Please be informed that the data shown in this PDF Document is generated from our Online Catalog. Please find the complete data in the user's documentation. Our General Terms of Use for Downloads are valid (<http://phoenixcontact.com/download>)



D-SUB contact insert, shell size 2, with 15 signal contacts, type of contact pin, with solder cup, straight, fixing with a 3 mm hole, for panel mounting frame and sleeve housing VS-15-...



Key Commercial Data

Packing unit	1 pc
Minimum order quantity	10 pc
Weight per Piece (excluding packing)	7.3 g
Custom tariff number	85366990
Country of origin	Germany

Technical data

Mechanical characteristics

Number of positions	15
Connection profile	D-SUB 15
Insertion/withdrawal cycles	≥ 50
Connection method	Solder cup
Conductor cross section	0.5 mm ²
Connection cross section AWG	20
Insertion force per signal contact	≤ 3.40 N
Mounting type	Hole

Ambient conditions

Ambient temperature (operation)	-55 °C ... 125 °C
---------------------------------	-------------------

Material data

Flammability rating according to UL 94	V0
Housing material	Steel, yellow chromated
Contact carrier material	Polyester GF

Contact insert - VS-15-ST-DSUB-EG - 1688874

Technical data

Material data

Contact material	Copper alloy
Contact surface material	Hard gold-plated over nickel

Electrical characteristics

Number of positions	15
Rated current	5 A
Overvoltage category	III
Degree of pollution	2

Standards and Regulations

Flammability rating according to UL 94	V0
--	----

Classifications

eCl@ss

eCl@ss 4.0	27140816
eCl@ss 4.1	27260701
eCl@ss 5.0	27260701
eCl@ss 5.1	27260701
eCl@ss 6.0	27260705
eCl@ss 7.0	27440309
eCl@ss 8.0	27440205
eCl@ss 9.0	27440205

ETIM

ETIM 2.0	EC000438
ETIM 3.0	EC000438
ETIM 4.0	EC000438
ETIM 5.0	EC000438

UNSPSC

UNSPSC 6.01	30211923
UNSPSC 7.0901	39121522
UNSPSC 11	39121522
UNSPSC 12.01	39121522
UNSPSC 13.2	39121522

Approvals

Approvals

Contact insert - VS-15-ST-DSUB-EG - 1688874

Approvals

Approvals

EAC / EAC / UL Recognized

Ex Approvals

Approvals submitted

Approval details

EAC

EAC

UL Recognized 

Drawings

Schematic diagram

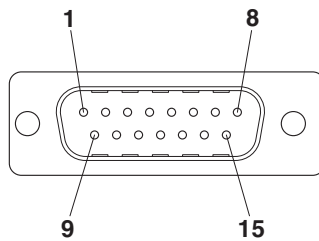

Contact insert - VS-15-ST-DSUB-EG - 1688874

Dimensional drawing

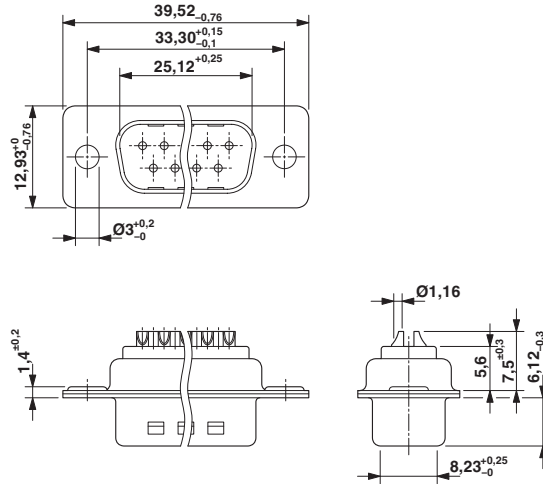

D-SUB contact insert