

Inline terminal - IB IL 24 DI 4-XC-PAC - 2701152

Please be informed that the data shown in this PDF Document is generated from our Online Catalog. Please find the complete data in the user's documentation. Our General Terms of Use for Downloads are valid (<http://phoenixcontact.com/download>)



Inline XC, Digital input terminal, Digital inputs: 4, 24 V DC, connection method: 3-wire, Extreme conditions version, transmission speed in the local bus: 500 kbps, degree of protection: IP20, including Inline connector and labeling field

The figure shows the standard item

Product Description

The terminal is designed for use within an Inline station. It is used to acquire digital signals.

Your advantages

- 4 digital inputs
- Connection of sensors in 2 and 3-wire technology
- Maximum permissible load current per sensor: 250 mA
- Maximum permissible load current from the terminal: 1 A
- Diagnostic and status indicators
- Can be used under extreme ambient conditions
- Extended temperature range of -40 °C ... +70 °C (see "Tested successfully: use under extreme ambient conditions" in the data sheet)
- Coated PCBs

Key Commercial Data

Packing unit	1 pc
GTIN	
GTIN	4046356713795
Weight per Piece (excluding packing)	100.000 g
Custom tariff number	85389091
Country of origin	Germany

Inline terminal - IB IL 24 DI 4-XC-PAC - 2701152

Technical data

Note

Utilization restriction	EMC: class A product, see manufacturer's declaration in the download area
-------------------------	---

Dimensions

Width	12.2 mm
Height	140.5 mm
Depth	71.5 mm
Note on dimensions	Housing dimensions

Ambient conditions

Ambient temperature (operation)	-25 °C ... 55 °C (Standard)
	-40 °C ... 70 °C (Extended, see section "Tested successfully: use under extreme ambient conditions" in the data sheet.)
Ambient temperature (storage/transport)	-40 °C ... 85 °C
Permissible humidity (operation)	10 % ... 95 % (according to DIN EN 61131-2)
Permissible humidity (storage/transport)	10 % ... 95 % (according to DIN EN 61131-2)
Air pressure (operation)	70 kPa ... 106 kPa (up to 3000 m above sea level)
Air pressure (storage/transport)	70 kPa ... 106 kPa (up to 3000 m above sea level)
Degree of protection	IP20

General

Mounting type	DIN rail
Net weight	66 g
Note on weight specifications	with connector
Operating mode	Process data operation with 4 bits

Interfaces

Designation	Inline local bus
No. of channels	2
Connection method	Inline data jumper
Transmission speed	500 kbps

Inline potentials

Designation	Communications power (U_L)
Supply voltage	7.5 V DC
Current consumption	max. 40 mA
Power consumption	max. 0.3 W (at U_L)
Designation	Segment circuit supply (U_S)
Supply voltage	24 V DC (via voltage jumper)
Supply voltage range	19.2 V DC ... 30 V DC (including all tolerances, including ripple)

Inline terminal - IB IL 24 DI 4-XC-PAC - 2701152

Technical data

Inline potentials

Current consumption	max. 1 A
	0 A

Digital inputs

Input name	Digital inputs
Description of the input	EN 61131-2 type 1
Connection method	Spring-cage connection
Connection technology	3-wire
Number of inputs	4
Typical response time	< 1 ms
Type of protection	Short-circuit and overload protection
Input voltage	24 V DC
Input voltage range "0" signal	-3 V DC ... 5 V DC
Input voltage range "1" signal	15 V DC ... 30 V DC
Nominal input current at U_{IN}	min. 3 mA (at nominal voltage)

Electrical isolation

Test section	5 V supply, incoming remote bus/7.5 V supply (bus logics) 500 V AC 50 Hz 1 min.
	5 V supply, outgoing remote bus/7.5 V supply (bus logics) 500 V AC 50 Hz 1 min.
	7.5 V supply (bus logics)/24 V supply (I/O) 500 V AC 50 Hz 1 min.
	24 V supply (I/O) / functional earth ground 500 V AC 50 Hz 1 min.

Standards and Regulations

Connection in acc. with standard	CUL
Protection class	III, IEC 61140, EN 61140, VDE 0140-1

Drawings

Inline terminal - IB IL 24 DI 4-XC-PAC - 2701152

Connection diagram

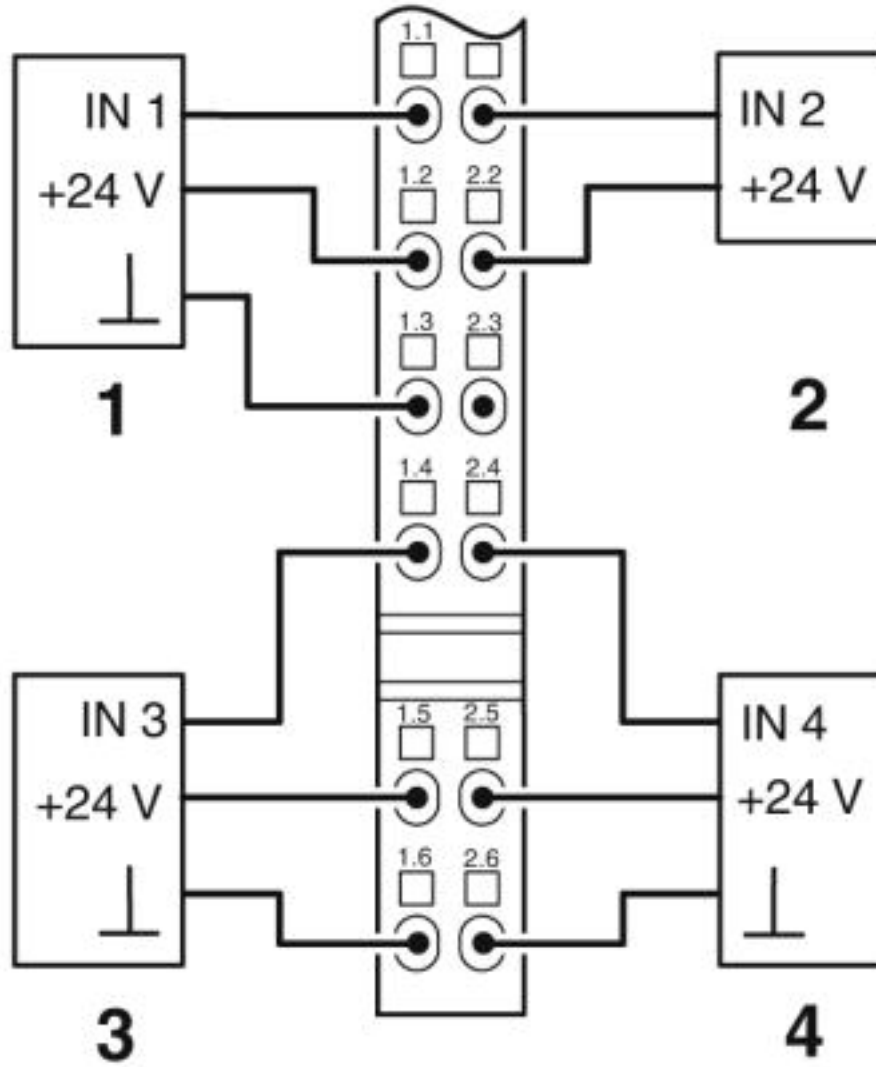

Inline terminal - IB IL 24 DI 4-XC-PAC - 2701152

Dimensional drawing

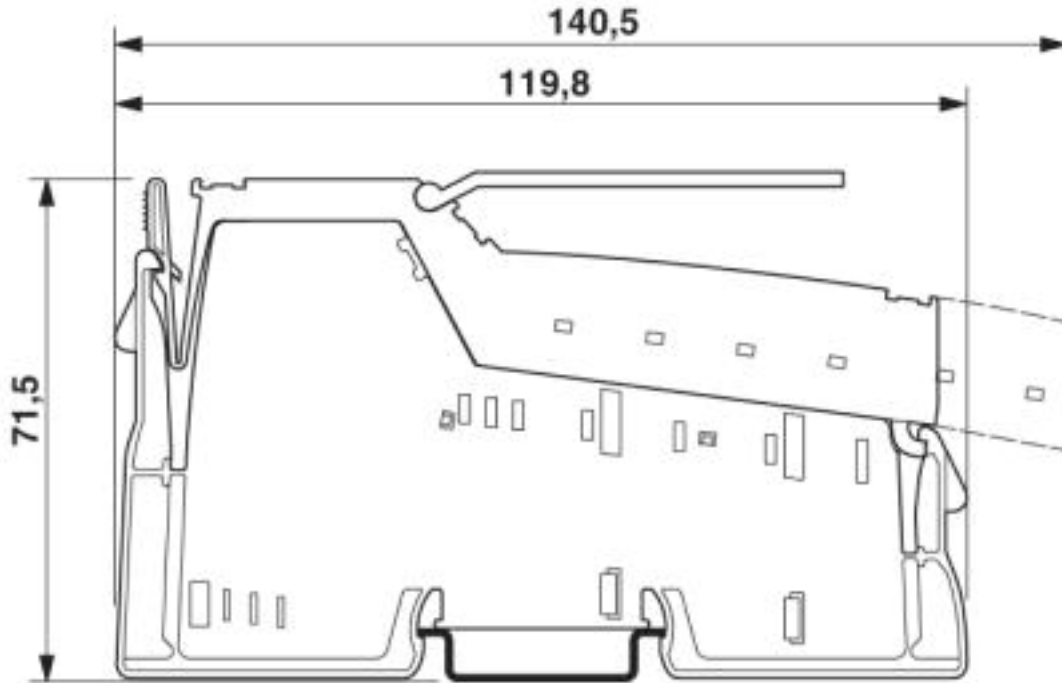

Classifications

eCl@ss

eCl@ss 4.0	27240400
eCl@ss 4.1	27240400
eCl@ss 5.0	27242200
eCl@ss 5.1	27242600
eCl@ss 6.0	27242600
eCl@ss 7.0	27242604
eCl@ss 8.0	27242604
eCl@ss 9.0	27242604

ETIM

ETIM 2.0	EC001433
ETIM 3.0	EC001599
ETIM 4.0	EC001599
ETIM 5.0	EC001599
ETIM 6.0	EC001599
ETIM 7.0	EC001599

Inline terminal - IB IL 24 DI 4-XC-PAC - 2701152

Classifications

UNSPSC

UNSPSC 6.01	43172015
UNSPSC 7.0901	43201404
UNSPSC 11	39121311
UNSPSC 12.01	39121311
UNSPSC 13.2	32151602

Approvals

Approvals

Approvals

UL Recognized / cUL Recognized / cULus Recognized

Ex Approvals

Approval details

UL Recognized		http://database.ul.com/cgi-bin/XYV/template/LISEXT/1FRAME/index.htm	FILE E 140324
---------------	--	---	---------------

cUL Recognized		http://database.ul.com/cgi-bin/XYV/template/LISEXT/1FRAME/index.htm	FILE E 140324
----------------	--	---	---------------

cULus Recognized			
------------------	--	--	--

Accessories

Accessories

Labeling panel

Inline terminal - IB IL 24 DI 4-XC-PAC - 2701152

Accessories

Labeling field - IB IL FIELD 2 - 2727501

Labeling field, width: 12.2 mm



Plug

Inline connector - IB IL SCN-8 - 2726337

Connector, for digital 1, 2 or 8-channel Inline terminals



Inline connector - IB IL SCN-8-CP - 2727608

Inline connector, colored



Terminal marking

Insert strip - ESL 62X10 - 0809492

Insert strip, Sheet, white, unlabeled, can be labeled with: Office printing systems: Laser printer, mounting type: insert, lettering field size: 62 x 10 mm, Number of individual labels: 72

