

## Electronic device circuit breaker - CB E1 24DC/10A S-C P - 2800928

Please be informed that the data shown in this PDF Document is generated from our Online Catalog. Please find the complete data in the user's documentation. Our General Terms of Use for Downloads are valid (<http://phoenixcontact.com/download>)



Electronic device circuit breaker, 1-pos., active current limitation, status output and control input, plug for base element.

### Your advantages

- ✓ Compact design with precise nominal current levels
- ✓ Modular expansion possible thanks to the uniform, plug-in housing concept
- ✓ Sophisticated remote signaling concept enables monitoring from any location
- ✓ The control input can be switched by means of remote control
- ✓ Active current limitation, even when switching capacitive loads
- ✓ Supply/remote signaling can be bridged with CLIPLINE complete accessories



### Key Commercial Data

Packing unit	1 pc
GTIN	 4 046356 690843
GTIN	4046356690843
Weight per Piece (excluding packing)	40.000 g
Custom tariff number	85362010
Country of origin	Germany

### Technical data

#### Dimensions

Height	45 mm
Width	12.3 mm
Depth	52 mm

#### Ambient conditions

# Electronic device circuit breaker - CB E1 24DC/10A S-C P - 2800928

## Technical data

### Ambient conditions

Ambient temperature (operation)	-25 °C ... 50 °C (non-condensing)
Ambient temperature (storage/transport)	-40 °C ... 70 °C
Humidity test	96 h, 95 % RH, 40 °C
Vibration (operation)	3g (In accordance with IEC 60068-2-6, Test Fc)
Degree of protection	IP30 (Actuation area)

### General

Flammability rating according to UL 94	V-0
Mounting type	on base element
Color	gray
Number of positions	1
Degree of pollution	2
Type	Male

### Electrical data

Fuse type	electronic
Rated surge voltage	0.5 kV
Operating voltage	24 V DC
	18 V DC ... 30 V DC
Nominal current $I_N$	10 A
Rated insulation voltage $U_i$	30 V (Load circuit)
Active current limitation	typ. 1.25 x $I_N$
Closed circuit current $I_0$	typ. 8 mA (When switched on)
	typ. 11 mA (With status output)
Power dissipation	1.46 W (Nominal operation)
Temperature derating	9 A (at 50 °C)
Tripping method	E (electronic)
Required backup fuse	not required, integrated failsafe element
Dielectric strength	max. 30 V DC (Load circuit)
Voltage drop	120 mV (at $I_N$ )
Shutdown time load circuit	80 ms (see time/current characteristic curve)
Undervoltage switch-off load circuit	< 14 V (typ. OFF)
	> 17 V (typ. ON)
Max. capacitive load load circuit	20000 $\mu$ F
Output voltage status output	24 V DC
Output current status output	max. 0.2 A (Short-circuit-proof)
Input voltage reset input	max. 30 V DC
Current consumption reset input	typ. 2.6 mA (at 24 V DC)

# Electronic device circuit breaker - CB E1 24DC/10A S-C P - 2800928

## Technical data

### Electrical data

Pulse length reset input	min. 20 ms
Voltage reset input	< 3 V DC (Low state)
	> 8 V DC (High state)
Auxiliary type of contact	Positive-switching signal output

### Standards and Regulations

Standards/specifications	EMV EN 61000-6-3 Interference emission
	EMV EN 61000-6-2 Noise immunity

### Environmental Product Compliance

REACH SVHC	Lead 7439-92-1
China RoHS	Environmentally Friendly Use Period = 50 years
	For details about hazardous substances go to tab "Downloads", Category "Manufacturer's declaration"

## Drawings

Application drawing

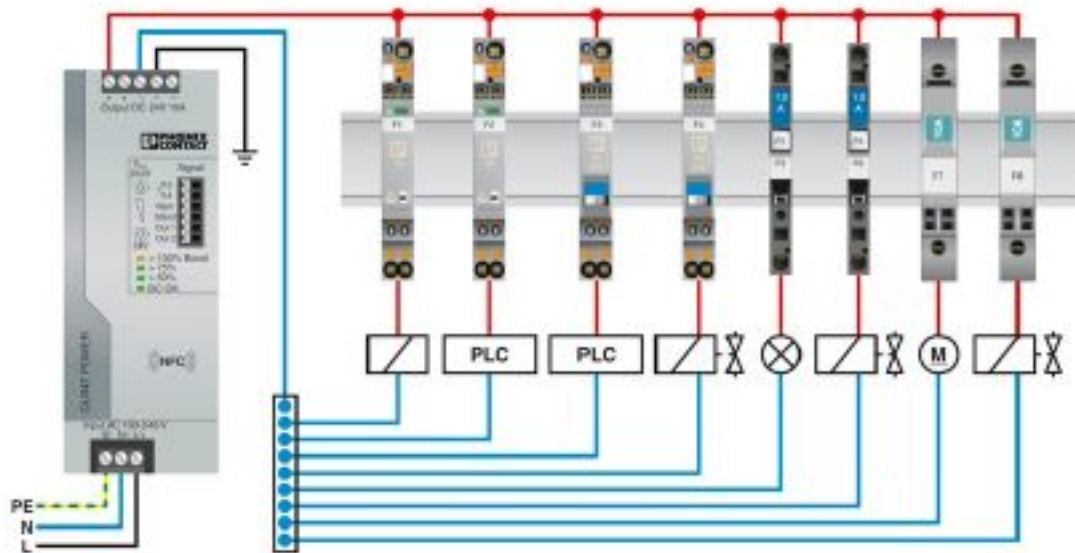

# Electronic device circuit breaker - CB E1 24DC/10A S-C P - 2800928

Circuit diagram

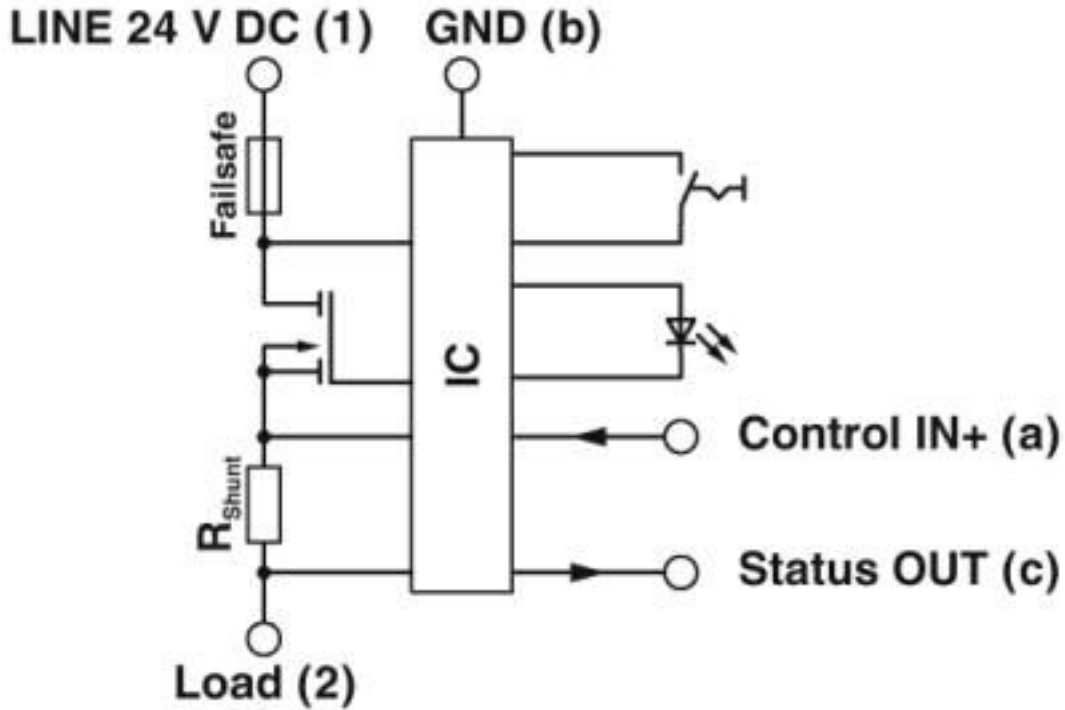

## Classifications

eCl@ss

eCl@ss 10.0.1	27140401
eCl@ss 4.0	27141100
eCl@ss 4.1	27141100
eCl@ss 5.0	27141100
eCl@ss 5.1	27141100
eCl@ss 6.0	27141100
eCl@ss 7.0	27141116
eCl@ss 8.0	27141116
eCl@ss 9.0	27141116

ETIM

ETIM 3.0	EC000899
ETIM 4.0	EC000899
ETIM 5.0	EC000899
ETIM 6.0	EC000899
ETIM 7.0	EC000899

# Electronic device circuit breaker - CB E1 24DC/10A S-C P - 2800928

## Classifications

### UNSPSC

UNSPSC 6.01	30211812
UNSPSC 7.0901	39121411
UNSPSC 11	39121411
UNSPSC 12.01	39121411
UNSPSC 13.2	39121410
UNSPSC 18.0	39121410
UNSPSC 19.0	39121410
UNSPSC 20.0	39121410
UNSPSC 21.0	39121410

## Approvals

### Approvals

#### Approvals

UL Listed / UL Recognized / cUL Listed / DNV GL / cULus Listed

#### Ex Approvals

### Approval details

UL Listed		<a href="http://database.ul.com/cgi-bin/XYV/template/LISEXT/1FRAME/index.htm">http://database.ul.com/cgi-bin/XYV/template/LISEXT/1FRAME/index.htm</a>	FILE E 140324
-----------	--	---	---------------

UL Recognized		<a href="http://database.ul.com/cgi-bin/XYV/template/LISEXT/1FRAME/index.htm">http://database.ul.com/cgi-bin/XYV/template/LISEXT/1FRAME/index.htm</a>	FILE E 317172
---------------	--	---	---------------

cUL Listed		<a href="http://database.ul.com/cgi-bin/XYV/template/LISEXT/1FRAME/index.htm">http://database.ul.com/cgi-bin/XYV/template/LISEXT/1FRAME/index.htm</a>	FILE E 140324
------------	--	---	---------------

DNV GL		<a href="https://approvalfinder.dnvgl.com/">https://approvalfinder.dnvgl.com/</a>	TAE00003KA
--------	--	---	------------

## Electronic device circuit breaker - CB E1 24DC/10A S-C P - 2800928

### Approvals

cULus Listed



### Accessories

#### Accessories

##### Bridge

Jumper - CB PT BRIDGE - 2801014



Bridge plug for bridging contacts 1 to 2 for CB base elements

Jumper - CB RC BRIDGE - 2801616



Bridge plug for bridging contacts 11 to 14 for CB base elements

##### Cutting tools

Front cutter - CUTFOX-FBS - 1212124



Cutting tool, for separating individual jumper bars from FBS ... plug-in bridges and EB ... insertion bridges

##### Jumper

## Electronic device circuit breaker - CB E1 24DC/10A S-C P - 2800928

### Accessories

Plug-in bridge - FBS 2-6 - 3030336



Plug-in bridge, pitch: 6.2 mm, width: 10.7 mm, number of positions: 2, color: red

---

Plug-in bridge - FBS 3-6 - 3030242



Plug-in bridge, pitch: 6.2 mm, width: 16.9 mm, number of positions: 3, color: red

---

Plug-in bridge - FBS 4-6 - 3030255



Plug-in bridge, pitch: 6.2 mm, width: 23.1 mm, number of positions: 4, color: red

---

Plug-in bridge - FBS 5-6 - 3030349



Plug-in bridge, pitch: 6.2 mm, width: 29.3 mm, number of positions: 5, color: red

---

Plug-in bridge - FBS 10-6 - 3030271



Plug-in bridge, pitch: 6.2 mm, width: 60.3 mm, number of positions: 10, color: red

---

## Electronic device circuit breaker - CB E1 24DC/10A S-C P - 2800928

### Accessories

Plug-in bridge - FBS 20-6 - 3030365



Plug-in bridge, pitch: 6.2 mm, width: 122.3 mm, number of positions: 20, color: red

---

Plug-in bridge - FBS 50-6 - 3032224



Plug-in bridge, pitch: 6.2 mm, width: 308.3 mm, number of positions: 50, color: red

---

### Labeled terminal marker

Zack Marker strip, flat - ZBF 12 CUS - 0825018



Zack Marker strip, flat, can be ordered: Strip, white, labeled according to customer specifications, mounting type: snap into flat marker groove, for terminal block width: 12 mm, lettering field size: 5.15 x 12.15 mm, Number of individual labels: 5

---

### Terminal marking

Zack Marker strip, flat - ZBF 12:UNBEDRUCKT - 0809735



Zack Marker strip, flat, Strip, white, unlabeled, can be labeled with: PLOTMARK, CMS-P1-PLOTTER, mounting type: snap into flat marker groove, for terminal block width: 12 mm, lettering field size: 5.15 x 12.15 mm, Number of individual labels: 5

---

### Necessary add-on products

## Electronic device circuit breaker - CB E1 24DC/10A S-C P - 2800928

### Accessories

Base element - CB 1/6-2/4 PT-BE - 2800929



Base element with push-in connection technology for CB ... device circuit breakers

---

Base element - CB 1/10-1/10 UT-BE - 2801305



Base element with screw connection technology for CB... device circuit breakers

---

---