

Temperature measuring transducer - MINI MCR-SL-PT100-LP-NC-SP - 2810395

Please be informed that the data shown in this PDF Document is generated from our Online Catalog. Please find the complete data in the user's documentation. Our General Terms of Use for Downloads are valid (<http://phoenixcontact.com/download>)



Configurable loop-powered temperature transducer for Pt 100 temperature sensors, configured via DIP switches, with spring-cage connection, not pre-configured. Replacement part: 2810308 MINI MCR-SL-PT100-LP-NC.

Your advantages

- ✓ 2, 3 or 4-wire Pt 100 sensors
- ✓ Highly-compact loop-powered temperature transducer for electrical isolation, conversion, amplification, and filtering of Pt 100 signals to create standard signals
- ✓ Does not require additional auxiliary voltage
- ✓ Error indication via diagnostic LED and analog signal
- ✓ 2-way isolation
- ✓ Temperature measuring range of -150°C to +300°C
- ✓ Supplied by an output loop
- ✓ Input signals can be configured via DIP switches



Key Commercial Data

Packing unit	1 pc
GTIN	 4 046356 142472
GTIN	4046356142472
Weight per Piece (excluding packing)	80.000 g
Custom tariff number	85437090
Country of origin	Germany

Temperature measuring transducer - MINI MCR-SL-PT100-LP-NC-SP - 2810395

Technical data

Note

Utilization restriction	EMC: class A product, see manufacturer's declaration in the download area
-------------------------	---

Dimensions

Width	6.2 mm
Height	93.1 mm
Depth	102.5 mm

Ambient conditions

Ambient temperature (operation)	-20 °C ... 65 °C
Ambient temperature (storage/transport)	-40 °C ... 85 °C
Maximum altitude	≤ 2000 m
Permissible humidity (operation)	5 % ... 95 % (non-condensing)
Degree of protection	IP20
Noise immunity	EN 61000-6-2 When being exposed to interference, there may be minimal deviations.

Input data

Configurable/programmable	Yes, unconfigured
Sensor types (RTD) that can be used	Pt 100 (IEC 60751/EN 60751)
Sensor input current	1 mA (constant)
Connection technology	2, 3, 4-wire

Output data

Number of outputs	1
Configurable/programmable	Yes, unconfigured
Current output signal	4 mA ... 20 mA
	20 mA ... 4 mA
Max. output current	23 mA (output limit)
Load/output load current output	$(U_{\text{supply}} - 12 \text{ V}) / 22 \text{ mA}$
Ripple	< 20 mV _{PP} (at 500 Ω)

Power supply

Designation	Loop-powered
Supply voltage range	12 V DC ... 30 V DC
Max. current consumption	< 4.5 mA (without signal current)
Power consumption	< 150 mW (without signal current)

Connection data

Temperature measuring transducer - MINI MCR-SL-PT100-LP-NC-SP - 2810395

Technical data

Connection data

Connection method	Spring-cage connection
Stripping length	8 mm
Conductor cross section solid	0.2 mm ² ... 2.5 mm ²
Conductor cross section flexible	0.2 mm ² ... 2.5 mm ²
Conductor cross section AWG	24 ... 12

General

Transmission error in the set measuring range	((90 K / set measuring range [K]) + 0.05)%
Transmission error in the full measuring range	≤ 0,25 %
Maximum temperature coefficient	< 0.02 %/K
Linearity error	< 0.05 % (for full measuring range)
Electrical isolation	Basic insulation according to EN 61010
Overvoltage category	II
Degree of pollution	2
Rated insulation voltage	30 V AC
Test voltage, input/output/supply	1.5 kV (50 Hz, 1 min.)
Electromagnetic compatibility	Conformance with EMC directive
Noise emission	EN 61000-6-4
Noise immunity	EN 61000-6-2 When being exposed to interference, there may be minimal deviations.
Color	green
Housing material	PBT
Mounting position	any
Conformance	CE-compliant
ATEX	# II 3 G Ex nA IIC T4 Gc X
UL, USA/Canada	UL 508 Recognized
	Class I, Div. 2, Groups A, B, C, D T4
Fire protection for rail vehicles (DIN EN 45545-2) R22	HL 1 - HL 2
Fire protection for rail vehicles (DIN EN 45545-2) R23	HL 1 - HL 2
Fire protection for rail vehicles (DIN EN 45545-2) R24	HL 1 - HL 2

EMC data

Designation	Electromagnetic RF field
Standards/regulations	EN 61000-4-3
Typical deviation from the measuring range final value	5 %
Designation	Fast transients (burst)
Standards/regulations	EN 61000-4-4

Temperature measuring transducer - MINI MCR-SL-PT100-LP-NC-SP - 2810395

Technical data

EMC data

Typical deviation from the measuring range final value	5 %
Designation	Conducted interferences
Standards/regulations	EN 61000-4-6
Typical deviation from the measuring range final value	5 %

Standards and Regulations

Electromagnetic compatibility	Conformance with EMC directive
Noise emission	EN 61000-6-4
Connection in acc. with standard	CUL
Standards/regulations	EN 61000-4-2
Designation	Electromagnetic RF field
Standards/regulations	EN 61000-4-3
	EN 61000-4-4
	EN 61000-4-5
Designation	Conducted interferences
Standards/regulations	EN 61000-4-6
Electrical isolation	Basic insulation according to EN 61010
Conformance	CE-compliant
ATEX	# II 3 G Ex nA IIC T4 Gc X
UL, USA/Canada	UL 508 Recognized
	Class I, Div. 2, Groups A, B, C, D T4

Environmental Product Compliance

REACH SVHC	Lead 7439-92-1
China RoHS	Environmentally Friendly Use Period = 50 years
	For details about hazardous substances go to tab "Downloads", Category "Manufacturer's declaration"

Drawings

Temperature measuring transducer - MINI MCR-SL-PT100-LP-NC-SP - 2810395

Application drawing

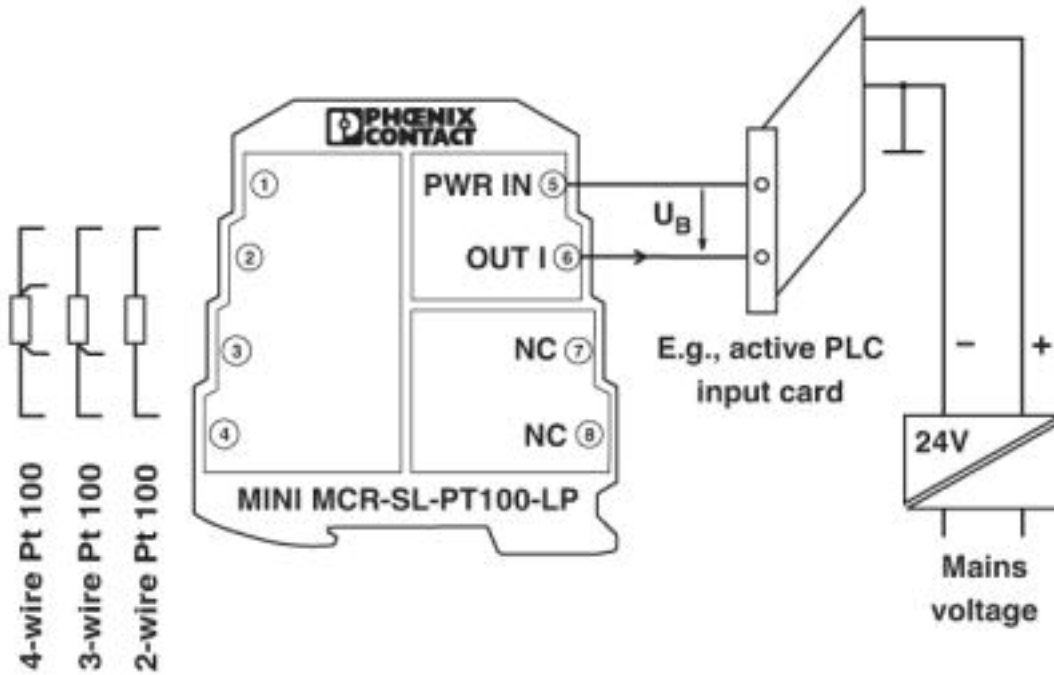

Temperature measuring transducer - MINI MCR-SL-PT100-LP-NC-SP - 2810395

Block diagram

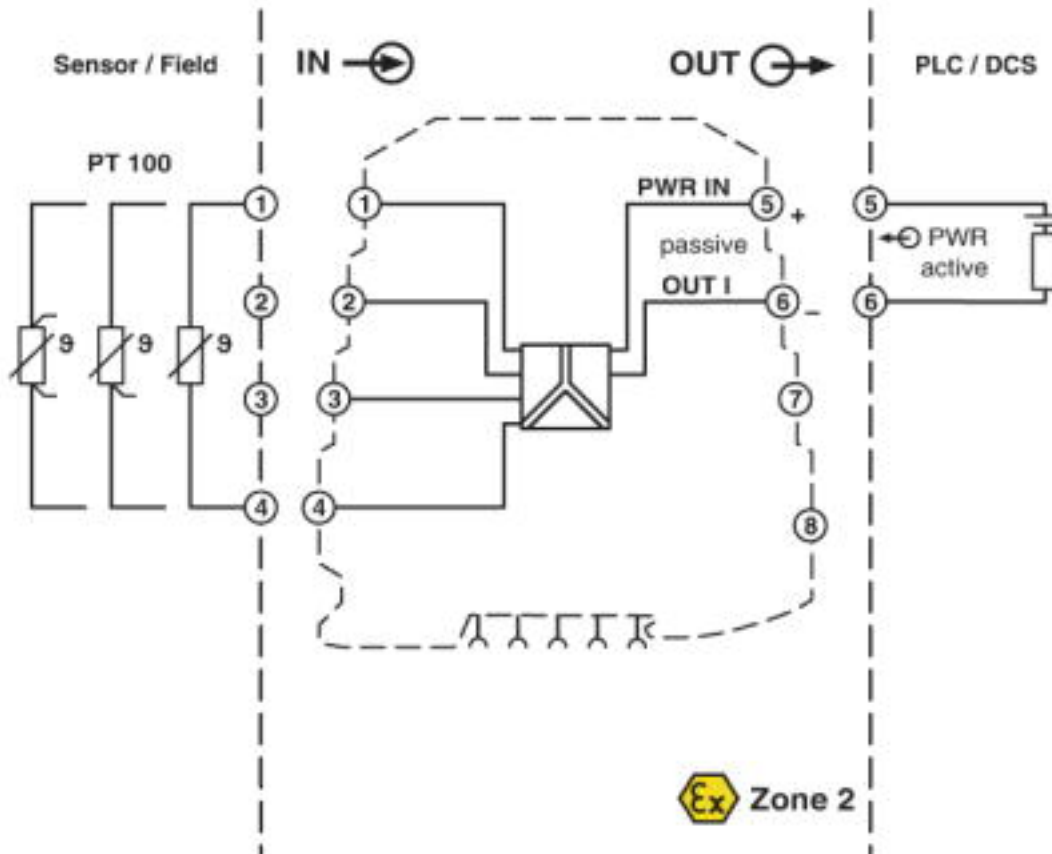

Temperature measuring transducer - MINI MCR-SL-PT100-LP-NC-SP - 2810395

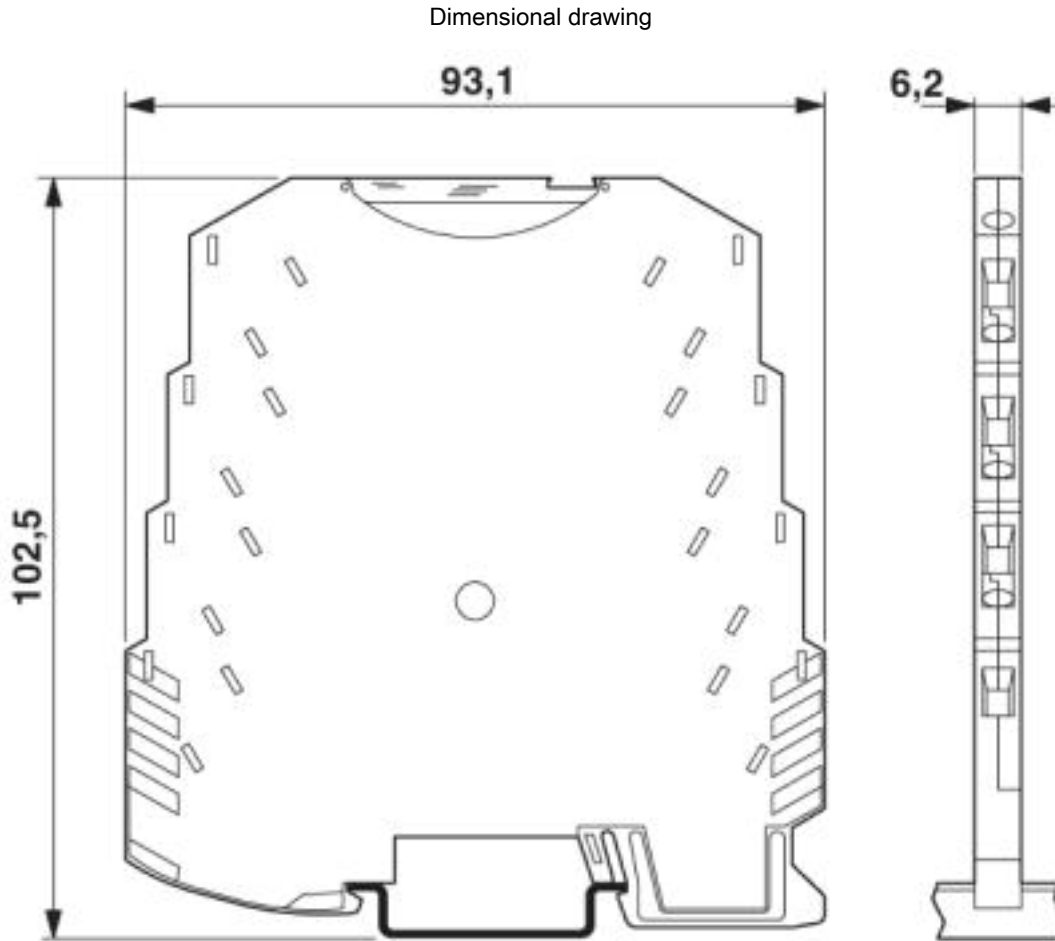

Classifications

eCl@ss

eCl@ss 4.0	27200200
eCl@ss 4.1	27200200
eCl@ss 5.0	27200200
eCl@ss 5.1	27200200
eCl@ss 6.0	27200200
eCl@ss 7.0	27200206
eCl@ss 8.0	27200206
eCl@ss 9.0	27210129

Temperature measuring transducer - MINI MCR-SL-PT100-LP-NC-SP - 2810395

Classifications

ETIM

ETIM 2.0	EC001446
ETIM 3.0	EC001446
ETIM 4.0	EC001446
ETIM 5.0	EC001446
ETIM 6.0	EC002919
ETIM 7.0	EC002919

UNSPSC

UNSPSC 6.01	30211506
UNSPSC 7.0901	39121008
UNSPSC 11	39121008
UNSPSC 12.01	39121008
UNSPSC 13.2	41112105
UNSPSC 19.0	41112105

Approvals

Approvals

Approvals

UL Recognized / cUL Recognized / cULus Recognized

Ex Approvals

ATEX / UL Listed / cUL Listed / EAC Ex / cULus Listed

Approval details

UL Recognized		http://database.ul.com/cgi-bin/XYV/template/LISEXT/1FRAME/index.htm	FILE E 238705
---------------	--	---	---------------

cUL Recognized		http://database.ul.com/cgi-bin/XYV/template/LISEXT/1FRAME/index.htm	FILE E 238705
----------------	--	---	---------------

Temperature measuring transducer - MINI MCR-SL-PT100-LP-NC-SP - 2810395

Approvals

cULus Recognized

