

## Type 2 surge arrester - VAL-MS 60/FM - 2868033

Please be informed that the data shown in this PDF Document is generated from our Online Catalog. Please find the complete data in the user's documentation. Our General Terms of Use for Downloads are valid (<http://phoenixcontact.com/download>)



Surge arrester consisting of base element with remote indicator contact and protective connector with high-capacity varistor, for mounting on NS 35/7.5, 1-channel

### Product Features

- Single-channel, DIN-rail mountable protective devices
- Disconnect device on each individual plug
- Base element with/without floating remote indication contact
- Consists of base element and plug
- Mechanical coding of all slots
- Optical, mechanical status indication for the individual arresters



### Key Commercial Data

Packing unit	1 pc
Weight per Piece (excluding packing)	125.33 g
Custom tariff number	85363010
Country of origin	Germany

### Technical data

#### Dimensions

Height	97 mm
Width	17.6 mm
Depth	65.5 mm
Horizontal pitch	1 Div.

#### Ambient conditions

Degree of protection	IP20 (only when all terminal points are used)
----------------------	---

## Type 2 surge arrester - VAL-MS 60/FM - 2868033

### Technical data

#### Ambient conditions

Ambient temperature (operation)	-40 °C ... 80 °C
Ambient temperature (storage/transport)	-40 °C ... 80 °C
Altitude	≤ 2000 m (amsl (above mean sea level))
Permissible humidity (operation)	5 % ... 95 %
Shock (operation)	25g (half sinus / 11 ms / 3x ±X, ±Y, ±Z)
Vibration (operation)	5g (10 ... 500 Hz / 2.5 h / X, Y, Z)

#### General

Standards/specifications	IEC 61643-11 2011
	EN 61643-11 2012
IEC test classification	II
	T2
EN type	T2
IEC power supply system	TN
Number of ports	One
SPD design	Voltage-limiting type
Mode of protection	L-PEN
Mounting type	DIN rail: 35 mm
Color	jet black RAL 9005
Housing material	PA 6.6
	PBT
Degree of pollution	2
Flammability rating according to UL 94	V-0
Type	DIN rail module, two-section, divisible
Number of positions	1
Surge protection fault message	Optical, remote indicator contact

#### Protective circuit

Nominal voltage $U_N$	60 V AC (TN)
	60 V DC
	-48 V DC (RRH)
Nominal frequency $f_N$	50 Hz (60 Hz)
Maximum continuous voltage $U_C$	75 V AC
Rated load current $I_L$	80 A
Residual current $I_{PE}$	≤ 0.45 mA
Standby power consumption $P_C$	≤ 35 mVA
Nominal discharge current $I_n$ (8/20) $\mu$ s	15 kA
Maximum discharge current $I_{max}$ (8/20) $\mu$ s	40 kA

## Type 2 surge arrester - VAL-MS 60/FM - 2868033

### Technical data

#### Protective circuit

Short-circuit current rating $I_{SCCR}$	25 kA
Voltage protection level $U_p$	$\leq 0.55$ kV
Residual voltage $U_{res}$	$\leq 0.55$ kV (at $I_n$ )
	$\leq 0.425$ kV (at 10 kA)
	$\leq 0.325$ kV (at 5 kA)
	$\leq 0.275$ kV (at 3 kA)
TOV behavior at $U_T$	100 V AC (5 s / withstand mode)
Response time $t_A$	$\leq 25$ ns
Max. backup fuse with branch wiring	125 A AC (gG)
	50 A DC (gG)
Max. backup fuse with V-type through wiring	80 A AC (gG)

#### Indicator/remote signaling

Connection name	Remote fault indicator contact
Switching function	PDT contact
Operating voltage	5 V AC ... 250 V AC
	30 V DC
Operating current	5 mA AC ... 1 A
	1 A
Connection method	Screw connection
Screw thread	M2
Tightening torque	0.25 Nm
Stripping length	7 mm
Conductor cross section flexible	0.14 mm <sup>2</sup> ... 1.5 mm <sup>2</sup>
Conductor cross section solid	0.14 mm <sup>2</sup> ... 1.5 mm <sup>2</sup>
Conductor cross section AWG	28 ... 16

#### Connection data

Connection method	Screw connection
Conductor cross section flexible	1.5 mm <sup>2</sup> ... 25 mm <sup>2</sup>
Conductor cross section solid	1.5 mm <sup>2</sup> ... 35 mm <sup>2</sup>
Conductor cross section AWG	15 ... 2
Screw thread	M5
Tightening torque	4.5 Nm
Stripping length	16 mm

#### UL specifications

SPD Type	4CA
Maximum continuous operating voltage MCOV (L-N)	75 V AC

## Type 2 surge arrester - VAL-MS 60/FM - 2868033

### Technical data

#### UL specifications

Maximum continuous operating voltage MCOV (L+) - (L-)	100 V DC
Nom. voltage	60 V AC
Nominal voltage	60 V DC
Mode of protection	L-N
	(L+) - (L-)
Power distribution system	1
Nominal frequency	50/60 Hz
Measured limiting voltage MLV (L-N)	630 V
Measured limiting voltage MLV (L+) - (L-)	810 V
Nominal discharge current $I_n$ (L-N)	10 kA
Nominal discharge current $I_n$ (L+) - (L-)	10 kA

#### UL indicator/remote signaling

Operating voltage	125 V AC
Operating current	1 A
Tightening torque	4 lb <sub>r</sub> -in.
Conductor cross section AWG	30 ... 14

#### UL connection data

Conductor cross section AWG	10 ... 2
Tightening torque	30 lb <sub>r</sub> -in.

### Classifications

#### eCl@ss

eCl@ss 4.0	27140201
eCl@ss 4.1	27130801
eCl@ss 5.0	27130801
eCl@ss 5.1	27130801
eCl@ss 6.0	27130805
eCl@ss 7.0	27130805
eCl@ss 8.0	27130805
eCl@ss 9.0	27130805

#### ETIM

ETIM 2.0	EC000941
ETIM 3.0	EC000941
ETIM 4.0	EC000941

# Type 2 surge arrester - VAL-MS 60/FM - 2868033

## Classifications

### ETIM

ETIM 5.0	EC000941
----------	----------

### UNSPSC

UNSPSC 6.01	30212010
UNSPSC 7.0901	39121610
UNSPSC 11	39121610
UNSPSC 12.01	39121610
UNSPSC 13.2	39121620

## Approvals

### Approvals

---

#### Approvals

UL Recognized / KEMA-KEUR / cUL Recognized / CSA / ÖVE / CCA / IECCE CB Scheme / EAC / cULus Recognized

---

#### Ex Approvals

---

#### Approvals submitted

---

### Approval details

UL Recognized
---------------

KEMA-KEUR
-----------

cUL Recognized
----------------

CSA
-----

# Type 2 surge arrester - VAL-MS 60/FM - 2868033

## Approvals



CCA

IECEE CB Scheme

EAC

cULus Recognized

## Drawings

Dimensional drawing

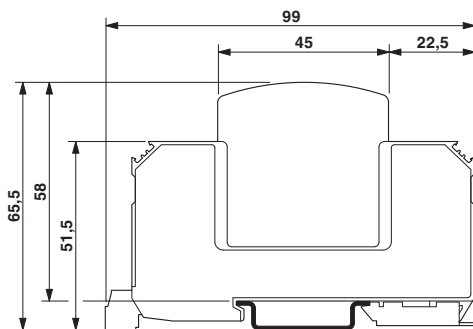

Circuit diagram

