

Type 2 surge protection base element - VAL-MS 75X350/3EQ/ FM - 2905251

Please be informed that the data shown in this PDF Document is generated from our Online Catalog. Please find the complete data in the user's documentation. Our General Terms of Use for Downloads are valid (<http://phoenixcontact.com/download>)



Base element for type 2 arresters of the VALVETRAB MS product range, with remote indication contact. Version for 3-mode protection of 2-wire signals.

Why buy this product

- Versions with and without floating remote indication contact
- 3-Mode equalizer protection
- Mechanical coding of all slots
- Optical, mechanical status indication for the individual arresters
- Type 2 consistent plug-in surge arresters

RoHS

Key Commercial Data

Packing unit	1 STK
GTIN	 4 046356 958554
GTIN	4046356958554
Weight per Piece (excluding packing)	300.000 g
Country of origin	Germany

Technical data

Note

Trade restriction	The products are offered exclusively for export outside the EU and the European Economic Area.
-------------------	--

Dimensions

Height	99 mm
Width	53.4 mm

Type 2 surge protection base element - VAL-MS 75X350/3EQ/ FM - 2905251

Technical data

Dimensions

Depth	65.5 mm
Horizontal pitch	3 Div.

Ambient conditions

Degree of protection	IP20
Ambient temperature (operation)	-40 °C ... 80 °C
Permissible humidity (operation)	5 % ... 95 %
Shock (operation)	25g
Vibration (operation)	5g

General

Housing material	PBT / PA
Flammability rating according to UL 94	V0
Color	black
Standards for clearances and creepage distances	EN 60664-1
	EN 61643-1
Mounting type	DIN rail: 35 mm
Design	DIN rail module, two-section, divisible
Number of positions	3
Surge protection fault message	Optical, remote indicator contact
Direction of action	(L+)-PE & (L-)-PE & (L+)-(L-)

Protective circuit

IEC test classification	II
	T2
Nominal voltage U_N	5 V AC ... 48 V AC
Maximum continuous operating voltage U_C	60 V
	60 V
Maximum continuous operating voltage U_C (L-PE)	230 V
Nominal frequency f_N	50 Hz (60 Hz)
Rated load current I_L	80 A (Serial through wiring at 16 mm ²)
Residual current I_{PE}	≤ 5 μA
Max. discharge current I_{max} (8/20) μs	20 kA
Max. discharge current I_{max} (8/20) μs maximum (L-N)	20 kA
Max. discharge current I_{max} (8/20) μs maximum (L-PE)	20 kA
Max. discharge current I_{max} (8/20) μs maximum (N-PE)	20 kA
Nominal discharge current I_n (8/20) μs	10 kA

Type 2 surge protection base element - VAL-MS 75X350/3EQ/ FM - 2905251

Technical data

Protective circuit

Nominal discharge current I_n (8/20) μ s (L-PE)	10 kA
Voltage protection level U_p	≤ 700 V
Voltage protection level U_p (L-N)	≤ 1.4 kV
Voltage protection level U_p (L-PE)	≤ 1500 V
Voltage protection level U_p (N-PE)	≤ 1.5 kV
Voltage protection level U_p (L+) - (L-)	≤ 700 V
Voltage protection level U_p (L+/L-) - PE	≤ 1500 V
Response time t_A	≤ 25 ns
Max. backup fuse with branch wiring	200 A (gL / gG)
Max. backup fuse with V-type through wiring	80 A (gL / gG)
Short-circuit resistance I_p with max. backup fuse (effective)	25 kA
Short-circuit current rating I_{SCCR}	10 kA (L-L)

Connection, protective circuit

Connection method	Screw connection
Connection method IN	Biconnect screw terminal block
Connection method OUT	Biconnect screw terminal block
Connection technology	Biconnect terminal block
Screw thread	M5
Tightening torque	26.5 lb _f -in. ... 30 lb _f -in. (UL)
Stripping length	16 mm
Conductor cross section flexible min.	1.5 mm ²
Conductor cross section flexible max.	25 mm ²
Conductor cross section solid min.	1.5 mm ²
Conductor cross section solid max.	35 mm ²
Conductor cross section AWG min.	15
Conductor cross section AWG max.	2
Conductor cross section AWG	10 ... 2 (UL)

Remote indication contact

Connection name	Remote fault indicator contact
Switching function	PDT, 1-pos.
Connection method	MC 1,5/3
Screw thread	M2
Tightening torque	0.25 Nm
	4 lb _f -in. (UL)

Type 2 surge protection base element - VAL-MS 75X350/3EQ/ FM - 2905251

Technical data

Remote indication contact

Stripping length	7 mm
Conductor cross section flexible min.	0.14 mm ²
Conductor cross section flexible max.	1.5 mm ²
Conductor cross section solid min.	0.14 mm ²
Conductor cross section solid max.	1.5 mm ²
Conductor cross section AWG min.	28
Conductor cross section AWG max.	16
Conductor cross section AWG	30 ... 14 (UL)
Maximum operating voltage U _{max} AC	250 V AC
Maximum operating voltage U _{max} DC	30 V DC
Max. operating current I _{max}	1.5 A AC (250 V AC)
	1.5 A DC (125 V AC)
	1.5 A DC (30 V DC)

Standards and Regulations

Standards/regulations	IEC 61643-11
	EN 61643-11
	IEC 61643-11
	EN 61643-11

Drawings

Circuit diagram

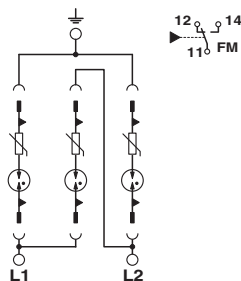

Dimensional drawing

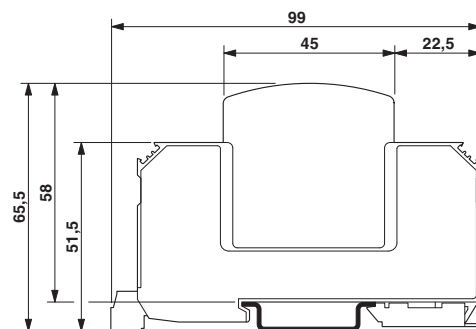

Type 2 surge protection base element - VAL-MS 75X350/3EQ/ FM - 2905251

Classifications

eCl@ss

eCl@ss 5.1	27130801
eCl@ss 6.0	27130805

Phoenix Contact 2017 © - all rights reserved
<http://www.phoenixcontact.com>