

## Electronic device circuit breaker - ECP-E 10A - 0901002

Please be informed that the data shown in this PDF Document is generated from our Online Catalog. Please find the complete data in the user's documentation. Our General Terms of Use for Downloads are valid (<http://phoenixcontact.com/download>)



Electronic device circuit breaker, Number of positions: 1, Connection method: Screw connection, Width: 12.5 mm, Fuse type: Electronic, Fuse type: Automatic device, Mounting type: On base element, Color: black

### Why buy this product

- Can be plugged onto TMCP SOCKET M base
- Design width of just 12.5 mm
- The operating or error state is indicated by a multi-color LED as well as an integrated status output (12)

### Key Commercial Data

Packing unit	5 STK
GTIN	 4 046356 103749

### Technical data

#### General

Installation instructions	When mounted in rows without convection cooling, the nominal device current should only be led to a maximum of 80% due to the thermal effect during continuous operation (100% operating factor). Special precautionary measures must be taken in systems or machines, to prevent components from restarting (e.g., use of a safety PLC). Parallel connection of multiple circuit breakers is not permitted.
Mounting type	On base element
Color	black
Number of positions	1
Overvoltage category	II
Insulating material	PA66/6
Flammability rating according to UL 94	V0

#### Electrical data

Fuse	Electronic
Fuse type	Automatic device
Rated surge voltage	0.5 kV
Operating voltage	24 V DC
	18 V DC ... 32 V DC
Nominal current $I_N$	10 A

# Electronic device circuit breaker - ECP-E 10A - 0901002

## Technical data

### Electrical data

Required backup fuse	not required, integrated failsafe element
Dielectric strength	max. 32 V DC (Load circuit)
Degree of pollution	2
Overvoltage category	II
Insulating material group	I
Switching capacity I <sub>CN</sub>	Active current limitation
Closed-circuit current range I <sub>0</sub>	typ. 25 mA ±5 mA (When switched on)

### Dimensions

Height	60 mm
Width	12.5 mm
Depth	70 mm
Height NS 35/7,5	144 mm
Height NS 35/15	151.5 mm
Complete module height	115 mm
Complete module width	38 mm
Complete module depth	112.5 mm

### Ambient conditions

Degree of protection	IP30 (Actuation area)
Ambient temperature (operation)	0 °C ... 50 °C (non-condensing)

### Connection data

Connection method	Screw connection
-------------------	------------------

### Standards and Regulations

Standards/specifications	UL 2367
	UL 508
	CSA 22.2 No. 14

## Classifications

### eCl@ss

eCl@ss 4.0	27141116
eCl@ss 4.1	27141116
eCl@ss 5.0	27141116
eCl@ss 5.1	27141116
eCl@ss 6.0	27141116
eCl@ss 7.0	27141116
eCl@ss 8.0	27141116

### ETIM

ETIM 2.0	EC000899
----------	----------

# Electronic device circuit breaker - ECP-E 10A - 0901002

## Classifications

### ETIM

ETIM 3.0	EC000899
ETIM 4.0	EC000899
ETIM 5.0	EC000899

### UNSPSC

UNSPSC 6.01	30211812
UNSPSC 7.0901	39121411
UNSPSC 11	39121411
UNSPSC 12.01	39121411
UNSPSC 13.2	39121411

## Approvals

### Approvals

---

Approvals

UL Recognized / EAC

---

Ex Approvals

CSA

---

Approvals submitted

---

### Approval details

UL Recognized 
---

EAC
-----

## Drawings

# Electronic device circuit breaker - ECP-E 10A - 0901002

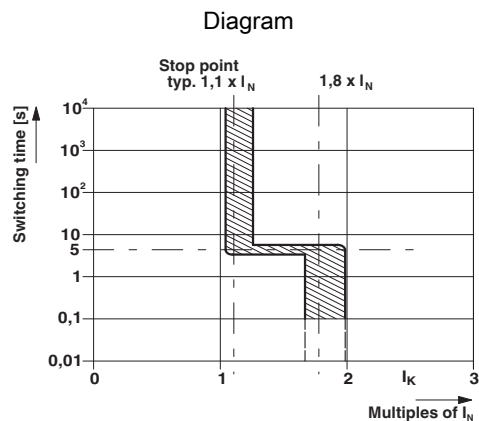
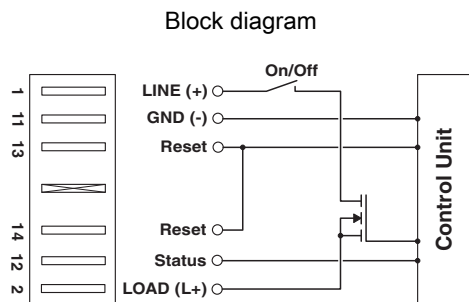

Phoenix Contact 2016 © - all rights reserved  
<http://www.phoenixcontact.com>

PHOENIX CONTACT GmbH & Co. KG  
Flachsmarktstr. 8  
32825 Blomberg  
Germany  
Tel. +49 5235 300  
Fax +49 5235 3 41200  
<http://www.phoenixcontact.com>