

WIRELESS ACCESSORIES

Accessories for wireless transmission systems

INTERFACE

Data sheet
101580_en_05

© PHOENIX CONTACT 2010-04-27

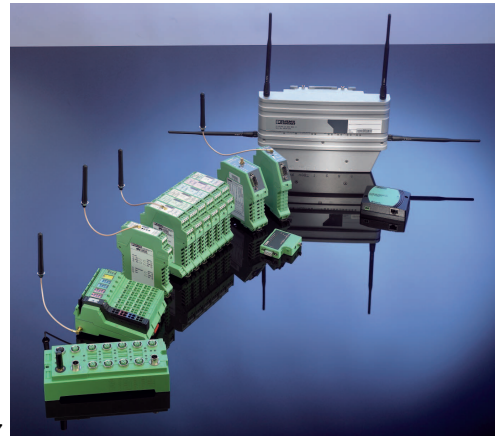

1 Description

The aim of Phoenix Contact wireless transmission solutions is to provide users with the simplest possible access to the wireless transmission medium.

This explanation of the complex area of antenna technology will therefore be kept as simple as possible. However, in order to build reliable systems, a few basic properties of antenna technology must be taken into account.



NOTE:

Make sure that the maximum permissible emitted power for your country is not exceeded (Europe: 20 dBm, maximum).



Make sure you always use the latest documentation.
It can be downloaded at www.phoenixcontact.net/catalog.



This data sheet is valid for all products listed on page 3.

2 Table of contents

1	Description.....	1
2	Table of contents	2
3	Ordering data.....	3
4	Antenna alignment.....	5
5	Antennas and accessories for 2.4 GHz and 5 GHz.....	6
5.1	Omnidirectional antennas.....	6
5.2	Panel antennas	14
5.3	Type EF393 antenna extension cables	19
5.4	Type EF142 antenna extension cables	19
5.5	Adapter cables (pigtailed)	20
5.6	Adapter cable with HF gasket sleeve	21
5.7	2.4 GHz surge protection adapters.....	22
5.8	5 GHz surge protection adapters.....	22
5.9	Adapters.....	23
5.10	Vulcanizing sealing tape.....	23
5.11	Antenna splitter sets.....	24
6	Antennas and accessories for GSM/UMTS	25
6.1	GSM/UMTS antennas	25
6.2	GSM/UMTS antenna cables.....	27
6.3	Adapter	27
6.4	Vulcanizing sealing tape.....	28
7	Selection guide and application examples.....	29
7.1	Pigtail selection tables.....	29
7.2	Application examples for the RAD-ISM-2400-SPL-4-SMA 4-way antenna splitter set.....	34
7.3	Application examples for the RAD-ISM-2400-SPL-2-SMA 2-way antenna splitter set.....	35

3 Ordering data

Antennas

Description	Type	Order No.	Pcs./Pkt.
Omnidirectional antenna, 2 dBi gain, MCX connection	RAD-ISM-2400-ANT-OMNI-2-1	2867461	1
Omnidirectional antenna with protection against vandalism, 3 dBi gain, MCX connection	RAD-ISM-2400-ANT-VAN-3-1-MCX	2885702	1
Omnidirectional antenna with protection against vandalism, 3 dBi gain, SMA connection	RAD-ISM-2400-ANT-VAN-3-0-SMA	2885867	1
Dual band omnidirectional antenna designed for the food industry, 3 dBi gain, SMA connection	RAD-ISM-2459-ANT-FOOD-6-0	2692526	1
Assembly material for wall mounting omnidirectional antennas with protection against vandalism	RAD-ANT-VAN-MKT	2885870	1
Omnidirectional antenna, 5 dBi gain, SMA connection	RAD-ISM-2400-ANT-OMNI-5-0	2884923	1
Omnidirectional antenna, 6 dBi gain, N connection	RAD-ISM-2400-ANT-OMNI-6-0	2885919	1
Omnidirectional antenna, 9 dBi gain, N connection	RAD-ISM-2400-ANT-OMNI-9-0	2867623	1
Panel antenna, 8 dBi gain, SMA connection	RAD-ISM-2400-ANT-PAN-8-0	2867610	1
Panel antenna, circular, 8 dBi gain, SMA connection	RAD-ISM-2400-ANT-CIR-8-0	2884936	1
Parabolic antenna, 19 dBi gain, N connection	RAD-ISM-2400-ANT-PAR 19-0	2867885	1
Antennas for GSM/UMTS			
GSM quad band omnidirectional antenna, 1 dBi gain, SMA connection	PSI-GSM-QB-ANT	2313135	1
GSM/UMTS quad band omnidirectional antenna, 1 dBi gain, SMA connection	PSI-GSM/UMTS-QB-ANT	2313371	1
GSM quad band omnidirectional antenna, 1 dBi gain, SMA connection	PSI-GSM-STUB-ANT	2313342	1
GSM/UMTS omnidirectional antenna, 2 dBi gain, 5 m antenna cable with SMA circular connector	PSI-GSM/UMTS-ANT-OMNI-2-5	2900982	1

Antenna cables

Description	Type	Order No.	Pcs./Pkt.
Antenna cable for outdoor use, N (male connector) connection at both ends			
3 m length	RAD-CAB-EF393-3M	2867649	1
5 m length	RAD-CAB-EF393-5M	2867652	1
10 m length	RAD-CAB-EF393-10M	2867665	1
15 m length	RAD-CAB-EF393-15M	2885634	1
Antenna cable for indoor use, SMA (male connector) connection at both ends			
3 m length	RAD-CAB-EF142-3M	2884512	1
5 m length	RAD-CAB-EF142-5M	2884525	1
Antenna cables for GSM/UMTS			
Antenna cable for indoor and outdoor use, SMA (male connector) ↔ SMA (female connector) connection			
5 m length	PSI-CAB-GSM/UMTS-5M	2900980	1
10 m length	PSI-CAB-GSM/UMTS-10M	2900981	1

Pigtails

Description	Type	Order No.	Pcs./Pkt.
Pigtails (adapter cables)			
MCX (male connector) ↔ SMA (male connector) 100 cm	RAD-PIG-EF316-MCX-SMA	2867678	1
MCX (male connector) ↔ N (male connector) 50 cm	RAD-PIG-EF316-MCX-N	2867681	1
N (female connector) ↔ SMA (male connector) 30 cm	RAD-PIG-EF316-N-SMA	2867694	1
N (male connector) ↔ N (female connector) 50 cm	RAD-PIG-EF316-N-N	2867704	1
SMA (male connector) ↔ SMA (male connector) 50 cm	RAD-PIG-EF316-SMA-SMA	2885618	1
SMA (male connector) ↔ SMA (male connector) 50 cm, with HF gasket sleeve	RAD-PIG-EF142-PIPE	2885922	1

WIRELESS ACCESSORIES

Surge protection adapters

Description	Type	Order No.	Pcs./Pkt.
N (female connector) ↔ N (female connector) surge protection adapter	CN-LAMBDA/4-2.0-BB	2818863	1
N (male connector) ↔ N (female connector) surge protection adapter	CN-LAMBDA/4-2.0-SB	2818876	1
N (female connector) ↔ N (female connector) surge protection adapter	CN-LAMBDA/4-2.0-BB	2838490	1
N (male connector) ↔ N (female connector) surge protection adapter	CN-LAMBDA/4-2.0-SB	2800023	1

Adapters

Description	Type	Order No.	Pcs./Pkt.
N (female connector) ↔ N (female connector) adapter	RAD-ADP-N/F-N/F	2867843	1
SMA (female connector) ↔ SMA (female connector) adapter	RAD-ADP-SMA/F-SMA/F	2884541	1
RSMA (female connector) ↔ SMA (female connector) adapter	RAD-ADP-RSMA/F-SMA/F	2884538	1
N (male connector) ↔ SMA (female connector) adapter	RAD-ADP-N/M-SMA/F	2917036	1
N (male connector) ↔ SMA (female connector) adapter	RAD-ADP-SMA/F-SMA/M-90	2917324	1

Sealing tape

Description	Type	Order No.	Pcs./Pkt.
Vulcanizing sealing tape	RAD-TAPE-SV-25-10	2885812	1

Antenna splitter sets

Description	Type	Order No.	Pcs./Pkt.
Antenna splitter set, 4-way, comprising 1 antenna splitter, 2 termination resistors, and 1 adapter	RAD-ISM-2400-SPL-4-SMA	2867856	1
Antenna splitter set, 2-way, comprising 1 antenna splitter, 1 adapter, and 4 strips of vulcanizing sealing tape	RAD-ISM-2400-SPL-2-SMA	2885595	1

4 Antenna alignment

When installing two antennas, it is generally desirable to have a line of sight between them wherever possible, as any obstacles between the antennas will adversely affect the connection.

The Fresnel zone, which extends around the direct connecting line between transmitting and receiving antennas should also be taken into account. If this zone is disturbed by any obstacles or the terrain, this will adversely affect the wireless connection.

Figure 1 illustrates an ideal installation with undisturbed connection.

In Figure 2, the Fresnel zone is adversely affected by the terrain. With the antenna masts at this low level, although there is still a line of sight, the Fresnel zone is not completely clear.

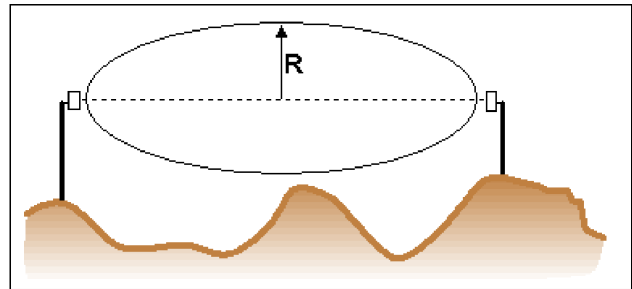

Figure 1 Ideal antenna installation

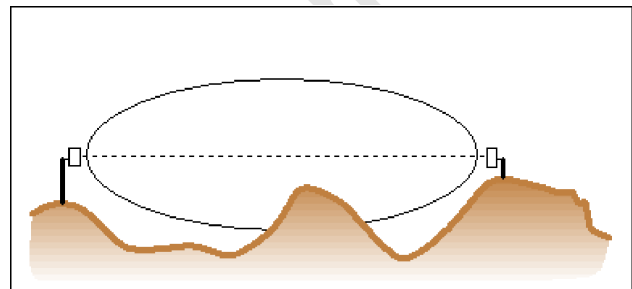

Figure 2 Fresnel zone adversely affected by the terrain

In Figure 3, the connection is attenuated by obstacles in the Fresnel zone, even though there is a line of sight.

The radius of the Fresnel zone depends on the transmission frequency and the distance between the transmitting and receiving antennas.

The radius R corresponds to the minimum height of the antenna mast (if the terrain is level). For a 2.4 GHz system, the mast height R/m , depending on the distance to be covered D/m , is given in the characteristic curve in Figure 4.

Example (Figure 4):

For a distance of 100 m, the antenna should be installed at a minimum height of 1.80 m to provide a clear Fresnel zone.

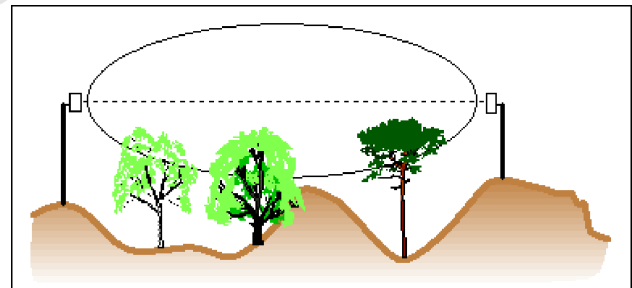

Figure 3 Fresnel zone adversely affected by obstacles

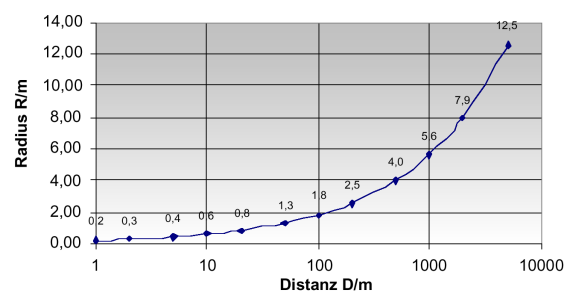

Figure 4 Radius R of the Fresnel zone over distance D

5 Antennas and accessories for 2.4 GHz and 5 GHz

5.1 Omnidirectional antennas

Omnidirectional antennas, also known as rod or omni antennas (Figure 5), are usually used if the position between the transmitter and receiver can change, i.e., for moving applications, or for example for creating multiple receiver systems where the transmitter sends the signal in several directions. The use of omnidirectional antennas is also recommended for applications with **no line of sight** because the signal then travels from the transmitter to the receiver via reflections, and their path and direction cannot be predicted.

The ideal installation location is the top of a mast or on a control cabinet, so that the antenna has the greatest possible free space in all directions.

Unfortunately it is not always possible to mount the antenna in these locations. If an omnidirectional antenna is mounted on the side of a mast, specific measurements and distances must be observed.

The mast or control cabinet (usually made from a conductive material) also affects the directional characteristics of the antenna. Both the mast diameter and the distance of the antenna from the mast influence the resulting directional characteristics.

An omnidirectional antenna that is mounted on the top of a mast or on a control cabinet usually has almost uniform directional characteristics over 360° on the horizontal plane (Figure 6).

If the same antenna is mounted on the side of an aluminum or steel mast or control cabinet, the directional characteristics may change considerably depending on the mast diameter **D** and the distance between the mast and antenna **C**. The two examples given here are for a 2.4 GHz system:

In Figure 7 (1), the omnidirectional antenna acts as an antenna with a preferred direction.

In Figure 7 (2), the range is also considerably shorter on the side facing away from the mast. This type of installation could have an unexpectedly poor result.

Wall mounting must be avoided at all costs, as the wall has an extremely negative effect on the properties of the antenna.

Key for Figure 7:

	1	2
A	Antenna	Antenna
B	Mast (diameter D = 5 cm)	Mast (diameter D = 5 cm)
C	Antenna bracket (C = 3 cm)	Antenna bracket (C = 6 cm)



Figure 5 Omnidirectional antennas

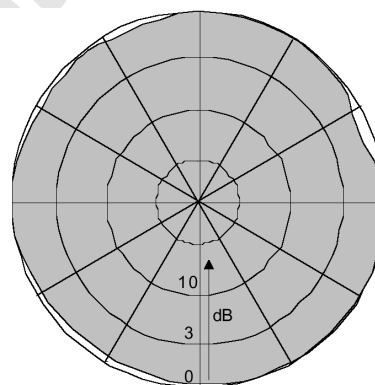

Figure 6 Uniform directional characteristics

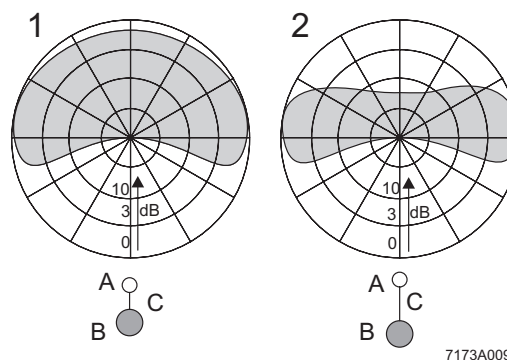

Figure 7 Antenna with preferred direction (1) and antenna with range that is considerably shorter on the side facing away from the mast (2)

WIRELESS ACCESSORIES

Technical data for the RAD-ISM-2400-ANT-OMNI-2-1 omnidirectional antenna (Order No. 2867461)

Frequency range	2.4 GHz ... 2.5 GHz
Ambient temperature range (operation)	-20°C ... +65°C
Ambient temperature range (storage)	-30°C ... +75°C
Degree of protection	IP65
Impedance	50 Ω
Gain	2 dBi
Cable length	1.5 m
Connection	MCX (male connector)
Polarization	Linear, vertical
Apex angle, horizontal	360°
Apex angle, vertical	75°
Maximum power	10 W
VSWR	≤ 2.0

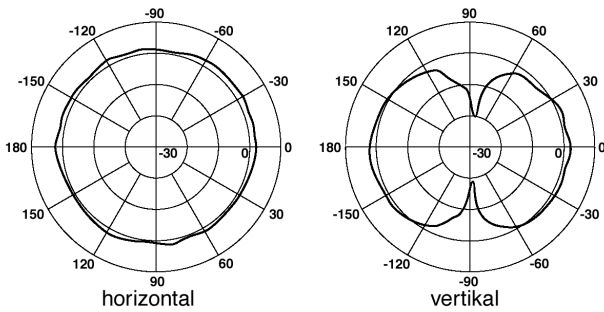

Figure 8 Directional characteristics of the omnidirectional antenna



Figure 10 RAD-ISM-2400-ANT-OMNI-2-1 omnidirectional antenna

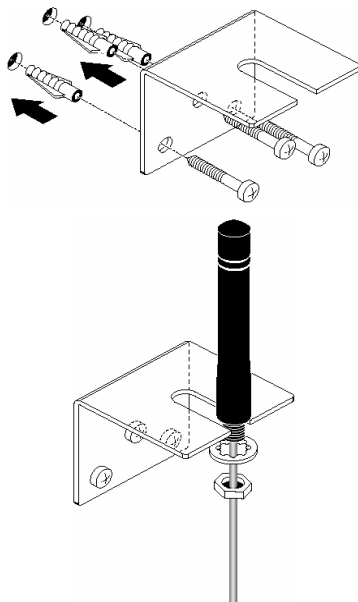

Figure 9 Wall mounting

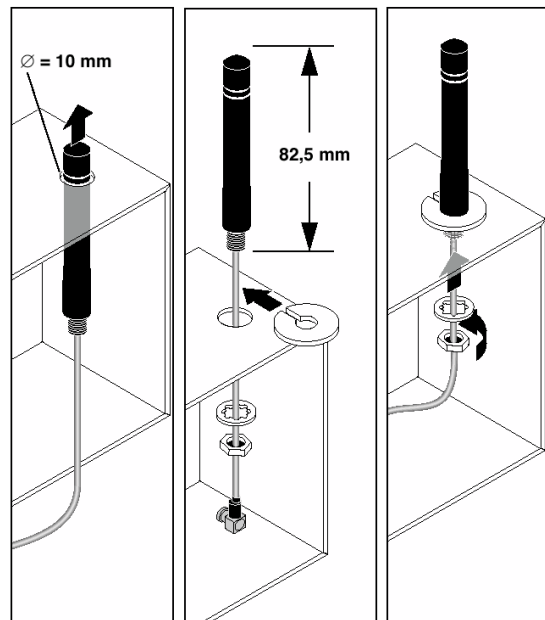

Figure 11 Hole mounting

Technical data for the RAD-ISM-2400-ANT-OMNI-5-0 omnidirectional antenna (Order No. 2884923)

Frequency range	2.4 GHz ... 2.5 GHz
Ambient temperature range (operation/storage)	-20°C ... +65°C
Degree of protection	IP55
Impedance	50 Ω
Gain	5 dBi
Connection	SMA (male connector)
Polarization	Linear, vertical
Apex angle, horizontal	360°
Apex angle, vertical	45°
Maximum power	1 W
VSWR	≤ 2.0

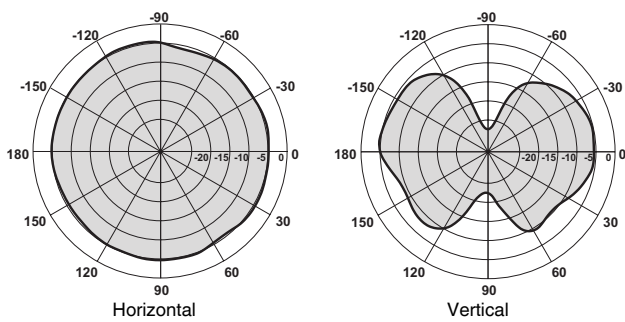

Figure 12 Directional characteristics of the omnidirectional antenna



Figure 14 RAD-ISM-2400-ANT-OMNI-5-0 omnidirectional antenna

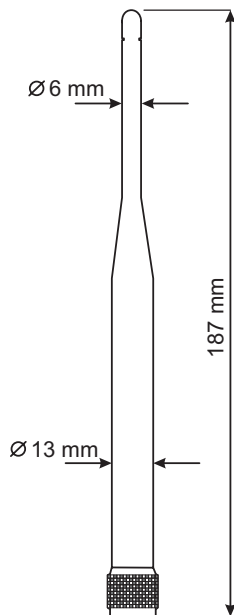

Figure 13 Dimensions

WIRELESS ACCESSORIES

Technical data for RAD-ISM-2400-ANT-VAN-3-1-... omnidirectional antennas (Order No. 2885702 (MCX), 2885867 (SMA))

Frequency range	2.4 GHz ... 2.5 GHz
Ambient temperature range (operation/storage)	-40°C ... +80°C
Degree of protection	IP55
Impact strength	IK 08
Impedance	50 Ω
Gain	3 dBi
Cable length	1.5 m
Connection	MCX (male connector) or SMA (male connector)
Polarization	Linear, vertical
Apex angle, horizontal	360°
Apex angle, vertical	85°
Maximum power	75 W
Downtilt	20°
VSWR	1.5

The rugged omnidirectional antennas with protection against vandalism are suitable for use wherever basic omnidirectional antennas risk potential willful damage. The hemispherical shell is not immediately recognizable as an antenna and offers greater resistance to impact. The antenna connection is routed vertically downwards and thus enables mounting on a control cabinet or housing, as well as outdoors or in areas subject to splash water.

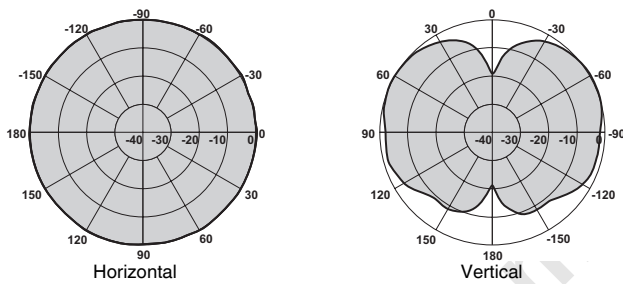

Figure 15 Directional characteristics of the omnidirectional antenna with protection against vandalism

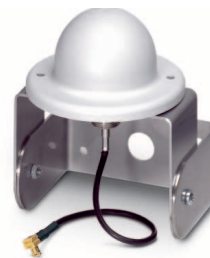

Figure 17 RAD-ISM-2400-ANT-VAN-3-1-MCX omnidirectional antenna

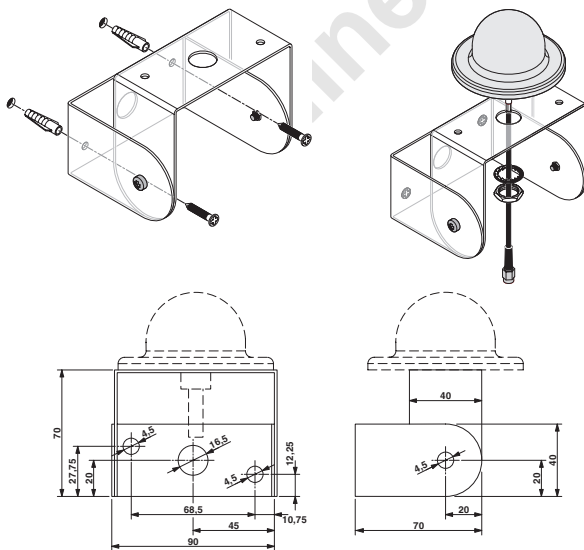

Figure 16 Wall mounting with bracket

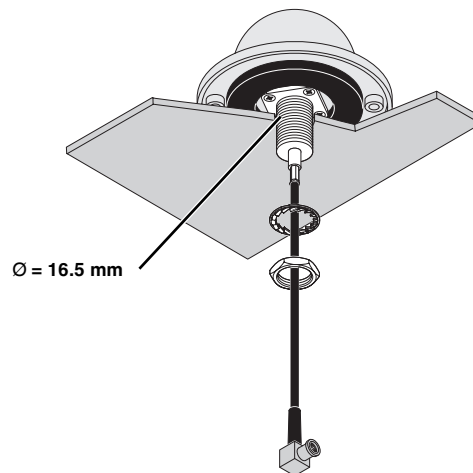

Figure 18 Cabinet mounting

WIRELESS ACCESSORIES

Technical data for the RAD-ISM-2459-ANT-FOOD-6-0 dual band omnidirectional antenna (Order No. 2692526)

Frequency range	2.4 GHz ... 2.5 GHz 5.15 GHz ... 5.83 GHz
Ambient temperature range (operation/storage)	-40°C ... +80°C
Degree of protection	IP68 (when mounted on a level surface)
Impedance	50 Ω
Gain	
2.4 GHz ... 2.5 GHz frequency range	6 dBi (on metal surface) 3 dBi (no metal surface)
5.15 GHz ... 5.83 GHz frequency range	8 dBi (on metal surface) 5 dBi (no metal surface)
Cable length	1.5 m
Connection	N (female connector), including N (male connector) ↔ SMA (male connector) pigtail
Polarization	Linear, vertical
Horizontal apex angle	
2.4 GHz ... 2.5 GHz frequency range, 3 dB	360°
5.15 GHz ... 5.83 GHz frequency range, 10 dB	360°
Vertical apex angle	
2.4 GHz ... 2.5 GHz frequency range, 3 dB	50°
5.15 GHz ... 5.83 GHz frequency range, 10 dB	65°
Maximum power	75 W
Downtilt	20°
VSWR	1.8

The rugged IP68 dual band omnidirectional antenna is resistant to various cleaning agents used in the food industry. The antenna connection is routed vertically downwards and thus enables mounting on a control cabinet or housing, as well as outdoors or in areas subject to splash water.

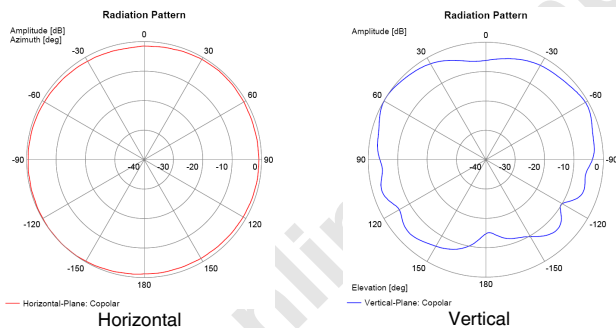

Figure 19 2.4 GHz directional characteristics



Figure 21 RAD-ISM-2459-ANT-FOOD-6-0 dual band omnidirectional antenna

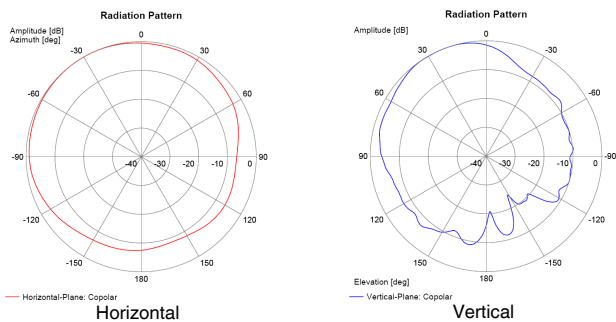

Figure 20 5.6 GHz directional characteristics

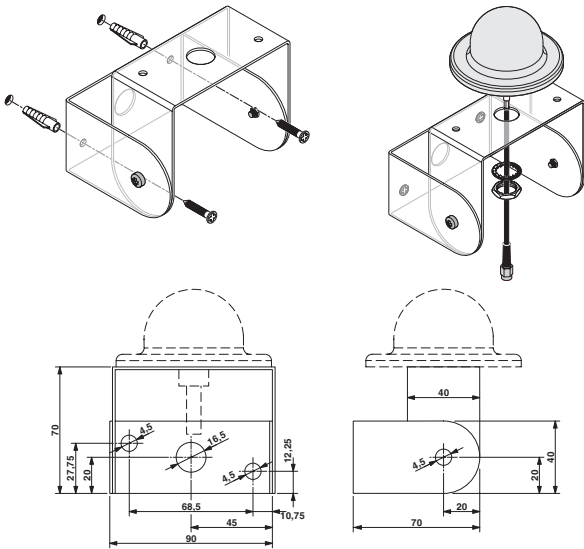

Figure 22 Wall mounting with bracket: RAD-ISM-2459-ANT-FOOD-6-0 with RAD-ANT-VAN-MKT bracket (not supplied as standard)



Figure 23 N (male connector) ↔ SMA (male connector) pigtail

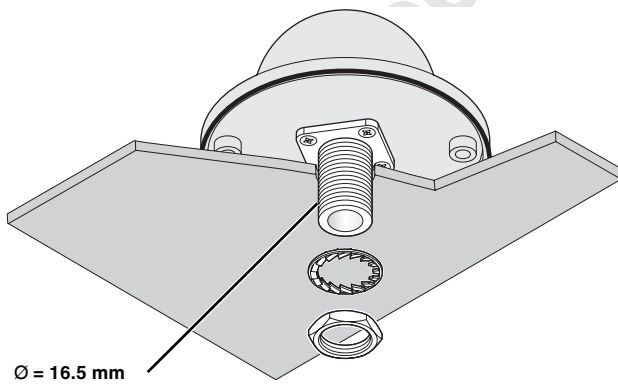

Figure 24 Cabinet mounting (IP68 protection)

WIRELESS ACCESSORIES

Technical data for the RAD-ISM-2400-ANT-OMNI-6-0 omnidirectional antenna (Order No. 2885919)

Frequency range	2.4 GHz ... 2.5 GHz
Ambient temperature range (operation/storage)	-40°C ... +80°C
Degree of protection	IP55
Impedance	50 Ω
Gain	6 dBi
Connection	N (female connector)
Polarization	Linear, vertical
Apex angle, horizontal	360°
Apex angle, vertical	30°
Maximum power	25 W
VSWR	≤ 1.8

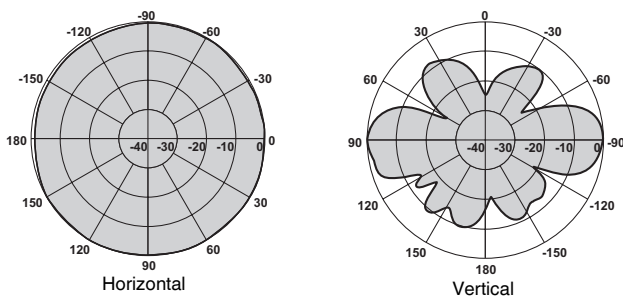

Figure 25 Directional characteristics of the omnidirectional antenna



Figure 27 RAD-ISM-2400-ANT-OMNI-6-0 omnidirectional antenna

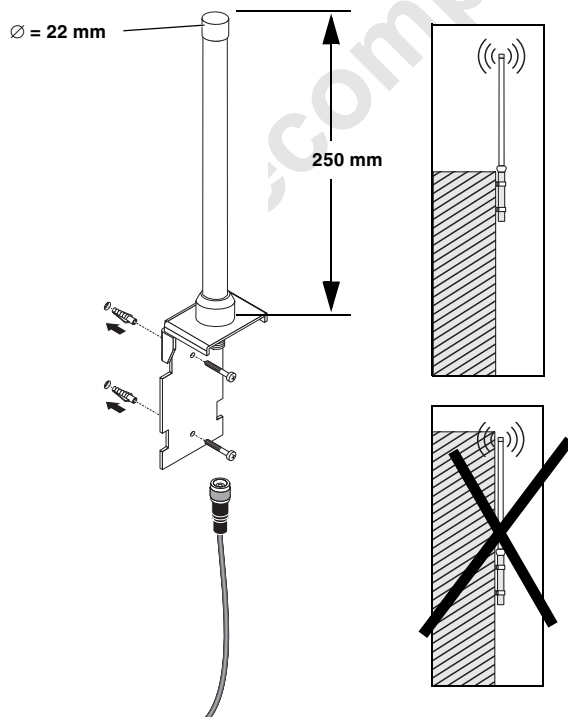

Figure 26 Wall mounting

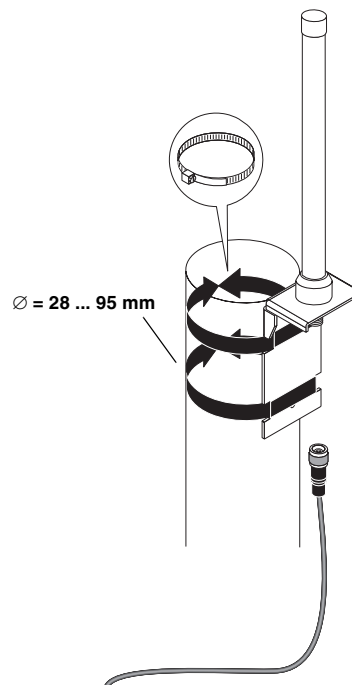

Figure 28 Tube mounting

WIRELESS ACCESSORIES

Technical data for the RAD-ISM-2400-ANT-OMNI-9-0 omnidirectional antenna (Order No. 2867623)

Frequency range	2.4 GHz ... 2.5 GHz
Ambient temperature range (operation/storage)	-40°C ... +75°C
Degree of protection	IP65
Impedance	50 Ω
Gain	9 dBi
Connection	N (female connector)
Polarization	Linear, vertical
Apex angle, horizontal	360°
Apex angle, vertical	15°
Maximum power	20 W
VSWR	≤ 2.0

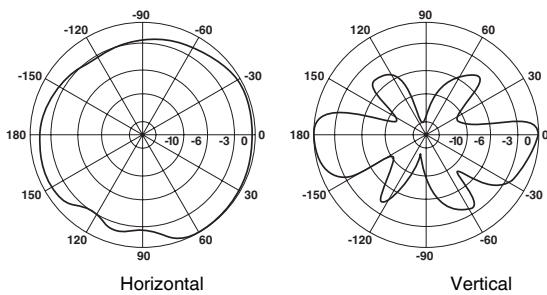

Figure 29 Directional characteristics of the omnidirectional antenna



Figure 31 RAD-ISM-2400-ANT-OMNI-9-0 omnidirectional antenna

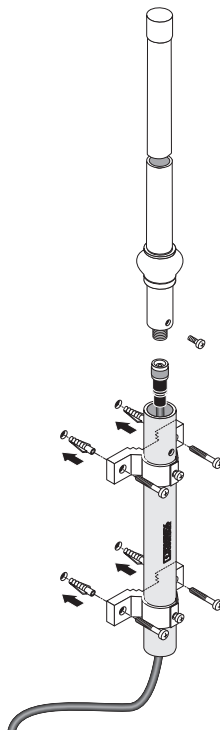

Figure 30 Wall mounting

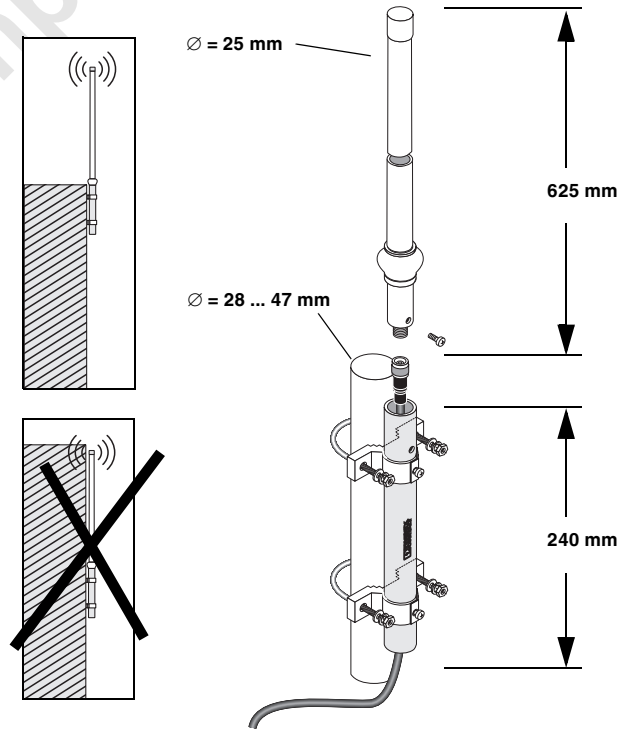

Figure 32 Hole mounting

WIRELESS ACCESSORIES

5.2 Panel antennas

Panel antennas emit the transmission power in a preferred direction. This leads to a range gain (similar to the effect of the reflector in a flashlight). The existing transmission power is therefore not amplified, but simply focused. The same applies for the receiving end. A panel antenna receives signals specifically from the "area" that it is directed at.

The use of a panel antenna is recommended when covering large distances **with a line of sight**.



Figure 33 Panel antennas

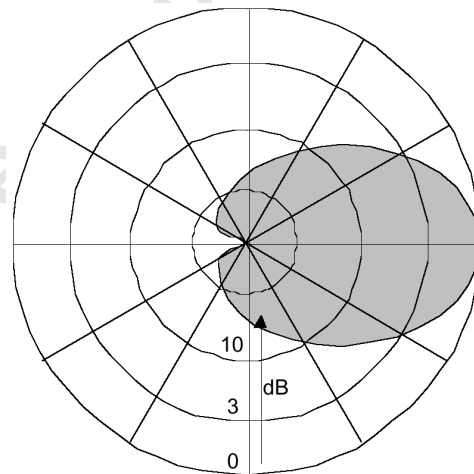

Figure 34 Directional characteristics of a panel antenna

With panel antennas, it is particularly important to ensure that the antenna is mounted securely. An unstable antenna may "sway" or "wobble" in strong winds, which over long distances can move the transmitter or receiver beam out of its target area (Figure 35 (2)).

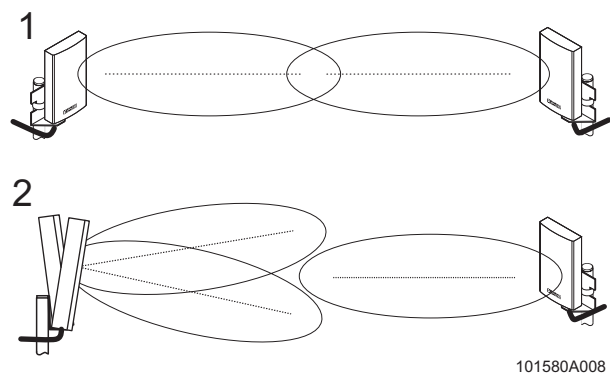

Figure 35 Correct transmitter and receiver beam (1); transmitter and receiver beam outside the target area (2)

Technical data for the RAD-ISM-2400-ANT-PAN-8-0 panel antenna (Order No. 2867610)

Frequency range	2.3 GHz ... 2.8 GHz
Ambient temperature range (operation/storage)	-40°C ... +80°C
Degree of protection	IP55
Impedance	50 Ω
Gain	8 dBi
Dimensions (height x width x depth)	101 mm x 80 mm x 20 mm
Connection	SMA (female connector)
Wind load	15 N at 160 km/h
Polarization	Linear, vertical
Apex angle, horizontal	75°
Apex angle, vertical	70°
Maximum power	75 W
VSWR	1.5

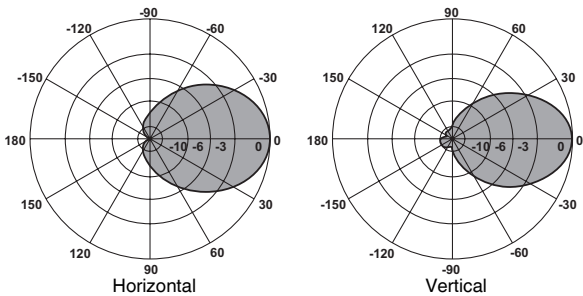

Figure 36 Directional characteristics of the panel antenna

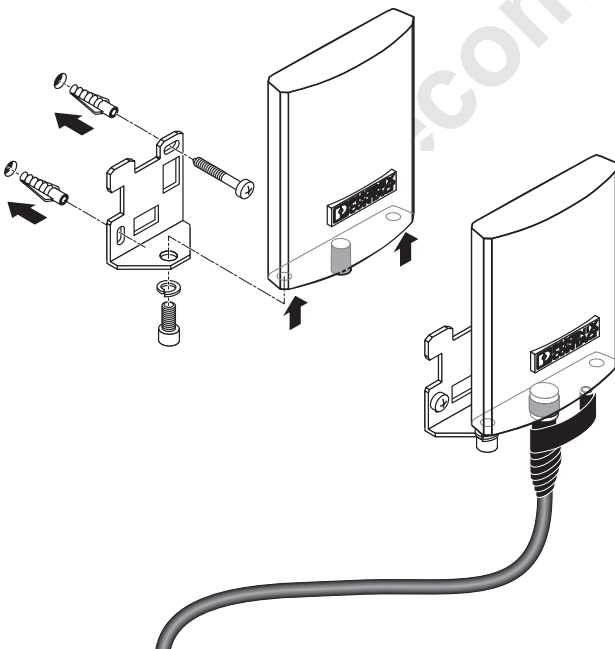

Figure 37 Wall mounting



Figure 38 RAD-ISM-2400-ANT-PAN-8-0 panel antenna

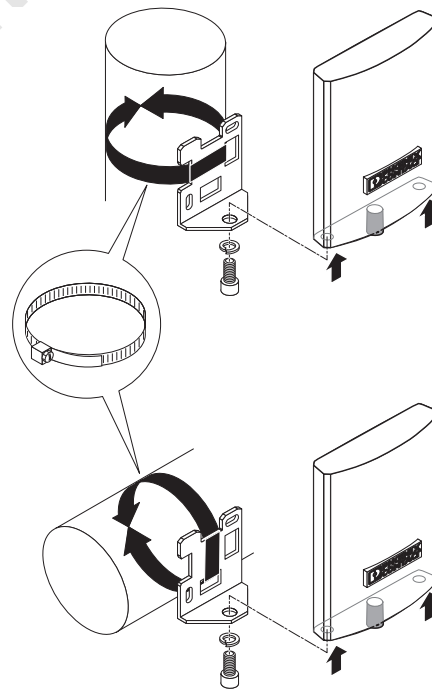

Figure 39 Tube mounting



Protect the SMA plug-in connection using sealing tape (see Figure 37).

Technical data for the RAD-ISM-2400-ANT-CIR-8-0 panel antenna (Order No. 2884936)

Frequency range	2.4 GHz ... 2.5 GHz
Ambient temperature range (operation/storage)	-40°C ... +80°C
Degree of protection	IP55
Impedance	50 Ω
Gain	8 dBi
Dimensions (height x width x depth)	102 mm x 95 mm x 32 mm
Connection	SMA (female connector)
Polarization	Right-hand circular (RHCP)
Wind load	15 N at 160 km/h
Polarization	Linear, vertical or horizontal
Apex angle, horizontal	70°
Apex angle, vertical	65°
Maximum power	75 W
VSWR	1.5

Panel antenna with a special type of polarization (circular, instead of linear polarization which is otherwise used) for applications in highly reflective environments (industrial halls with a lot of metal). This antenna prevents polarization losses due to reflections. The antennas should always be used in pairs.

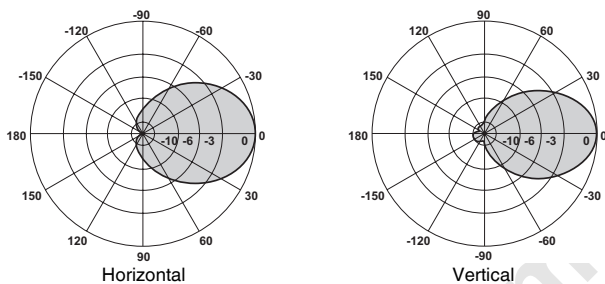

Figure 40 Directional characteristics of the panel antenna



Figure 42 RAD-ISM-2400-ANT-CIR-8-0 panel antenna

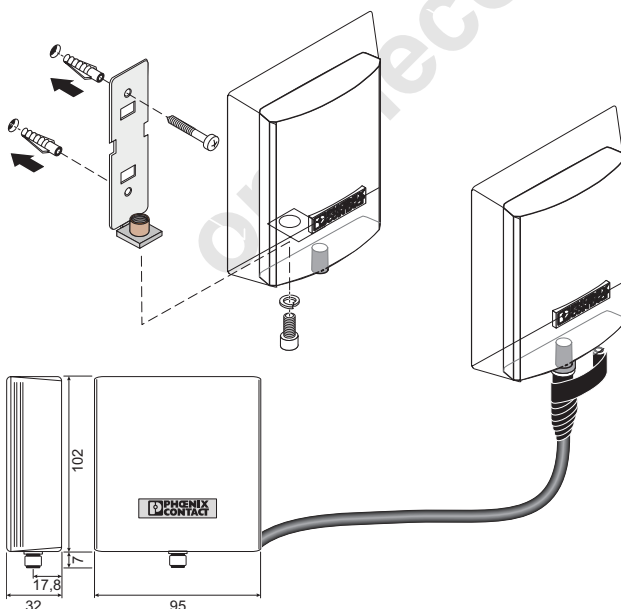

Figure 41 Wall mounting

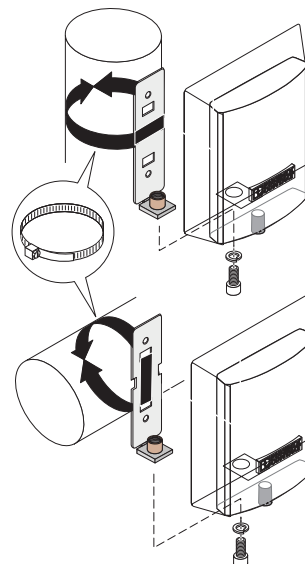

Figure 43 Tube mounting



Protect the SMA plug-in connection using sealing tape (see Figure 41).

WIRELESS ACCESSORIES

Technical data for the RAD-ISM-2400-ANT-PAR-19-0 parabolic antenna (Order No. 2867885)

Frequency range	2.4 GHz ... 2.485 GHz
Ambient temperature range (operation/storage)	-40°C ... +70°C
Degree of protection	IP65
Impedance	50 Ω
Gain	19 dBi
Weight	2.7 kg
Dimensions (height x width)	419 mm x 610 mm
Connection	N (female connector)
Wind load	20 N at 160 km/h
Apex angle, horizontal	17°
Apex angle, vertical	11°
Maximum power	100 W
VSWR	1.5

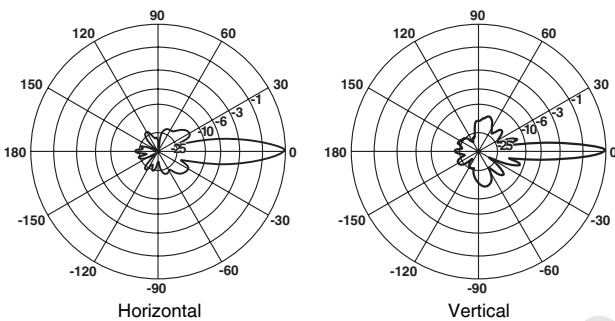

Figure 44 Directional characteristics of the parabolic antenna



Figure 46 RAD-ISM-2400-ANT-PAR-19-0 parabolic antenna

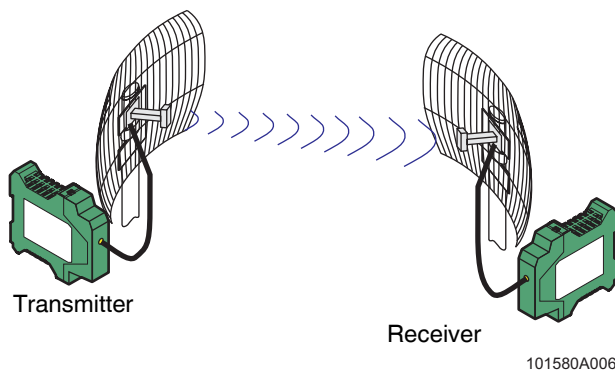

Figure 45 Using the RAD-ISM-2400-ANT-PAR-19-0 parabolic antenna



The parabolic antenna may only be used on a unidirectional transmitter and on bidirectional transceivers in conjunction with the RAD-CAB-EF393-15M extension cable, otherwise the maximum permissible value for emitted power of 20 dB is exceeded.

WIRELESS ACCESSORIES

Mounting the RAD-ISM-2400-ANT-PAR-19-0 parabolic antenna

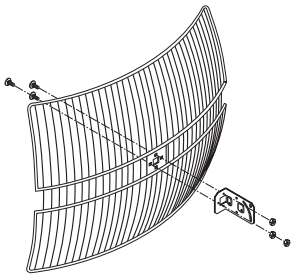

Figure 47 Vertical polarization

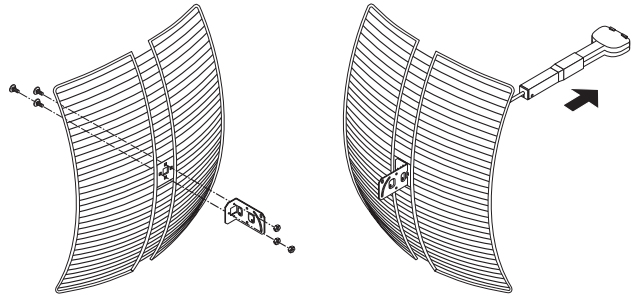
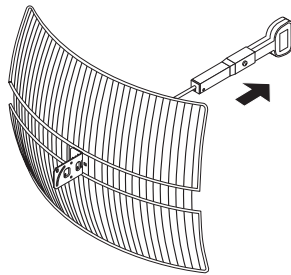

Figure 48 Horizontal polarization

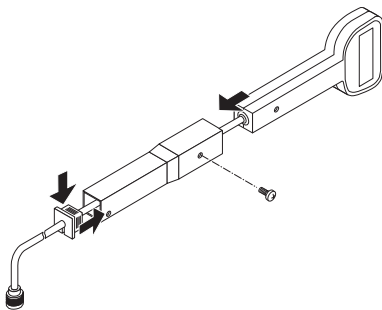

Figure 49 Mounting the feed

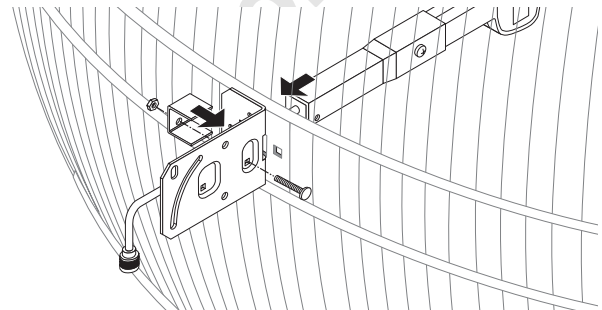

Figure 50 Mounting the feed on the parabolic antenna

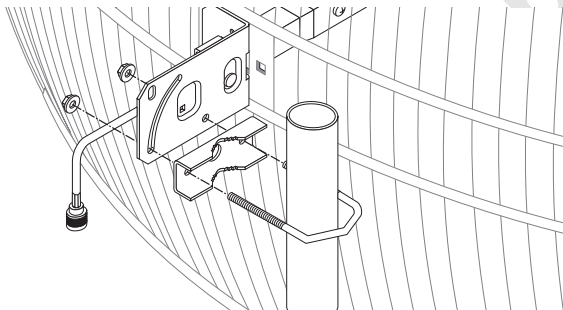

Figure 51 Mounting the parabolic antenna on a mast

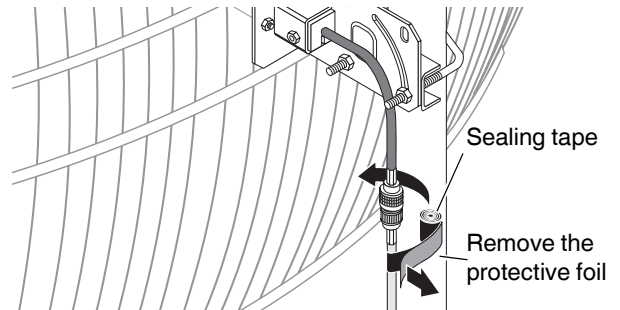

Figure 52 Removing the protective foil from the sealing tape

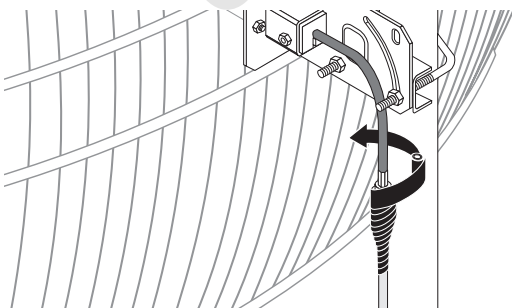

Figure 53 Attaching sealing tape

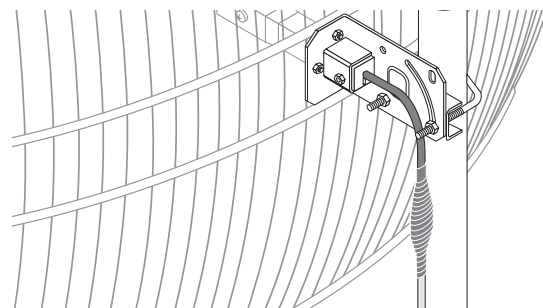

Figure 54 Cable protected

WIRELESS ACCESSORIES

5.3 Type EF393 antenna extension cables



Description	Type	Order No.
Antenna cable, N (male connector) connection at both ends		
3 m length	RAD-CAB-EF393-3M	2867649
5 m length	RAD-CAB-EF393-5M	2867652
10 m length	RAD-CAB-EF393-10M	2867665
15 m length	RAD-CAB-EF393-15M	2885634



Please note that each connection element between the antenna and the device causes signal attenuation. The attenuation of a cable, for example, is proportional to the length of the cable. Therefore use only as much cable as is absolutely necessary for the application.

Technical data for RAD-CAB-EF393-... antenna cables

Connector type	N (male connector) at both ends
Outer material	Brass
Ambient temperature range (operation/storage)	-40°C ... +105°C
Cable type	EF393
Outside diameter	10 mm
Minimum bending radius	50 mm
Weight	18 kg/100 m
Insertion loss	
900 MHz	0.27 dB/m, approximately
1.8 GHz	0.44 dB/m, approximately
2.4 GHz	0.54 dB/m, approximately
5 GHz	0.97 dB/m, approximately
Outer cable sheath	RADOX LSFH (Low Smoke Free of Halogen)
Impedance	50 Ω

5.4 Type EF142 antenna extension cables



Description	Type	Order No.
Antenna cable, SMA (male connector) connection at both ends		
3 m length	RAD-CAB-EF142-3M	2884512
5 m length	RAD-CAB-EF142-5M	2884525



Please note that each connection element between the antenna and the device causes signal attenuation. The attenuation of a cable, for example, is proportional to the length of the cable. Therefore use only as much cable as is absolutely necessary for the application.

WIRELESS ACCESSORIES

Technical data for RAD-CAB-EF142-... antenna cables

Connector type	SMA (male connector) at both ends
Outer material	Brass
Ambient temperature range (operation/storage)	-40°C ... +105°C
Cable type	EF142
Outside diameter	5 mm
Minimum bending radius	30 mm
Weight	6 kg/100 m
Insertion loss	
900 MHz	0.51 dB/m, approximately
1.8 GHz	0.78 dB/m, approximately
2.4 GHz	0.93 dB/m, approximately
5 GHz	1.52 dB/m, approximately
Material of outer cable sheath	RADOX LSFH (Low Smoke Free of Halogen)
Impedance	50 Ω

5.5 Adapter cables (pigtailed)



Description	Type	Order No.
Pigtails (adapter cables)		
MCX (male connector) ↔ SMA (male connector) 100 cm	RAD-PIG-EF316-MCX-SMA	2867678
MCX (male connector) ↔ N (male connector) 50 cm	RAD-PIG-EF316-MCX-N	2867681
N (female connector) ↔ SMA (male connector) 30 cm	RAD-PIG-EF316-N-SMA	2867694
N (male connector) ↔ N (female connector) 50 cm	RAD-PIG-EF316-N-N	2867704
SMA (male connector) ↔ SMA (male connector) 50 cm	RAD-PIG-EF-316-SMA-SMA	2885618

Technical data for RAD-PIG-EF316-... pigtailed

Connector type	See above
Outer material	Brass or high-grade steel
Ambient temperature range (operation/storage)	-40°C ... +70°C
Cable type	EF316D
Outside diameter	3.2 mm
Minimum bending radius	5 mm
Weight	2.1 kg/100 m
Insertion loss	
900 MHz	0.83 dB/m, approximately
1.8 GHz	1.27 dB/m, approximately
2.4 GHz	1.52 dB/m, approximately
5 GHz	2.48 dB/m, approximately
Material of outer cable sheath	RADOX LSFH (Low Smoke Free of Halogen)
Impedance	50 Ω

WIRELESS ACCESSORIES

5.6 Adapter cable with HF gasket sleeve

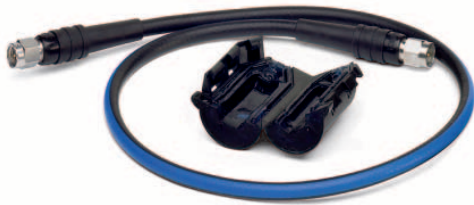

The RAD-PIG-EF142-PIPE set comprises one pigtail and one HF gasket sleeve. It enables external antennas from the INTERFACE Wireless accessories range to be connected to RAD-ISM-2400-PIPE-... modules by means of weatherproof connection.

Description	Type	Order No.
Pigtails (adapter cables)		
SMA (male connector) ↔ SMA (male connector) 50 cm	RAD-PIG-EF142-PIPE	2885922

Technical data for the adapter cable

Connector type	See above
Outer material	High-grade steel
Ambient temperature range (operation/storage)	-40°C ... +105°C
Cable type	EF142
Outside diameter	5 mm
Minimum bending radius	30 mm
Weight	6 kg/100 m
Insertion loss (see 5.4 "Type EF142 antenna extension cables")	0.93 dB/m
Material of outer cable sheath	RADOX LSFH (Low Smoke Free of Halogen)
Impedance	50 Ω

Technical data for the HF gasket sleeve

Gasket material	Gel cushion (UV-resistant)
Cable diameter	3.5 mm ... 7 mm
Ambient temperature range (operation/storage)	-30°C ... +70°C
Reusability	Can be opened up to 20 times

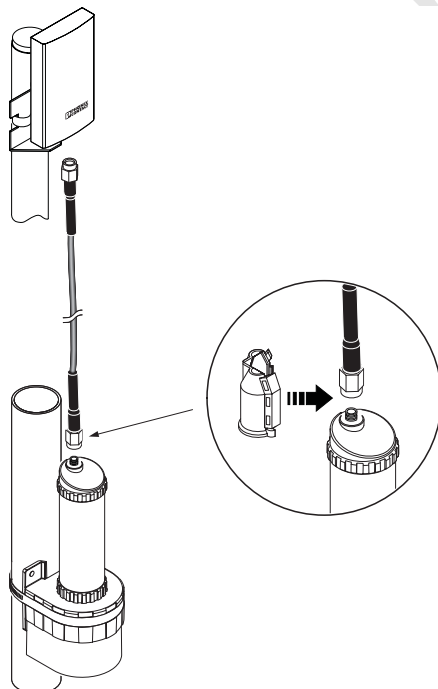

Figure 55 Connecting the adapter cable

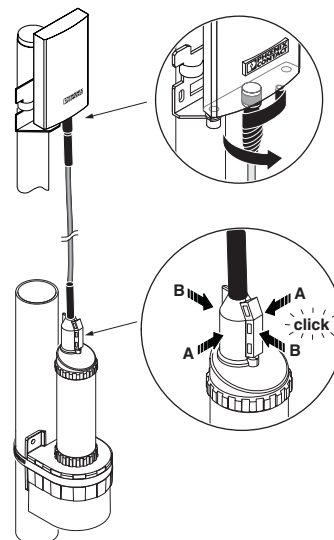

Figure 56 Mounting the HF gasket sleeve



Protect the SMA plug-in connection using sealing tape (see Figure 56).

WIRELESS ACCESSORIES

5.7 2.4 GHz surge protection adapters



Surge protection adapters with Lambda/4 technology are available for installing antennas **outside** buildings.

Description	Type	Order No.
N (female connector) ↔ N (female connector) surge protection adapter	CN-LAMBDA/4-2.0-BB	2818863
N (male connector) ↔ N (female connector) surge protection adapter	CN-LAMBDA/4-2.0-SB	2818876

Technical data for CN-LAMBDA/4-2.0-... COAXTRAB surge protection adapters

Connector type	See above
Frequency range	1.7 GHz ... 2.4 GHz
Insertion loss at 2.4 GHz ... 2.5 GHz	< 0.3 dB
Degree of protection	IP55
Ambient temperature range (operation)	-40°C ... +100°C
Impedance	50 Ω

5.8 5 GHz surge protection adapters



Surge protection adapters with Lambda/4 technology are available for installing antennas **outside** buildings.

Description	Type	Order No.
N (female connector) ↔ N (female connector) surge protection adapter	CN-LAMBDA/4-2.0-BB	2838490
N (male connector) ↔ N (female connector) surge protection adapter	CN-LAMBDA/4-2.0-SB	2800023

Technical data for CN-LAMBDA/4-2.0-... COAXTRAB surge protection adapters

Connector type	See above
Frequency range	2.4 GHz ... 5.9 GHz
Insertion loss (typical/maximum)	< 0.05/0.15 dB
Degree of protection	IP68
Ambient temperature range (operation)	-40°C ... +100°C
Impedance	50 Ω

WIRELESS ACCESSORIES

5.9 Adapters



Several adapters are available for installing antennas. The RSMA adapter features a female connector with inner thread.

Description	Type	Order No.
① N (female connector) ↔ N (female connector) adapter	RAD-ADP-N/F-N/F	2867843
② N (male connector) ↔ SMA (female connector) adapter	RAD-ADP-N/M-SMA/F	2917036
③ SMA (female connector) ↔ SMA (female connector) adapter	RAD-ADP-SMA/F-SMA/F	2884541
④ RSMA (female connector) ↔ SMA (female connector) adapter	RAD-ADP-RSMA/F-SMA/F	2884538
⑤ SMA (female connector) ↔ SMA (male connector) right-angle adapter	RAD-ADP-SMA/F-SMA/M-90	2917324

Technical data for RAD-ADP-... adapters

Connector type	See above
Insertion loss at 2.4 GHz ... 2.5 GHz	< 0.3 dB
Ambient temperature range (operation/storage)	-65°C ... +165°C
Impedance	50 Ω

5.10 Vulcanizing sealing tape



Vulcanizing sealing tape can be used to provide external protection for adapters, antenna splitters, cable connections, etc. against the effects of weather.

Technical data for RAD-TAPE-SV-25-10 sealing tape (Order No. 2885812)

Vulcanizing	Yes
Color	Black
Roll dimensions (length x width x thickness)	10 m x 25 mm x 0.75 mm

WIRELESS ACCESSORIES

5.11 Antenna splitter sets



Description	Type	Order No.
Antenna splitter set, 4-way, comprising 1 antenna splitter, 2 termination resistors, and 1 adapter	RAD-ISM-2400-SPL-4-SMA	2867856
Antenna splitter set, 2-way, comprising 1 antenna splitter, 1 adapter, and 4 strips of vulcanizing sealing tape	RAD-ISM-2400-SPL-2-SMA	2885595
Technical data for antenna splitter sets		
RAD-ISM-2400-SPL-4-SMA		
RAD-ISM-2400-SPL-2-SMA		
Antenna splitter ①		
Impedance	50 Ω	
Connection method	4 x SMA female connector, 1 x SMA male connector	2 x SMA female connector, 1 x SMA male connector
Attenuation per path at 2.4 GHz ... 2.5 GHz	6 dB	3 dB
Isolation between the ports	12 dB	6 dB
Degree of protection	IP20	
Temperature range	-40°C ... +85°C	
Termination resistor ②		
Impedance	50 Ω	-
Connection method	SMA (male connector)	-
VSWR	1.10	-
Temperature range	-40°C ... +85°C	-
Coupling torque	0.45 Nm	-
Weight	3.3 g	-
Adapter ③		
Impedance	50 Ω	
Connection method	N (male connector) ↔ SMA (female connector)	N (female connector) ↔ SMA (female connector)
Weight	30 g	

6 Antennas and accessories for GSM/UMTS

6.1 GSM/UMTS antennas

Technical data for GSM(/UMTS) quad band omnidirectional antennas	PSI-GSM-QB-ANT (Order No. 2313135)	PSI-GSM/UMTS-QB-ANT (Order No. 2313371)
Frequency range	850/900/1800/1900 MHz	850/900/1800/1900/2100 MHz
Ambient temperature range (operation/storage)	-40°C ... +105°C	-40°C ... +105°C
Degree of protection	IPX9K	IPX9K
Impedance	50 Ω	50 Ω
Gain	1 dB	1 dB
Connection	SMA (male connector)	SMA (male connector)
Cable length	2 m	3 m
VSWR	≤ 2.0	≤ 2.0
Dimensions		
Diameter	76 mm	76 mm
Height	20 mm	23 mm

The PSI-GSM-QB-ANT GSM quad band antenna is suitable for GSM networks operating in the 850 MHz, 900 MHz, 1800 MHz, and 1900 MHz frequency bands. The PSI-GSM/UMTS-QB-ANT GSM/UMTS quad band antenna is suitable for GSM/UMTS networks operating in the 850 MHz, 900 MHz, 1800 MHz, 1900 MHz, and 2100 MHz frequency bands. They can be mounted on any level surface.

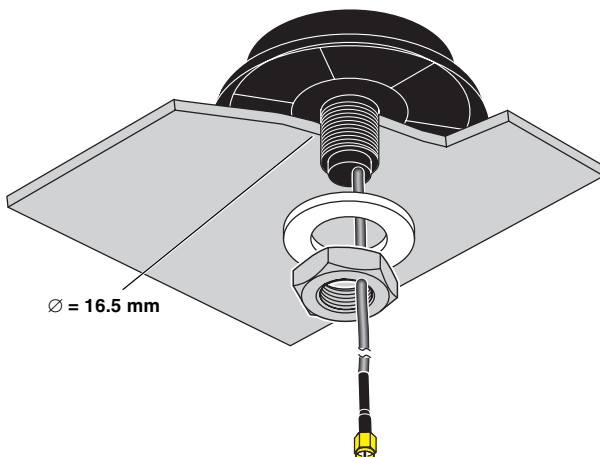

Figure 57 Mounting



Figure 58 PSI-GSM-QB-ANT
GSM quad band omnidirectional antenna

Technical data for the PSI-GSM-STUB-ANT GSM quad band omnidirectional antenna (Order No. 2313342)

Frequency range	850/900/1800/1900/2100 MHz
Ambient temperature range (operation/storage)	-40°C ... +105°C
Degree of protection	IPX9K
Impedance	50 Ω
Gain	1 dB
Connection	SMA (male connector)
VSWR	≤ 2.0
Dimensions	
Diameter	11 mm
Height	95 mm

The PSI-GSM-STUB-ANT GSM quad band antenna is suitable for GSM networks operating in the 850 MHz, 900 MHz, 1800 MHz, 1900 MHz, and 2100 MHz frequency bands.



Figure 59 PSI-GSM-STUB-ANT
GSM quad band omnidirectional antenna

Technical data for the PSI-GSM-UMTS-ANT-OMNI-2-5 quad band omnidirectional antenna (Order No. 2900982)

Frequency range	850/900/1800/1900/2100 MHz
Ambient temperature range (operation/storage)	-40°C ... +80°C
Degree of protection	IP65
Impedance	50 Ω
Gain	2 dBi
Connection	SMA (male connector)
VSWR	≤ 1.4
Dimensions	
Diameter	20 mm
Height	212 mm

The PSI-GSM-STUB-ANT-OMNI-2-5 GSM quad band antenna is suitable for GSM/UMTS networks operating in the 850 MHz, 900 MHz, 1800 MHz, 1900 MHz, and 2100 MHz frequency bands.



Figure 60 PSI-GSM-STUB-ANT-OMNI-2-5 GSM/UMTS
quad band omnidirectional antenna

WIRELESS ACCESSORIES

6.2 GSM/UMTS antenna cables



Description	Type	Order No.
Antenna cable, SMA (male connector) ↔ SMA (female connector) connection		
5 m length	PSI-CAB-GSM/UMTS-5M	2900980
10 m length	PSI-CAB-GSM/UMTS-10M	2900981



Please note that each connection element between the antenna and the device causes signal attenuation. The attenuation of a cable, for example, is proportional to the length of the cable. Therefore use only as much cable as is absolutely necessary for the application.

Technical data for PSI-CAB-GSM/UMTS-...M antenna cables

Connector type	SMA (male connector) ↔ SMA (female connector)
Outer material	Brass
Ambient temperature range (operation/storage)	-40°C ... +85°C
Outside diameter	5.5 mm
Minimum bending radius	82 mm
Weight	4.78 kg/100 m
Insertion loss	
900 MHz	0.24 dB/m, approximately
1.8 GHz	0.35 dB/m, approximately
2.4 GHz	0.39 dB/m, approximately
Outer cable sheath	Polyethylene (modified)
Impedance	50 Ω

6.3 Adapter



The following adapter is available for installing antennas. The SMA adapter features a male connector with inner thread.

Technical data for the RAD-ADP-SMA/F-SMA/M-90 adapter (Order No. 2917324)

Connector type	SMA (female connector) ↔ SMA (male connector)
Insertion loss at 2.4 GHz ... 2.5 GHz	< 0.3 dB
Ambient temperature range (operation/storage)	-65°C ... +165°C
Impedance	50 Ω

6.4 Vulcanizing sealing tape



Vulcanizing sealing tape can be used to provide external protection for adapters, antenna splitters, cable connections, etc. against the effects of weather.

Technical data for RAD-TAPE-SV-25-10 sealing tape (Order No. 2885812)

Vulcanizing	Yes
Color	Black
Roll dimensions (length x width x thickness)	10 m x 25 mm x 0.75 mm

onlinecomponents.com

7 Selection guide and application examples

Depending on the various types of antenna and various cable diameters, different connector types are used (e.g., MCX, SMA, N).

RAD-CAB-EF393... antenna extension cables are designed for **outdoor** installation and for low attenuation. They require rugged N type connectors.

RAD-CAB-EF142... antenna extension cables are designed for **indoor** installation and for small bending radii. They require SMA type connectors.

For short cable paths (e.g., out of the control box), smaller cable diameters and thus smaller connectors (MCX or SMA) can be used. Various adapter cables, known as pigtails, are therefore required to connect all components in the system.



The declaration of conformity does not permit the use of any other components.

Protect connectors installed outdoors against humidity using sealing tape.

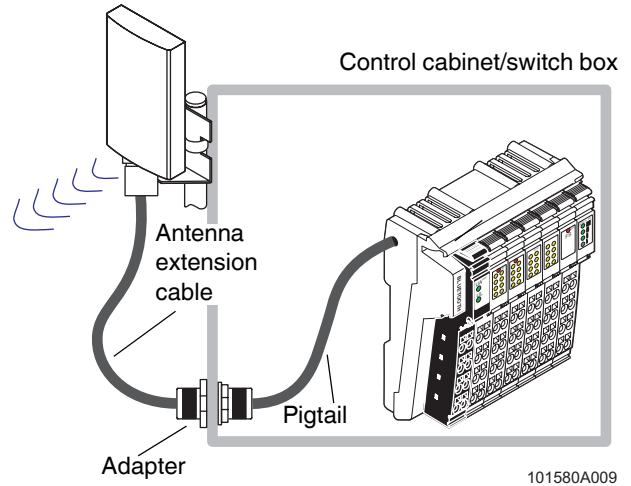

Figure 62 Example for cable connections using ILB BT ADIO MUX... (indoors)

7.1 Pigtail selection tables

The tables on the following pages provide an overview of how the various antennas and their accessories should be used with Phoenix Contact wireless products.

The left column lists the various antennas, while the next column lists the corresponding antenna extension cables, if required.

The third column specifies whether surge protection (for outdoor applications) or an adapter (for indoor applications) is required.

The column on the right lists additional pigtails, if required.

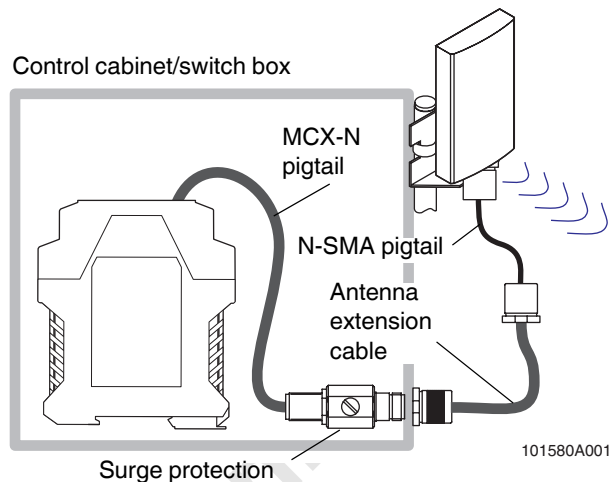

Figure 61 Example for cable connections using RAD-ISM-2400-... (outdoors)



When using an extension cable for outdoor applications, surge protection is recommended.



Make sure that the maximum permissible emitted power for your country is not exceeded (Europe: 20 dBm, maximum).

WIRELESS ACCESSORIES

Pigtail selection table for RAD-ISM-2400-... and PSI-...



Type of antenna used	Required antenna extension cables	Installation outdoors or indoors	Required pigtails
Omnidirectional antenna RAD-ISM-2400-ANT-OMNI-2-1 Order No. 2867461 MCX (male connector)	- (Do not use any antenna extension cables with these antennas so as to avoid excessively high attenuation.)	Outdoors and indoors: - ¹	-
Omnidirectional antenna RAD-ISM-2400-ANT-VAN-3-1-MCX Order No. 2885702 MCX (male connector)			
Omnidirectional antenna RAD-ISM-2400-ANT-OMNI-6-0 Order No. 2885919 N (female connector)	RAD-CAB-EF393-... Order No. 2867649 (3 m) Order No. 2867652 (5 m) Order No. 2867665 (10 m) Order No. 2885634 (15 m)	Outdoors: CN-LAMBDA/4-2.0-BB surge protection (Order No. 2818863) Indoors: RAD-ADP-N/F-N/F adapter (Order No. 2867843)	RAD-PIG-EF316-MCX-N (Order No. 2867681)
Omnidirectional antenna RAD-ISM-2400-ANT-OMNI-9-0 Order No. 2867623 N (female connector)	-	Outdoors: CN-LAMBDA/4-2.0-SB surge protection (Order No. 2818876) Indoors: - ¹	RAD-PIG-EF316-MCX-N (Order No. 2867681) RAD-PIG-EF316-N-N (Order No. 2867704)
Panel antenna RAD-ISM-2400-ANT-PAN-8-0 Order No. 2867610 SMA (female connector)	RAD-CAB-EF393-... Order No. 2867649 (3 m) Order No. 2867652 (5 m) Order No. 2867665 (10 m) Order No. 2885634 (15 m)	Outdoors: CN-LAMBDA/4-2.0-BB surge protection (Order No. 2818863) Indoors: RAD-ADP-N/F-N/F adapter (Order No. 2867843)	RAD-PIG-EF316-MCX-N (Order No. 2867681) RAD-PIG-EF316-N-SMA (Order No. 2867694)
Circular panel antenna ² RAD-ISM-2400-ANT-CIR-8-0 Order No. 2884936 SMA (female connector)	-	Outdoors: CN-LAMBDA/4-2.0-SB surge protection (Order No. 2818876) Indoors: - ¹	RAD-PIG-EF316-MCX-N (Order No. 2867681) RAD-PIG-EF316-N-SMA (Order No. 2867694)
Parabolic antenna RAD-ISM-2400-ANT-PAR 19-0 Order No. 2867885 N (female connector)	RAD-CAB-EF393-15M (Order No. 2885634) (The parabolic antenna may only be used on a unidirectional transmitter and on bidirectional transceivers in conjunction with the 15 m extension cable, otherwise the maximum permissible value for emitted power of 20 dB is exceeded.)	Outdoors: CN-LAMBDA/4-2.0-BB surge protection (Order No. 2818863) Indoors: RAD-ADP-N/F-N/F adapter (Order No. 2867843)	RAD-PIG-EF316-MCX-N (Order No. 2867681)

¹ Surge protection or adapter not required.

² Circular panel antenna for special applications in highly reflective environments

WIRELESS ACCESSORIES

Pigtail selection table for RAD-ISM-2400-PIPE-...



Type of antenna used	Required antenna extension cables	Required adapter or surge protection	Required pigtails
Omnidirectional antenna RAD-ISM-2400-ANT-OMNI-5-0 Order No. 2884923 SMA (male connector)	- (Antenna for direct mounting on the device)	-	-
Omnidirectional antenna RAD-ISM-2400-ANT-OMNI-6-0 Order No. 2885919 N (female connector)	RAD-CAB-EF142-... Order No. 2884512 (3 m) Order No. 2884525 (5 m)	RAD-ADP-SMA/F-SMA/F (Order No. 2884541) RAD-ADP-N/M-SMA/F (Order No. 2917036)	RAD-PIG-EF142-PIPE (Order No. 2885922)
Omnidirectional antenna RAD-ISM-2400-ANT-OMNI-9-0 Order No. 2867623 N (female connector)	-	RAD-ADP-N/M-SMA/F (Order No. 2917036)	
Panel antenna RAD-ISM-2400-ANT-PAN-8-0 Order No. 2867610 SMA (female connector)	RAD-CAB-EF142-... Order No. 2884512 (3 m) Order No. 2884525 (5 m)	RAD-ADP-SMA/F-SMA/F (Order No. 2884541)	RAD-PIG-EF142-PIPE (Order No. 2885922)
Circular panel antenna ¹ RAD-ISM-2400-ANT-CIR-8-0 Order No. 2884936 SMA (female connector)	-	-	

¹ Circular panel antenna for special applications in highly reflective environments

WIRELESS ACCESSORIES

Pigtail selection table for ILB BT ADIO MUX...



Type of antenna used	Required antenna extension cables	Required adapter or surge protection	Required pigtails
Omnidirectional antenna RAD-ISM-2400-ANT-OMNI-2-1 Order No. 2867461 MCX (male connector) Omnidirectional antenna RAD-ISM-2400-ANT-VAN-3-1-MCX Order No. 2885702 MCX (male connector)	- (Do not use any antenna extension cables with these antennas so as to avoid excessively high attenuation.)	Outdoors ¹ and indoors: -	-
Omnidirectional antenna RAD-ISM-2400-ANT-OMNI-6-0 Order No. 2885919 N (female connector) Omnidirectional antenna RAD-ISM-2400-ANT-OMNI-9-0 Order No. 2867623 N (female connector)	RAD-CAB-EF393-... Order No. 2867649 (3 m) Order No. 2867652 (5 m) Order No. 2867665 (10 m) Order No. 2885634 (15 m)	Outdoors: CN-LAMBDA/4-2.0-BB surge protection (Order No. 2818863) Indoors: RAD-ADP-N/F-N/F adapter (Order No. 2867843)	RAD-PIG-EF316-MCX-N (Order No. 2867681)
Panel antenna RAD-ISM-2400-ANT-PAN-8-0 Order No. 2867610 SMA (female connector) Circular panel antenna ² RAD-ISM-2400-ANT-CIR-8-0 Order No. 2884936 SMA (female connector)	RAD-CAB-EF142-... Order No. 2884512 (3 m) Order No. 2884525 (5 m)	Outdoors and indoors: RAD-ADP-SMA/F-SMA/F adapter (Order No. 2884541)	RAD-PIG-EF316-MCX-SMA (Order No. 2867678)
	-	Outdoors ¹ and indoors: -	

¹ Provide lightning protection.

² For special applications in highly reflective environments

WIRELESS ACCESSORIES

Pigtail selection table for FL WLAN..., FL BLUETOOTH AP, and FLM BT...



Type of antenna used	Required antenna extension cables	Required adapter or surge protection	Required pigtails
Omnidirectional antenna on the housing (supplied antenna; alternatively: RAD-ISM-2400-ANT-OMNI-5-0 Order No. 2884923 SMA (male connector))	-	Outdoors ¹ and indoors: -	-
Omnidirectional antenna ² (Device antenna with cable extension; alternatively: RAD-ISM-2400-ANT-OMNI-5-0 Order No. 2884923, SMA (male connector))	-	Outdoors: - ¹	-
	RAD-CAB-EF142-... Order No. 2884512 (3 m) Order No. 2884525 (5 m)	Indoors: RAD-ADP-SMA/F-SMA/F adapter (Order No. 2884541)	RAD-PIG-EF316-SMA-SMA (Order No. 2885618)
Omnidirectional antenna RAD-ISM-2400-ANT-VAN-3-0-SMA ³ Order No. 2885867 SMA (male connector)	- (Do not use any antenna extension cables with these antennas so as to avoid excessively high attenuation.)	Indoors: RAD-ADP-SMA/F-SMA/F adapter (Order No. 2884541)	-
Omnidirectional antenna RAD-ISM-2400-ANT-OMNI-6-0 ³ Order No. 2885919 N (female connector) Omnidirectional antenna RAD-ISM-2400-ANT-OMNI-9-0 ³ Order No. 2867623 N (female connector)	RAD-CAB-EF393-... Order No. 2867649 (3 m) Order No. 2867652 (5 m) Order No. 2867665 (10 m) Order No. 2885634 (15 m)	Outdoors: CN-LAMBDA/4-2.0-SB surge protection (Order No. 2818876)	RAD-PIG-EF316-N-SMA (Order No. 2867694)
		Indoors: RAD-ADP-N/F-N/F adapter (Order No. 2867843)	
Panel antenna RAD-ISM-2400-ANT-PAN-8-0 ³ Order No. 2867610 SMA (female connector) Circular panel antenna ^{3 4} RAD-ISM-2400-ANT-CIR-8-0 Order No. 2884936 SMA (female connector)	RAD-CAB-EF142-... Order No. 2884512 (3 m) Order No. 2884525 (5 m)	Outdoors ¹ and indoors: -	-

¹ Provide lightning protection.

² Not for FL WLAN ...

³ Not for FLM BT.... For FL WLAN... and FL BLUETOOTH AP, select the corresponding permissible power level.

⁴ For special applications in highly reflective environments



For FL WLAN..., the RAD-ADP-RSMA/F-SMA/F adapter (Order No. 2884538) is also required in order to connect external antennas.

7.2 Application examples for the RAD-ISM-2400-SPL-4-SMA 4-way antenna splitter set

Figure 63 shows a unidirectional application with two transmitters in the field and a central station with two receivers. Both receivers receive their signal information via only one antenna. In this application, an antenna is eliminated by using a 4-way antenna splitter.

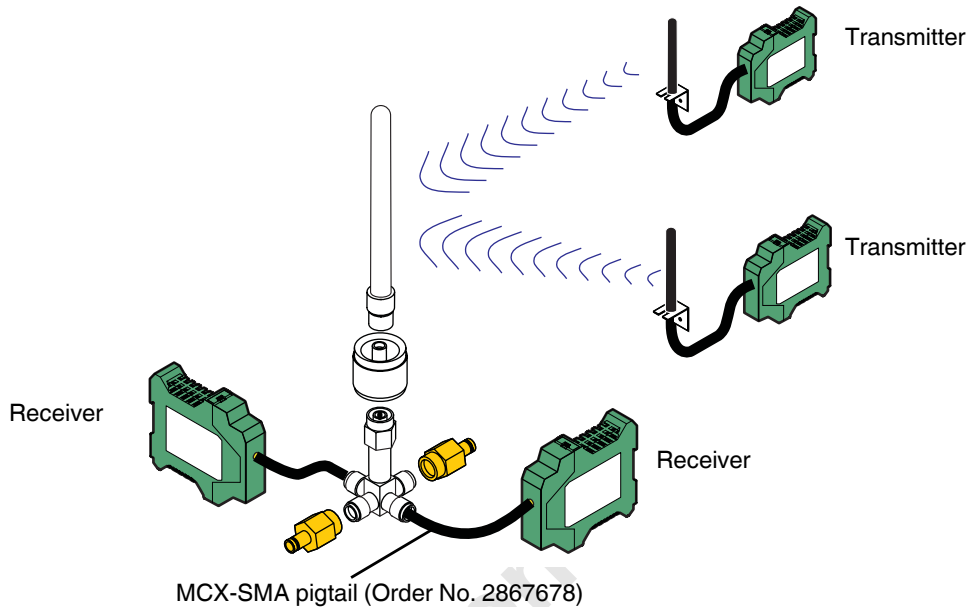

101580B002

Figure 63 Application example with two transmitters and one antenna

Figure 64 shows a unidirectional application with four transmitters in the field and a central station with four receivers. All four receivers receive their signal information via only one antenna. In this application, three antennas are eliminated by using a 4-way antenna splitter.

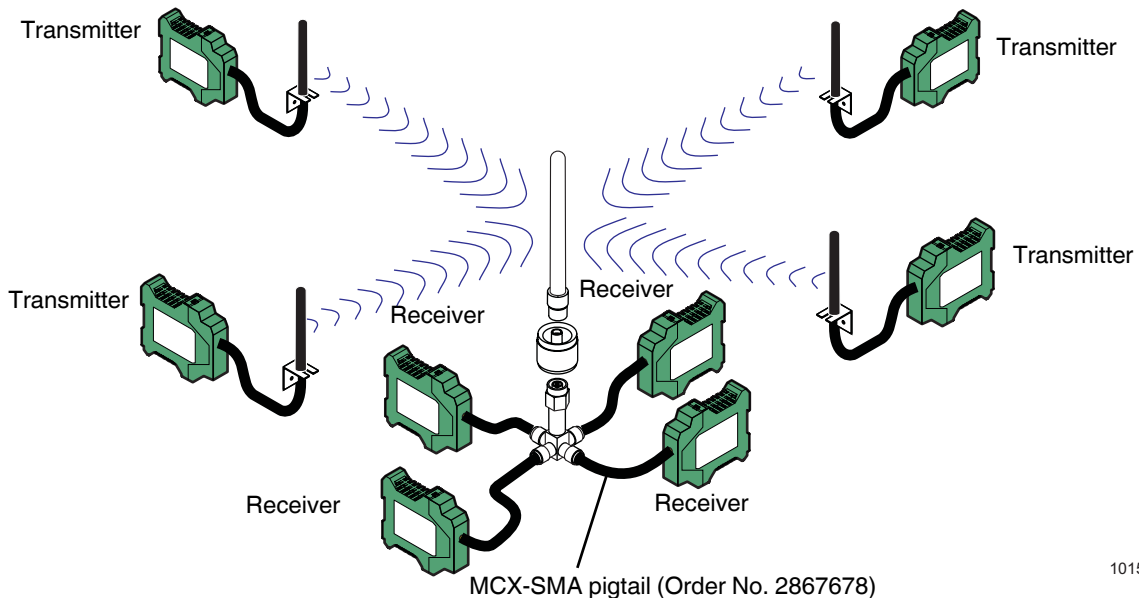

101580B003

Figure 64 Application example with four transmitters and one antenna

WIRELESS ACCESSORIES

7.3 Application examples for the RAD-ISM-2400-SPL-2-SMA 2-way antenna splitter set

Figure 65 shows a unidirectional application (point-to-multipoint) with a central station, which sends control signals to two receivers in the field.

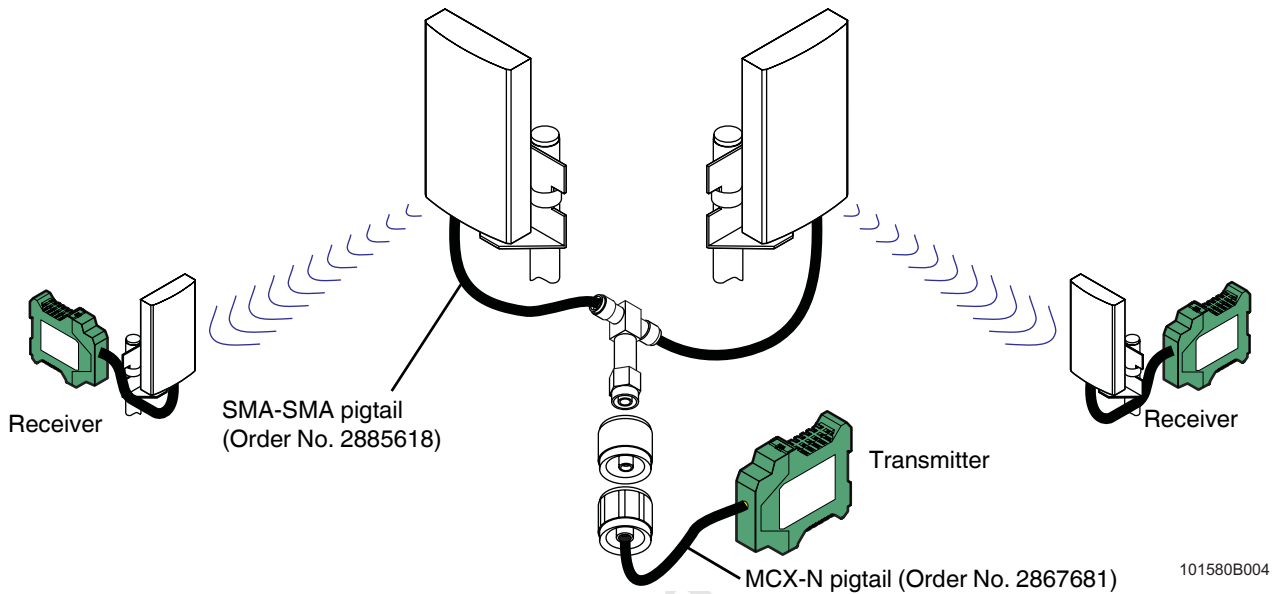

Figure 65 Application example with one transmitter and two antennas (point-to-multipoint)

i Only **one** transmitter can be connected to an antenna splitter.

Figure 66 shows a unidirectional application with two transmitters in the field and a central station with two receivers. Both receivers receive their signal information via only one antenna. In this application, an antenna is eliminated by using a 2-way antenna splitter.

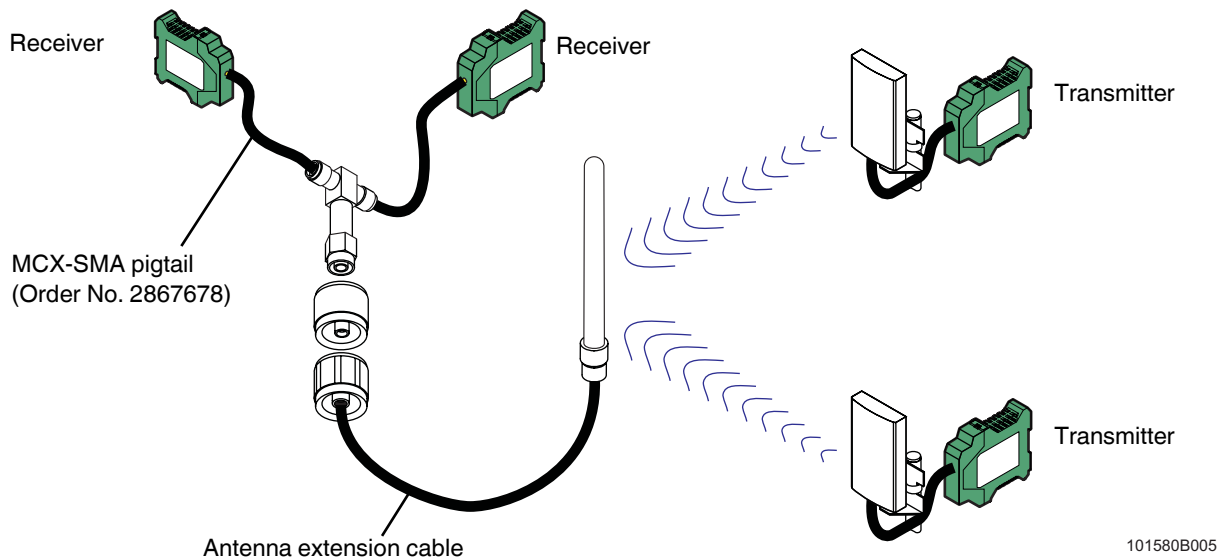

Figure 66 Application example with two transmitters and one antenna

WIRELESS ACCESSORIES

Figure 67 shows a bidirectional application with two transceivers and one repeater. Two panel antennas for transmitting and receiving can be connected to the repeater via the 2-way antenna splitter. This enables a large range and ideal antenna alignment to be achieved.

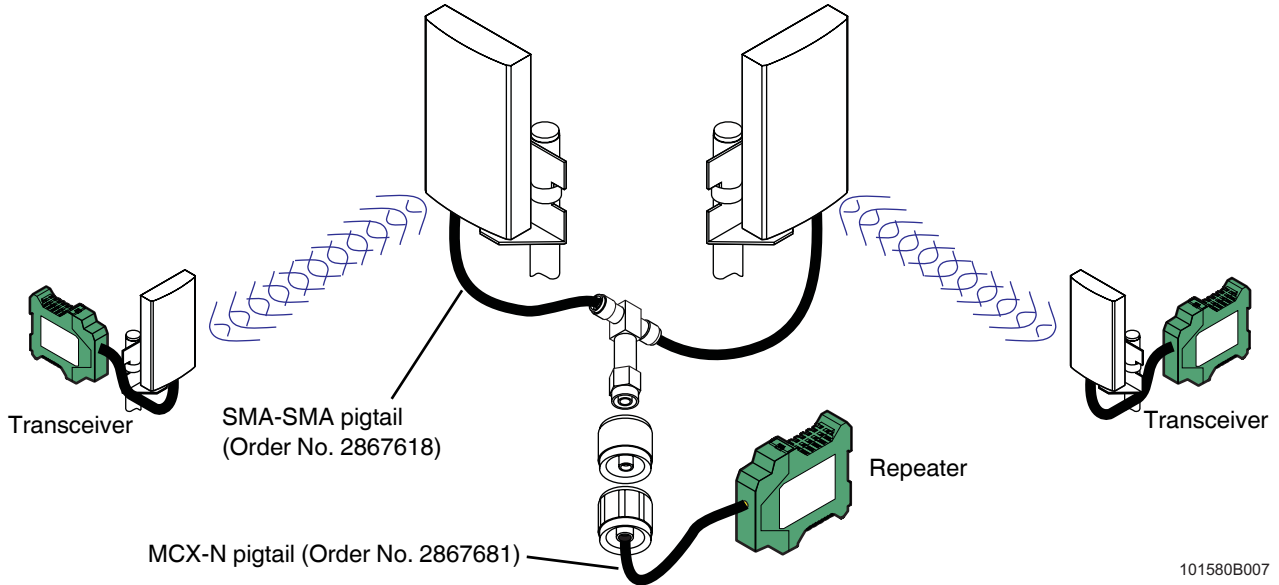

Figure 67 Application example with two transceivers and one repeater



Only **one** transceiver can be connected to an antenna splitter.

© PHOENIX CONTACT 2010-04-27