

THIS COPY IS PROVIDED ON A RESTRICTED BASIS AND IS NOT TO BE USED IN ANY WAY DETRIMENTAL TO THE INTERESTS OF PANDUIT CORP.

PANDUIT P/N	KEY	COLOR	WEIGHT	FERRULE TYPE
FJJGM5CZYL	Z	YELLOW	.29 LB/10 PCS (134.0 g/10 PCS)	ZIRCONIA (CERAMIC)

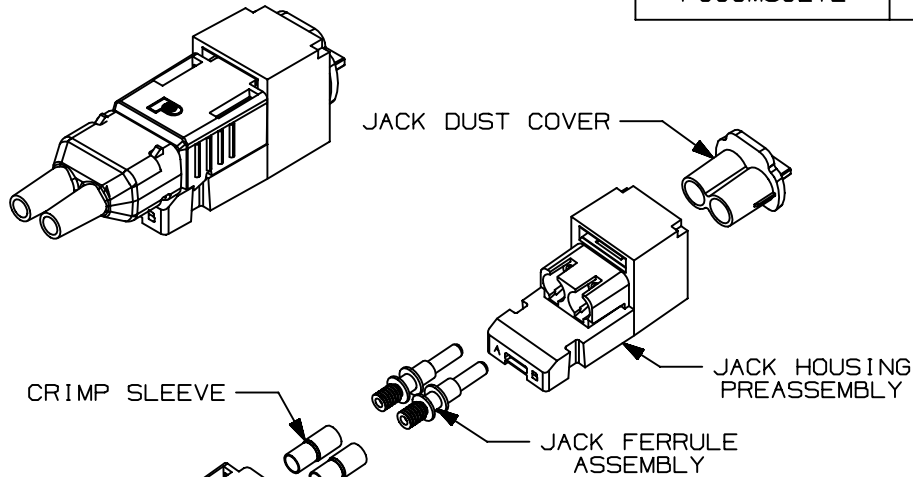

- NOTES:
- SEE CURRENT CATALOG FOR ADDITIONAL PART NUMBER SUFFIXES TO INDICATE PACKAGE QUANTITY.
  - SEE CATALOG FOR COMPLETE LIST OF PARTS APPLICABLE FOR USE WITH THIS PART.
  - DIMENSIONS IN PARENTHESES ARE IN METRIC.
  - MATERIAL;
    - BOOTS: ELASTOMER
    - JACK COVER: PC/ABS
    - CRIMP SLEEVE: BRASS
    - FERRULE: ZIRCONIA (CERAMIC)
    - JACK HOUSING: PC/ABS
    - JACK DUST CAP: ELASTOMER

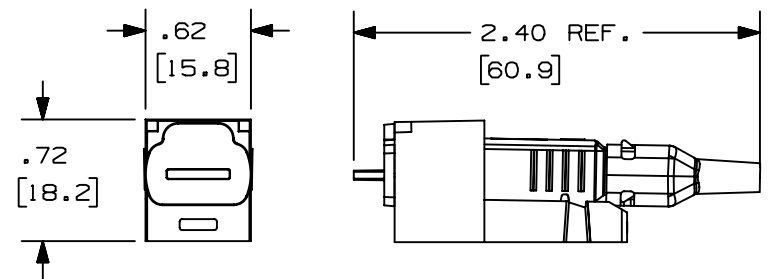
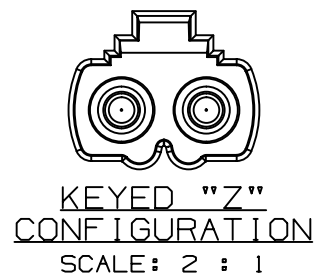
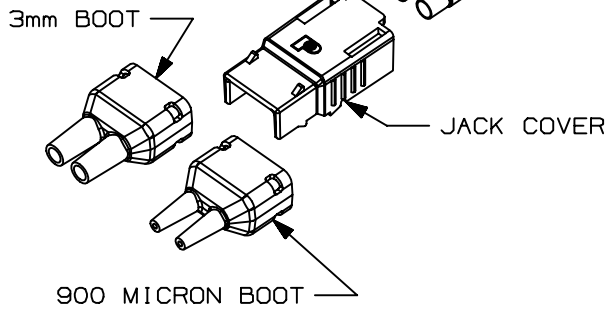

REV	DATE	BY	CHK	DESCRIPTION	ECN	R	CUST	SUP	OTH	DATE	CHK'D	REVIEW DRAWING NUMBERS	DRAWING NO.	SIZE
1	05-10-05	MYW		RELEASED TO PRODUCTION	00977-31					06-28-01	JAW	SEE NOTES	00977-31	A

OPTI-JACK FJ KEYED "Z"  
MULTIMODE MODULE  
CUSTOMER DRAWING



**PANDUIT**™  
CORP.  
TINLEY PARK, ILL 60477

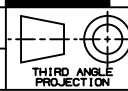

ALL DIMENSIONS ARE GIVEN IN INCHES UNLESS OTHERWISE SPECIFIED.  
DIMENSIONAL TOLERANCES ARE:  
(.X) (.XXX)±.010 (0.3)  
(.XX)±.03 (0.8) ANGLES

DRAWING FILENAME: M00977AE\_DC\_00B.prt  
SCALE: NONE  
PART NO.: FJJGM5CZYL

DRAWN BY: MC

REVIEW DRAWING NUMBERS

DRAWING NO.: 00977-31

DATE: 06-28-01  
CHK'D: JAW

SEE NOTES

SIZE: A